

June 21, 2023

Michelle Luplow
Environmental Quality Analyst
Air Quality Division
Michigan Department of Environment, Great Lakes, and Energy (EGLE), Air Quality Division (AQD)

Ms. Luplow,

Re: Brent Run Landfill GCCS Plan

In the ongoing response to the EGLE AQD Violation Notice dated 4/5/23, please find the enclosed Gas Collection and Control System Plan (GCCS) on behalf of Brent Run Landfill.

Sincerely,

Tim Church
General Manager
Brent Run Landfill, Inc.

Landfill Gas Collection and Control System Design Plan

Brent Run Landfill

JUNE 19, 2023

TETRA TECH PROJECT #209-4231207

PREPARED FOR

Brent Run Landfill, Inc.

8335 W. Vienna Road
Montrose, Michigan 48457

PREPARED BY

Tetra Tech
39395 W. Twelve Mile Road, Suite 103
Farmington Hills, MI 48331

DESIGN PLAN CERTIFICATION

The material and data in this report were prepared under the supervision and direction of the undersigned.

Khaled Mahmood

6/19/2023

Khaled Mahmood, P.E.
Certifying Engineer
MI P.E. License No. 6201048110

Date



Jakub Sowa

6/19/2023

Jakub Sowa
Project Manager – Biogas Engineering

Date

June 19, 2023

TABLE OF CONTENTS

1.0	INTRODUCTION.....	1-1
2.0	EXISTING SITE CONDITIONS.....	2-2
2.1	Landfill Description	2-2
2.2	Landfill Gas Collection and Control System	2-2
3.0	FUTURE SITE DEVELOPMENT	3-1
3.1	Landfill Development Plan	3-1
3.2	Landfill Gas Control System Expansion Capabilities.....	3-1
4.0	COMPLIANCE REVIEW AND EVALUATION.....	4-1
4.1	Compliance with §62.16728(a)(1) AND §63.1962(a)(1).....	4-1
4.1.1	Control of Surface Emissions	4-1
4.1.2	Depth of Refuse	4-1
4.1.3	Landfill Gas Generation Rates and Flow Characteristics.....	4-2
4.1.4	Landfill Cover Properties	4-2
4.1.5	Landfill Gas Control System Expandability.....	4-2
4.1.6	Leachate and Condensate Management	4-3
4.1.7	Accessibility	4-3
4.1.8	Compatibility with Refuse Filing Operations	4-3
4.1.9	Integration with Closure End Use	4-4
4.1.10	Air Intrusion Control.....	4-4
4.1.11	Corrosion Resistance	4-4
4.1.12	Fill Settlement	4-4
4.1.13	Resistance to Decomposition Heat	4-5
4.1.14	Ability to Isolate Individual Components or Sections for Repair.....	4-5
4.2	Compliance with §62.16728(a)(2) and §63.1962(a)(2)	4-5
4.3	Compliance with §62.16728(a)(3) AND §63.1962(a)(3).....	4-6
4.3.1	Asbestos and Non-degradable Materials	4-6
4.3.2	Non-productive Areas	4-7
4.4	Compliance with §62.16728(b)(1), (2), AND (3) AND §63.1962(b)(1), (2), AND (3).....	4-7
4.4.1	Landfill Gas Extraction Component Construction.....	4-7
4.4.2	Landfill Gas Extraction Component Installation.....	4-9
4.4.3	Landfill Gas Extraction Component Connections to Landfill Gas Transmission Piping	4-11
4.5	Compliance with §62.16728(c)(1) AND (2) AND §63.1962(c)(1) AND (2)	4-12
4.5.1	Existing Landfill Gas Flow Rate Data	4-12
4.5.2	Future Landfill Gas Flow Rate Estimates	4-12
4.6	Alternatives and Compliance WITH §62.16714(e)(2) and §63.1962(b)(2).....	4-12
4.6.1	Submit a Design Plan	4-13
4.6.2	Landfill Gas Generation Rates and Flow Characteristics.....	4-14
4.6.3	NSPS and NESHAP Alternative Standards and Requirements	4-15
4.6.4	Specifications for Active Collection Systems.....	4-15
4.6.5	Control Systems	4-17

June 19, 2023

5.0 LIMITATIONS 5-21

APPENDIX SECTIONS

APPENDICES

- Appendix A-1 Calculations - Gas Generation Rate Modeling
- Appendix A-2 Calculations - Radius of Influence and Well Spacing Estimates
- Appendix A-3 Calculations - Condensate Generation Estimates
- Appendix B Headloss Analysis
- Appendix C Drawings
- Appendix D Surface Emissions Monitoring Plan
- Appendix E Approved Alternatives to the NSPS and/or NESHAP
- Appendix F Reference Documents for Approved Alternatives to the NSPS and/or NESHAP

June 19, 2023

1.0 INTRODUCTION

The purpose of this document is to provide a general design plan in accordance with the design requirements of 40 CFR Part 63, Subpart AAAA, *National Emission Standards for Hazardous Air Pollutants (NESHAP) for MSW Landfills* (Subpart AAAA) and 40 CFR Part 62, Subpart OOO, *Approval and Promulgation of State Plans for Designated Facilities and Pollutants* (Subpart OOO) for the existing and future landfill gas collection and control system (GCCS) at the Brent Run Landfill (“facility” as defined by the Clean Air Act) located in Montrose, Michigan. This GCCS Design Plan is the document that will govern the operating, monitoring, and recordkeeping standards for the GCCS at the Brent Run Landfill, and supersedes all previous submittals.

The facility has a design capacity greater than 2.5 million megagrams (Mg) and in 1996 demonstrated emissions of non-methane organic compounds (NMOC) exceeding 50 mg/year, triggering the requirement to install a GCCS under 40 CFR Part 60, Subpart WWW, New Source Performance Standards (NSPS) for MSW Landfills (Subpart WWW). In 1997, a GCCS Design Plan was developed and submitted to the Michigan Department of Environment, Great Lakes, and Energy (EGLE) (at that time known as the Michigan Department of Environmental Quality (MDEQ)) in accordance with the regulatory timeline. The facility’s currently approved GCCS Design Plan is an update to this plan, submitted in 2004. Subpart WWW regulations were superseded by those of Subpart OOO on June 21, 2021. As allowable by Subpart OOO, the facility “opted-in” to the major compliance provisions of Subpart AAAA prior to the effective date of the revised rule (September 27, 2021). Due to this action, the facility maintains compliance by following the provisions of §63.1958, 63.1960, and 63.1961 of Subpart AAAA in lieu of compliance with §62.16716, 62.16720, and 62.16722 of Subpart OOO. Due to actions taken pursuant to its prior applicability under Subpart WWW, Brent Run Landfill is categorized as a “legacy-controlled” landfill under Subpart OOO.

June 19, 2023

2.0 EXISTING SITE CONDITIONS

2.1 LANDFILL DESCRIPTION

The Brent Run Landfill is located in Montrose, Michigan. The facility is owned and operated by Brent Run Landfill, Inc., a subsidiary of GFL Environmental Inc. (GFL). The landfill was owned by City Management Corporation when it originally began receiving refuse in 1993. In subsequent years, ownership was transferred to Republic in 1999, Waste Connections in 2009, and to GFL in 2021.

The facility has a design capacity of approximately 26.9 million megagrams (Mg) [31.5 million tons] of refuse. The site consists of 15 permitted cells, covering approximately 154.47 acres. Cells 1 and 2 and parts of 3, 4 and 5A, totaling approximately 30 acres, are at final grades and have final cover placement. Cells 11 through 12, approximately 88 acres, are actively being filled at the present time. Cells 13, 14 and 15 (approximately 34 acres) are unconstructed and do not contain waste. The existing cells are underlain by a composite liner system.

2.2 LANDFILL GAS COLLECTION AND CONTROL SYSTEM

At the time of this report, an active GCCS has been constructed and is operating in Cells 1 through 12 of the Brent Run Landfill. This section identifies both existing and proposed components for landfill gas (LFG) management at the Brent Run Landfill. In conjunction with this report, a phased GCCS design will be implemented in order to comply with the NSPS regulations. The proposed design consists of vertical wells and interim horizontal trenches to extract LFG from the disposal area.

The existing vertical extraction wells have a maximum well spacing ranging from 250-300 feet throughout the fill area. The proposed vertical wells located along the perimeter of the fill area shall have an average well spacing of approximately 200 feet, while interior wells shall have an average well spacing of approximately 250 feet. This spacing is more conservative than the minimum spacing guidelines and calculations provided in **Appendix A-2** of this report.

Interim horizontal collection trenches may also be utilized in areas that will not reach final grade within five years of initial waste deposition. Horizontal collection trenches allow extraction of LFG from areas that are not easily accessible by vertical wells, including active fill areas. Interim horizontal collectors may be utilized in waste older than 5 years to collect LFG once a sufficient barrier of waste (greater than 40

June 19, 2023

feet) is placed above the collector to reduce the potential for air infiltration. If utilized, interim trenches will be spaced at a frequency of not more than 250 feet horizontally and 50 feet vertically.

Although no sections of the disposal area have been designated for the construction of permanent horizontal gas collection trenches, Brent Run Landfill reserves the right to install these components should future operational concerns dictate need. Additional extraction components, including caisson wells, pin wells, etc. may also be utilized for gas control as field conditions and industry practices warrant.

Each extraction location will be fitted with an adjustable flow control well head. The wellheads will include a sampling port where LFG will be evaluated for methane, oxygen, hydrogen sulfide, carbon dioxide and balance gases (nitrogen, NMOCs, and other compounds). Each wellhead will also have a flow measurement device (pitot tube or orifice plate) and a tuning valve to adjust vacuum application and flow out of the well.

Wellheads will be connected to lateral pipes, which are in turn connected to larger, high-capacity header pipes. Permanent lateral and header pipes are installed generally below grade and are typically constructed of high-density polyethylene (HDPE) pipe. Occasionally, temporary piping may be installed either above or below ground surface to improve function of the GCCS or to restore operation in a failing area. LFG is conveyed through this pipe network of laterals and headers to the GCCS control devices.

The devices which “control” the LFG collected by the facility’s gas collection system as defined by governing federal regulations include one open flare, one enclosed flare, and LFG treatment system equipment located at an adjacent landfill gas to energy (LFGTE) facility. The LFGTE Plant is owned and operated by a third-party, and is contracted to receive LFG generated from the landfill as fuel. The LFGTE facility controls the LFG via a treatment system pursuant to §62.16714(c)(3) and §63.1959(b)(2)(iii)(C). Downstream of the treatment system, five internal combustion engines (four Caterpillar G3520C model engines and one Caterpillar 3512 model engine) combust LFG to generate electricity for sale. The LFGTE treatment system serves as the primary control device for LFG collected by the landfill, while the two flares, which are owned by the landfill, serve as backup control devices in the event the LFGTE Plant cannot control the full capacity of the LFG collected or is down for maintenance. Treated LFG which cannot be utilized by the LFGTE is combusted in the backup flares per regulatory requirements. GCCS components subject to the provisions of governing federal regulations are identified in the process flow diagram displayed in **Figure 2-1**. Additional information on the LFG control system can be found in **Section 4.6.5** of this document.

June 19, 2023

Figure 2-1: GCCS Process Flow Diagram

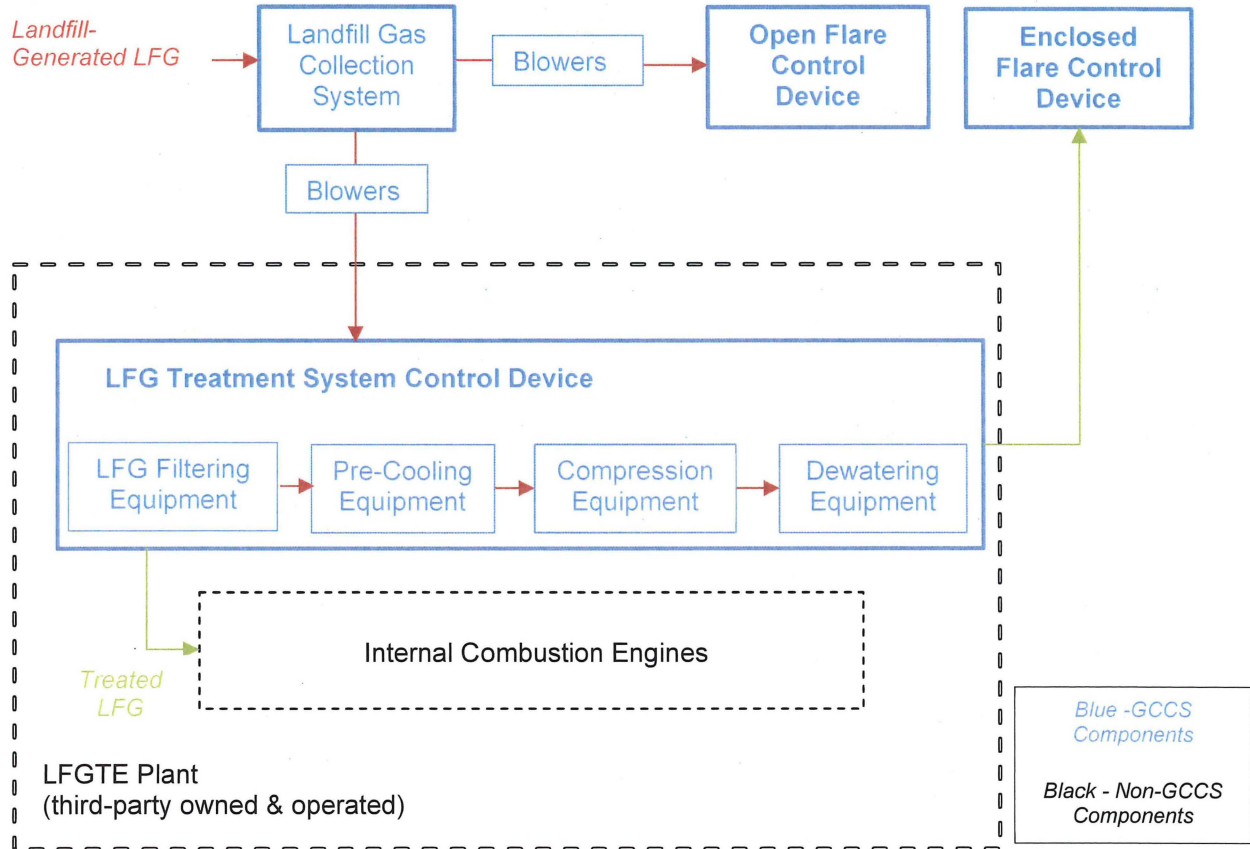

Condensate (liquid that forms in the GCCS piping as LFG cools) is discharged to the landfill’s leachate collection system (LCS). Condensate is removed from the GCCS piping via through dripleg drains with direct connections to LCS cleanout/access risers or to condensate pump stations located around the perimeter of the disposal area. Condensate drained by gravity to the condensate pump stations is discharged via force main(s) to leachate collection and storage locations on the site, and ultimately combined with leachate for disposal. Condensate collected in drains will be transported via gravity directly to the leachate collection system via leachate system access risers. The condensate will be disposed of coincidentally with landfill leachate in accordance with the requirements of the facility’s applicable permits.

Additional information and drawings of the GCCS are included in **Appendix C**.

June 19, 2023

3.0 FUTURE SITE DEVELOPMENT

3.1 LANDFILL DEVELOPMENT PLAN

The Brent Run Landfill will continue waste filling operations in accordance with the facility Operating License and its internal fill progression plans. Installation of GCCS components is anticipated to be coordinated with fill development and as otherwise required by NSPS regulations regarding installation of GCCS components stipulated in §62.16714(b)(2)(ii) and §63.1959(b)(2)(ii). Due to operational changes, the GCCS design presented in **Appendix C** may be altered to maintain compliance with the provisions of the NSPS or NESHAP and to accommodate actual field conditions at the time of construction.

3.2 LANDFILL GAS CONTROL SYSTEM EXPANSION CAPABILITIES

The GCCS is designed to be expanded as fill operations proceed to reach final grade or to install interim systems. Vertical wells will typically be installed in areas that have reached final grade. Vertical wells and/or interim horizontal collection trenches may be installed as an interim control measure in disposal areas that have been in place for more than five years, but that are not yet at final waste grades.

Vertical extraction wells installed prior to reaching final grade will either be extended to the final grade level or abandoned and replaced to maximize LFG collection. This determination will be made based upon the physical condition of the wells, their ability to provide effective LFG extraction, and field conditions at the time of final cap installation.

Proposed LFG headers are sized to accommodate the maximum calculated LFG generation rate of 4,166 scfm (refer to **Section 4.5.2**) and are designed with flanged connections for expansion as new collectors are installed, in accordance with NSPS requirements. Additionally, the use of HDPE header piping provides for flexible and efficient connections for future expansion of the header piping system.

Additional information and drawings of the GCCS are included in **Appendix C**.

June 19, 2023

4.0 COMPLIANCE REVIEW AND EVALUATION

The purpose of this section is to describe and document information required to certify compliance of the GCCS with the applicable sections of Federal Plan Subpart 000 and NESHAP Subpart AAAAA.

4.1 Compliance with §62.16728(a)(1) AND §63.1962(a)(1)

§62.16728(a)(1) and §63.1962(a)(1) The collection devices within the interior must be certified to achieve comprehensive control of surface gas emissions by a professional engineer. The following issues must be addressed in the design: depths of refuse, refuse gas generation rates and flow characteristics, cover properties, gas system expandability, leachate and condensate management, accessibility, compatibility with filling operations, integration with closure end use, air intrusion control, corrosion resistance, fill settlement, resistance to the refuse decomposition heat and ability to isolate individual components or sections for repair or troubleshooting without shutting down entire collection system.

This GCCS has been designed to be consistent with NSPS requirements to achieve comprehensive control of both lateral migration and surface emissions of LFG. Issues related to compliance with §62.16728(a)(1) and §63.1962(a)(1) are discussed in the following sections.

Applicable information used in the design of the GCCS is included in **Appendices A (Calculations), Appendix B (Head Loss Analyses), Appendix C (GCCS Design Plans), Appendix D (Surface Emissions Monitoring Plan) and Appendices E-F (Approved Alternatives to the NSPS).**

4.1.1 Control of Surface Emissions

The GCCS was designed to minimize both subsurface lateral migration and surface emissions of LFG from the landfill. System performance depends upon the installation of a satisfactory GCCS system, its proper management, and maintenance of a final cover system. If there is a temporary exceedance in surface methane emissions it will be addressed by appropriate response, evaluating both the GCCS and final cover systems. Appropriate action will then be taken to correct the exceedance, as required by governing federal regulations.

4.1.2 Depth of Refuse

Depths of refuse will be calculated prior to installation of vertical LFG extraction wells based upon existing topography, final grade and liner grade permit plans, and record documentation of landfill liner grades.

June 19, 2023

4.1.3 Landfill Gas Generation Rates and Flow Characteristics

In compliance with §60.752(b)(2)(ii)(A), the maximum expected LFG flow rate for the site was used for sizing the GCCS. The LFG generation rate calculations were performed using the United States Environmental Protection Agency (USEPA) Landfill Gas Emission Model (LandGEM) V3.03 (AP-42 default values $k = 0.04/\text{year}$ and $L_0 = 100 \text{ m}^3/\text{Mg}$), historical waste receipts, the permitted design capacity of the facility, and current operating parameters were utilized to develop the LFG generation rate calculations.

The maximum LFG generation rate of approximately 4,166 scfm is projected to occur in 2054.

The proposed GCCS components to be installed shall be sized to accommodate the maximum LFG generation rate of 4,166 scfm to ensure adequate future capacity. As discussed in **Section 3.2** of this Design Plan, the GCCS is designed in a manner to allow expansion of the wellfield, piping, and LFG control device capacity.

The LandGEM emissions model is a “design tool,” which uses the information available to project future operating conditions. This model was developed based upon operating conditions at a cross-section of landfills within the United States and is approved for use by the USEPA. The most up to date information pertaining to the site operating parameters was utilized for this GCCS Design Plan. Actual operating parameters may change in the future and may require changes in the system flow characteristics and process equipment as the system is developed. These changes will be made in accordance with governing federal regulations, including §62.16714.

LFG generation projections are provided in **Appendix A-1**.

4.1.4 Landfill Cover Properties

The final cover design, for areas without an existing final cover system, will incorporate a composite geosynthetic/low permeability soil barrier. The primary purpose of the final cover system is to preclude infiltration of precipitation that would generate additional leachate. However, the final cover system design also provides a significant barrier to LFG emission and air infiltration when combined with an active LFG extraction system. The GCCS components will provide for collection of LFG, relieving pressures from LFG buildup from beneath this layer.

4.1.5 Landfill Gas Control System Expandability

June 19, 2023

Expandability of the GCCS is achieved by installing expansion points, such as tees with blind flanges, as access points to extend the GCCS. These expansion points provide planned access for expansion of the LFG transmission piping and LFG control device facility(s) in the future. Similarly, additional LFG control devices shall be added to expand the extraction capabilities of the GCCS. These flanges or expansion points provide planned access for expansion of the LFG transmission piping and LFG control device facility(s) in the future. In the event that actual LFG flow rates do exceed the capacity of the system additional GCCS components will be designed and installed in accordance with NSPS requirements, to supplement the original design.

4.1.6 Leachate and Condensate Management

Leachate management is accomplished using an engineered leachate collection and handling system (LCS). Leachate is collected in the LCS of each landfill cell, then is pumped through forcemain pipes to the permitted discharge point for the off-site disposal and treatment at the local Publicly Owned Treatment Works (POTW) waste water facility. The LCS is designed according to Subtitle D standards (40 CFR §257 and §258) and is part of the Solid Waste Disposal Area License.

LFG piping grades will be maximized where practical to reduce the impact of differential settlement and promote positive condensate drainage. The proposed transmission header and lateral piping will be sloped at a minimum of three percent (3%) within waste limits (0.5 percent outside waste limits), unless otherwise denoted, to promote condensate to flow by gravity to engineered low points in the GCCS piping, and subsequent collection of the condensate. Condensate collected at the engineered low points will be handled by pump stations or gravity drains that will discharge directly into the LCS or other leachate or condensate collection and control structures.

4.1.7 Accessibility

Accessibility to the GCCS components is achieved by installing commonly accessed components (such as wellheads and monitoring ports) on relatively flat surfaces of the landfill or near the facility's Road network. Wellheads, piping risers, valves and monitoring ports of the proposed system will be installed above grade and raised as needed to maintain accessibility.

4.1.8 Compatibility with Refuse Filing Operations

At the time of this report, an active GCCS has been constructed and is operating in Cells 1 through 12 of the Brent Run Landfill. The proposed GCCS has been designed to integrate the existing GCCS components currently operating at the Brent Run Landfill. All construction is phased so existing collection can remain operational with minimal, localized interruptions.

June 19, 2023

As refuse filling operations proceed and portions of the site reach final or near-final grades, additional GCCS components will be installed. This method of installation allows GCCS components to be constructed in accordance with §62.16728(a)(1) and §63.1962(a)(1) while minimizing interference of the GCCS with ongoing filling operations.

4.1.9 Integration with Closure End Use

Currently, the post-closure end-use for the site is unspecified and will likely be utilized as open space. Any modifications to the closure end-use must be approved by facility personnel to evaluate the compatibility with the GCCS. Any items of concern related to maintaining and operating the GCCS will be mitigated by either altering the proposed post-closure end-use or by adjusting or modifying the GCCS in accordance with NSPS or NESHAP requirements.

4.1.10 Air Intrusion Control

Oxygen from air intrusion can cause subsurface reactions or reduce the heat content of the LFG. Air intrusion is minimized by using soil backfill in the upper zone of the vertical wells and above the horizontal collectors to seal pathways to the extraction zone. Where extraction wells are placed in final cover areas through a geosynthetic component, the penetration is sealed. To accommodate the penetration of the geomembrane component of the final cover system, in areas with a geosynthetic cap, the geomembrane component will be typically fitted to the pipe penetrations utilizing a "pipe boot". Potential air intrusion and LFG emissions through the cover system will be controlled through periodic monitoring and adjustment of the GCCS, in coordination with appropriate maintenance of the landfill cover system.

4.1.11 Corrosion Resistance

Corrosion resistance of the GCCS is achieved using corrosion resistant materials or materials that have a corrosion resistant coating, in accordance with §62.16728(b)(1) and §63.1962 (b)(1). The primary components used in the construction of the GCCS are HDPE and polyvinyl chloride (PVC). Components will be inspected during routine GCCS monitoring for abrasion, chipping, or other potential deterioration of the components. If damage to the materials is observed that may be detrimental to the performance of the GCCS, the components will be replaced or repaired.

4.1.12 Fill Settlement

Settlement will occur due to overburden and decomposition of the refuse. The settlement of the waste can impact gas extraction wells, pulling them down, causing tipping or tilting, and deflecting the subgrade riser sections. To accommodate refuse settlement, the GCCS components were designed and are to be installed with several features to account for this settlement, including:

June 19, 2023

- LFG extraction well heads are connected to the LFG transmission piping by an above-ground flexible pipe or hose connection. This allows the LFG piping to accommodate some changes in the orientation of the LFG transmission piping or LFG extraction well while maintaining this connection.
- LFG transmission piping will be sloped at sufficient grades (see **Section 4.1.6**) so that reasonable amounts of differential and total settlement may occur without causing pipe breakage or disrupting the overall flow gradient of the LFG transmission piping.
- HDPE piping will be used for the construction of the header piping and transmission system. HDPE piping is flexible and absorbs differential settlement without breaking or cracking.

4.1.13 Resistance to Decomposition Heat

Resistance of the GCCS to the heat generated from refuse decomposition is achieved through materials tested and proven to withstand temperatures well above those typically found in landfills.

Waste and gas temperatures are monitored during construction and operation of the wellfield.

Temperatures showing an increasing trend or sudden increase will be investigated and addressed. The GCCS will be inspected during routine LFG system monitoring for heat damage. If heat damage of the GCCS components is observed and is believed to be detrimental to the operation of the GCCS, the cause of the elevated landfill temperature will be investigated and the GCCS will be adjusted or modified to mitigate the effects of the elevated temperatures.

4.1.14 Ability to Isolate Individual Components or Sections for Repair

The GCCS has been designed with isolation valves at various points throughout the GCCS. These valves allow for specific portions of the GCCS to be closed off for repair without shutting down the entire GCCS.

These valves are frequently inspected to ensure they are properly functioning and are not damaged.

4.2 COMPLIANCE WITH §62.16728(a)(2) AND §63.1962(a)(2)

§62.16728(a)(2) and §63.1962(a)(2) The sufficient density of gas collection devices determined in paragraph (a)(1) of this section must address landfill gas migration issues and augmentation of the collection system through the use of active or passive systems at the landfill perimeter or exterior.

Per the definitions given in §62.16730 and §63.1990, “sufficient density” means “any number, spacing, and combination of collection system components. . . necessary to maintain emission and migration

June 19, 2023

control as determined by measures of performance set forth in this part.” LFG well spacing was established using the method described in the book “*Methane Generation and Recovery from Landfills*, EMCON, 1982.” The values developed by this method were compared to those developed by the equation from the *NSPS Background Information Document*, 1991 with a more conservative EMCON value utilized for design purposes. This is consistent with spacing criteria used at other landfills and should effectively control surface emissions and subsurface migration of LFG in accordance with NSPS requirements.

Additionally, the spacing of vertical and interim horizontal extraction wells is within the guidelines defined in *Table 5-1, Summary of Suggested Collector Density, Training Course for Landfill Gas NSPS/EG Regulatory Personnel to Review GCCS Design Submittals*, North Carolina State University, September 1998. This guidance recommends a horizontal collector spacing of 30 feet to 50 feet vertically and 150 feet to 300 feet horizontally for interim horizontal extraction wells, and a vertical well spacing of 250 feet to 300 feet in post-Subtitle D landfills with wet waste.

Brent Run Landfill conducts quarterly surface emissions monitoring in accordance with applicable federal requirements. If the GCCS at the facility does not meet the measures of performance set forth, the GCCS will be adjusted or modified in accordance with the applicable federal requirements. These adjustments or modifications may include the installation of additional collection elements, cap repairs or other actions defined by field conditions at the time of monitoring.

4.3 COMPLIANCE WITH §62.16728(a)(3) AND §63.1962(a)(3)

§62.16728(a)(3) and §63.1962(a)(3) The placement of gas collection devices determined in paragraph (a)(1) of this section must control all gas producing areas, except as provided by paragraphs (a)(3)(i) and (ii) of this section.

Issues related to compliance with §62.16728(a)(3) and §63.1962(a)(3) are discussed in the following sections.

4.3.1 Asbestos and Non-degradable Materials

§62.16728(a)(3)(i) and §63.1962(a)(3)(i) Any segregated area of asbestos or nondegradable material may be excluded from collection if documented as provided under §62.16726(d) [of Subpart OOO, or §63.1983(d) of Subpart AAAA]. The documentation must provide the nature, date of deposition, location and amount of asbestos or

June 19, 2023

nondegradable material deposited in the area, and must be provided to the Administrator upon request.

No areas have been excluded from the coverage of the GCCS as a result of the placement of asbestos or other nondegradable materials.

4.3.2 Non-productive Areas

§62.16728(a)(3)(ii) and §63.1962(a)(3)(ii) Any nonproductive area of the landfill may be excluded from control, provided that the total of all excluded areas can be shown to contribute less than 1 percent of the total amount of NMOC emissions from the landfill. The amount, location, and age of the material must be documented and provided to the Administrator upon request. A separate NMOC emissions estimate shall be made for each section proposed for exclusion, and the sum of all such sections shall be compared to the NMOC emissions estimate for the entire landfill.

At the time of the design of the GCCS, no areas of the landfill were determined to be non-productive. No areas of the landfill have been excluded from the coverage of the GCCS on this basis.

4.4 COMPLIANCE WITH §62.16728(b)(1), (2), AND (3) AND §63.1962(b)(1), (2), AND (3)

§62.16728(b) and §63.1962 (b) Each owner or operator seeking to comply with §62.16714(b) [§63.1959(b)(2)(ii) for Subpart AAAA] must construct the gas collection devices using the following equipment or procedures:

4.4.1 Landfill Gas Extraction Component Construction

§62.16728(b)(1) and §63.1962 (b)(1) The landfill gas extraction components must be constructed of polyvinyl chloride (PVC), high density polyethylene (HDPE) pipe, fiberglass, stainless steel, or other nonporous corrosion resistant material of suitable dimensions to: convey projected amounts of gases; withstand installation, static, and settlement forces; and withstand planned overburden or traffic loads. The collection system must extend as necessary to comply with emission and migration standards. Collection devices such as wells and horizontal collectors must be perforated to allow gas entry without head loss sufficient to impair performance across the intended extent of control. Perforations must be situated with regard to the need to prevent excessive air infiltration.

June 19, 2023

Issues related to compliance with §62.16728(b)(1) and §63.1962(b)(1) are discussed in the following sections.

4.4.1.1 Materials

The GCCS components will generally be constructed of polyvinyl chloride (PVC) or high-density polyethylene (HDPE). Some components of the collection assemblies or fittings may be constructed of, fiberglass, corrosion-resistant steel, Neoprene (gaskets and seals) and other non-porous corrosion resistant materials.

4.4.1.2 Component Sizing

The GCCS components proposed to be installed in the Facility are sized for a maximum LFG flow rate of 4,166 scfm (see **Section 4.1.3**). This accounts for the entire MSW disposal capacity, at the final grade development elevations of the landfill.

The capacity of the current control devices (LFGTE plant and flares) is approximately 5,500 scfm. Capacity of the extraction and treatment system components will be phased in as waste placement progresses, and system generation and extraction rates increase. If LFG flow rates exceed the capacity of the control devices, additional control device capacity will be designed and installed in accordance with NSPS or NESHAP requirements.

4.4.1.3 Component Loading

The proposed GCCS components within the Facility are consistent with those installed at other landfills that have been in place for extended periods of time (in excess of 15 years) and verified to withstand installation, static, settlement, overburden, and traffic loads. The materials used for the GCCS construction are industry-standard materials that are proven to withstand typical loads within a landfill environment, and static loads such as overburden and traffic loads for the LFG transmission piping are calculated to be less than the allowable loads recommended by the piping manufacturer. In the event damage to GCCS components are identified, the GCCS will be adjusted or modified in accordance with NSPS or NESHAP requirements.

Typically, GCCS components requiring footings or foundations will be placed outside the waste area. Foundations supporting the GCCS components will include consideration for active and passive loading as well as any mechanical loads, and will be designed for the local soil conditions, and tolerances of the equipment. Within the landfill, settlement forces cannot accurately be predicted due to the non-homogeneous nature of the refuse within the landfill. Road crossings will be designed to protect the

June 19, 2023

GCCS piping using casings or mitigated by burial depth. Traffic loading in active areas is less controllable, but will be mitigated by burial depth.

4.4.1.4 System Expansion

The GCCS shall be expanded as necessary to comply with NSPS requirements. The Brent Run Landfill will conduct monitoring and document compliance of the GCCS, in accordance with NSPS or NESHAP requirements. If the GCCS at the Brent Run Landfill does not meet the measures of performance set forth in these regulations, the GCCS will be adjusted or modified in accordance with NSPS or NESHAP requirements.

4.4.1.5 Component Perforation

The vertical well and horizontal collection piping will be perforated as shown on the design plan drawings (**Appendix C**), to allow LFG entry without inducing head losses sufficient to impair performance across the intended extent of control. The perforation patterns used for the Brent Run Landfill GCCS design have been successfully used in previous LFG control applications.

4.4.1.6 Air Infiltration

The LFG collection elements were designed to prevent excessive air infiltration through the use of solid pipe and soil backfill near the ground surface for vertical LFG extraction wells and interim/supplemental horizontal collection trenches. Hydrated bentonite plugs and geomembrane seals, if warranted, will be provided around vertical well casings and interim/supplemental horizontal collection trench access piping, where they penetrate the landfill final cover or interim cover systems. Further, air intrusion control will be accomplished through the operational monitoring standards for the LFG collection elements in accordance with NSPS requirements. If the GCCS does not meet the operational monitoring standards, it will be adjusted or modified in accordance with NSPS or NESHAP requirements.

4.4.2 Landfill Gas Extraction Component Installation

§62.16728(b)(2) and §63.1962 (b)(2) Vertical wells must be placed so as not to endanger underlying liners and must address the occurrence of water within the landfill. Holes and trenches constructed for piped wells and horizontal collectors must be of sufficient cross-section so as to allow for their proper construction and completion including, for example, centering of pipes and placement of gravel backfill. Collection devices must be designed so as not to allow indirect short circuiting of air into the cover or refuse into the collection system or gas into the air. Any gravel used around pipe perforations should be of a dimension so as not to penetrate or block perforations.

June 19, 2023

Issues related to compliance with §62.16728(b)(2) and §63.1962 (b)(2) are discussed in the following sections.

4.4.2.1 Component Placement

Future depths of refuse were calculated, at the time of the design of the GCCS, based upon the permit plan final grades and landfill liner grades. Vertical LFG extraction wells will be designed to extend from the landfill surface to within no less than fifteen (15) feet of the landfill base, unless otherwise designed for specific site considerations.

4.4.2.2 Leachate

The occurrence of leachate within the landfill will be addressed by the LCS as stated in **Section 4.1.6** of this Design Plan. Leachate management within the portions of the landfill with a composite liner will be accomplished through the LCS which includes a leachate drainage layer, collection piping, side slope risers with liquid pumping equipment, and liquid disposal systems.

For these reasons, it is not expected that free liquids will be frequently encountered during the drilling of the vertical LFG extraction wells. If free liquids are encountered, the drilling contractor will attempt to drill through the perched zone of liquids allowing drainage into the underlying waste mass and the LCS. If the zone of perched liquids cannot be penetrated, the well installation may be terminated. If necessary, appropriate measures will be taken to complete the well installation procedure at a nearby location.

If perched liquids are observed within the extraction wells after installation, and it is determined that the liquid level is restrictive to efficient LFG extraction, the leachate level will be reduced. This is typically accomplished by periodic pumping of the liquids using either electric or pneumatic pumping systems. Liquids removed from the well casings will be discharged to the LCS or other leachate management infrastructure.

4.4.2.3 Wells and Trenches

Vertical wells and interim/supplemental horizontal collection trenches, constructed for LFG collection elements, will be of sufficient cross-section to allow for their proper construction and completion, including centering of the pipes and placement of suitable backfill. The wells and interim/supplemental horizontal collection trenches will be constructed under supervision of a construction quality assurance program implemented by Brent Run Landfill and verified to be properly constructed, as indicated on the design plans in **Appendix C**.

4.4.2.4 Component Short Circuiting

June 19, 2023

To avoid short-circuiting, or self-damage, the LFG collection elements are designed to prevent air infiltration through the cover, refuse contamination of the collection elements, and direct venting of LFG to the atmosphere. Air intrusion control will be verified through monitoring of gas quality at the extraction components, monitoring of surface emission levels and maintenance of the landfill cover in accordance with NSPS or NESHAP requirements. Separation of the collection elements from the refuse is accomplished by placing gravel backfill in the annular borehole space around extraction wells casings and gravel backfill or other suitable materials for the interim/supplemental horizontal collection trench pipes, providing a filter pack between the refuse and the LFG collection elements. Direct venting of the LFG to the atmosphere is avoided by operating the GCCS under a controlled application of vacuum and the quarterly monitoring of surface emissions (see **Section 4.2**).

4.4.2.5 Backfill

Gravel or other suitable backfill material of sufficient size is specified to prevent penetration or blockages of the LFG collector pipe perforations. Gravel (non-calcareous) to be utilized in vertical wells and horizontal collector trenches will be a nominal 1-inch to 3-inch particle size, as indicated on the design plans. Other suitable material, such as tire chips, may be utilized in interim/supplemental horizontal collection trenches.

4.4.3 Landfill Gas Extraction Component Connections to Landfill Gas Transmission Piping

§62.16728(b)(3) and §63.1962 (b)(3) Collection devices may be connected to the collection header pipes below or above the landfill surface. The connector assembly must include a positive closing throttle valve, any necessary seals and couplings, access couplings and at least one sampling port. The collection devices must be constructed of PVC, HDPE, fiberglass, stainless steel, or other non-porous material of suitable thickness.

The collection devices are connected to the collection header pipes using lateral piping. The lateral piping is connected to the header piping either above or below the landfill surface, as required by field conditions at the time of installation. The connector assemblies (wellheads) will be located above grade. These assemblies include a positive closing throttle valve, necessary seals and couplings, access ports and couplings, and a minimum of one sampling port. The collection devices will be constructed of PVC, HDPE, fiberglass, corrosion-resistant steel, and other non-porous materials of suitable thickness. The GCCS components are designed to withstand anticipated installation, static, settlement, overburden, and traffic loads.

June 19, 2023

4.5 COMPLIANCE WITH §62.16728(c)(1) AND (2) AND §63.1962(c)(1) AND (2)

§62.16728(c) and §63.1962(c) Each owner or operator seeking to comply with §62.16714(c) [of Subpart OOO, or §63.1959(b)(2)(iii) of Subpart AAAA] must convey the landfill gas to a control system in compliance with §62.16714(c) [of Subpart OOO, or §63.1959(b)(2)(iii) of Subpart AAAA] through the collection header pipe(s). The gas mover equipment must be sized to handle the maximum gas generation flow rate expected over the intended use period of the gas moving equipment using the following procedures:

Issues related to compliance with §62.16728(c) and §63.1962(c) are discussed in the following sections.

4.5.1 Existing Landfill Gas Flow Rate Data

§62.16728(c)(1) and §63.1962(c)(1) For existing collection systems, the flow data must be used to project the maximum flow rate. If no flow data exists, the procedures in paragraph (c)(2) of this section shall be used.

The current total LFG extraction rate is approximately 2,200 scfm. The current extraction rate is influenced by the percentage of waste covered by an active GCCS and the extent of final cover installation, which affects the collection efficiency. The current extraction rate is generally consistent with LandGEM projections.

4.5.2 Future Landfill Gas Flow Rate Estimates

§62.16728(c)(2) and §63.1962(c)(2) For new collection systems, the maximum flow rate must be in accordance with §62.16720(a)(1) [of Subpart OOO, or §63.1960(a)(1) of Subpart AAAA].

A value of 4,166 scfm was determined to be the maximum LFG generation rate at final fill conditions, as estimated by LandGEM (see **Appendix A-1**). Assuming a maximum extraction efficiency of approximately 75% at the closure of this facility, a maximum expected recovery rate of 3,125 scfm is anticipated. However, to provide adequate capacity in the development of the GCCS design plan, a design capacity of 4,166 scfm (100% of the maximum calculated generation rate) was used, as discussed in **Section 4.4.1.2**.

4.6 ALTERNATIVES AND COMPLIANCE WITH §62.16714(e)(2) AND §63.1962(b)(2)

June 19, 2023

§62.16714(e)(2) *If the calculated NMOC emission rate, upon initial calculation or annual recalculation required in paragraph(e)(1)(ii) of this section, is equal to or greater than 34 megagrams per year, the owner or operator must.... [Install a gas collection and control system meeting the requirements in paragraphs (b)(1) through (3) and (c) of this section and (c) of this section]*

§63.1959(b)(2)(ii) *Install and startup a collection and control system that captures the gas generated within the landfill as required by paragraphs(b)(2)(ii)(B) or (C) and (b)(2)(iii) of this section within 30 months after:(A) The first annual report in which the NMOC emission rate equals or exceeds 50 Mg/yr, unless Tier 2 or Tier 3 sampling demonstrates that the NMOC emission rate is less than 50 Mg*

In 1996, the original owner of Brent Run Landfill submitted a Tier 1 non-methane organic compound (NMOC) emission rate estimate that exceeded the 50 megagrams per year (Mg/year) limit, thus subjecting the landfill to section §60.752(b)(2) of the NSPS. Subsequent Tier 2 or Tier 3 testing was not performed at this time. When Tier 2 and Tier 3 testing was performed after landfill ownership was transferred in 1999, the more accurate estimations indicated the Brent Run Landfill did not currently exceed the maximum NMOC emission rate of 50 Mg/yr threshold. On May 10, 2001, the landfill submitted an NSPS applicability determination request to the Michigan Department of Environmental Quality (MDEQ) requesting acceptance of the Tier 2 and Tier 3 results. A similar request was submitted to the USEPA Region 5 on December 10, 2001. However, the USEPA concluded that the test results could not be accepted beyond the NSPS final compliance deadline of December 10, 1998. Therefore, Brent Run Landfill is required to comply with section §60.752(b)(2) of the NSPS.

4.6.1 Submit a Design Plan

§62.16714(e)(2) Submit a collection and control system design plan prepared by a professional engineer to the Administrator within 1 year

The facility has a design capacity greater than 2.5 million Mg and in 1996 demonstrated emissions of NMOC exceeding 50 mg/year, triggering the requirement to install a GCCS under Subpart WWW. In 1997, a GCCS Design Plan was developed and submitted to the MDEQ in accordance with the regulatory timeline. The facility's currently approved GCCS Design Plan is an update to this plan, submitted in 2004.

Brent Run Landfill is defined as a "legacy controlled" landfill per §62.16730, as the facility had both submitted a collection and control system design plan prior to May 21st, 2021, in compliance with

June 19, 2023

§60.752(b)(2)(i) and had completed construction and began operations of the GCCS according to §60.752(b)(2)(ii). For legacy-controlled landfills, §62.16711(h) specifies:

When an MSW landfill subject to this subpart is a legacy controlled landfill, as defined in §62.16730, the owner or operator is not subject to the following reports of this subpart, provided the owner or operator submitted these reports under 40 CFR part 60, subpart WWW... (3) Collection and control system design plan.

Therefore, the Brent Run Landfill is not subject to §62.16714(e)(2).

§63.1959(b)(2)(i) *Submit a collection and control system design plan prepared by a professional engineer to the Administrator within 1 year as specified in §63.1981(d) or calculate NMOC emissions using the next higher tier in paragraph (a) of this section. The collection and control system must meet the requirements in paragraphs (b)(2)(ii) and (iii) of this section.*

§63.1981 states that if a facility has previously submitted a[n]... initial or revised collection and control system design plan ... under 40 CFR part 60, subpart WWW ... then that submission constitutes compliance with the initial collection and control system design plan in paragraph (d) of this section, and that resubmittal is not required. Therefore, the Brent Run Landfill is not subject to §63.1959(b)(2)(i).

4.6.2 Landfill Gas Generation Rates and Flow Characteristics

In compliance with §63.1959(b)(2)(ii)(C)(1) and §62.16714(b)(2), the maximum expected LFG flow rate for the site was used for sizing the GCCS. The LFG generation rate calculations were performed using the United States Environmental Protection Agency (USEPA) Landfill Gas Emission Model (LandGEM) V3.03 (AP-42 default values $k = 0.04/\text{year}$ and $L_0 = 100 \text{ m}^3/\text{Mg}$), historical waste receipts and the permitted design capacity of the facility.

The maximum LFG generation rate of approximately 4,166 scfm is projected to occur in 2054. LFG generation projections are provided in **Appendix A-1**.

The proposed GCCS components to be installed shall be sized to accommodate an LFG flow rate of 4,166 scfm. As discussed in **Section 3.2** of this Design Plan, the GCCS is designed to allow expansion of the wellfield, piping, and LFG control device capacity.

The LandGEM emissions model is a “design tool,” which uses the information available to project future operating conditions. This model was developed based upon operating conditions at a cross-section of

June 19, 2023

landfills within the United States and is approved for use by the USEPA. Actual operating parameters may dictate changes in the system flow characteristics and process equipment as the system is developed. These changes will be made in accordance with These changes will be made in accordance with governing federal regulations, including §62.16714.

4.6.3 NSPS and NESHAP Alternative Standards and Requirements

The cited sections of Subpart OOO and Subpart AAAA both allow for alternatives to the operational standards, test methods, procedures, compliance requirements, monitoring, and record keeping, and reporting provisions to be requested in the Plan for MSW landfills:

§62.16724(d)(2) and §63.1981(d)(2) The collection and control system design plan must include any alternatives to the operational standards, test methods, procedures, compliance measures, monitoring, record keeping or reporting provisions of §62.16716 through 62.16726 [of Subpart OOO, or §63.1957 through 62.1983 of Subpart AAAA] proposed by the owner or operator.

Alternatives to the NSPS or NESHAP are proposed in **Appendix E**. Brent Run Landfill will submit alternative requests under separate cover as future needs dictate. Approval of such future requests will be updated in **Appendix E**, requiring only that section of this GCCS design plan to be updated.

4.6.4 Specifications for Active Collection Systems

As stated in **Sections 4.1 through 4.5** of this design plan, the GCCS proposed at the Brent Run Landfill complies with the specifications for active collection systems as stipulated in §62.16728 and §63.1962 of the NSPS. If future expansions of the GCCS are necessary, they will be designed to comply with the NSPS requirements or any approved alternatives.

§62.16714(b)(1) Collection system. Install and start up a collection and control system that captures the gas generated within the landfill as required by paragraphs (b)(1) through (3) and (c) of this section within 30 months after:

(ii) The first annual report in which the NMOC emission rate equals or exceeds 50 megagrams per year submitted under previously applicable regulations 40 CFR part 60, subpart WWW, 40 CFR part 62, subpart GGG, or a state plan implementing 40 CFR part 60, subpart Cc for a legacy controlled landfill or a landfill in the closed landfill subcategory...

§62.16714(b)(2) Active. An active collection system must:

June 19, 2023

(i) Be designed to handle the maximum expected gas flow rate from the entire area of the landfill that warrants control over the intended use period of the gas control system equipment:

(ii) Collect gas from each area, cell, or group of cells in the landfill in which the initial solid waste has been placed for a period of 5 years or more if active; or 2 years or more if closed or at final grade.

The GCCS will be constructed within the prescribed schedule under §62.16714(b)(2)(ii). Future expansions to the GCCS will proceed in accordance with the schedules under paragraphs (i) and (ii) of this section.

§62.16714 (b)(2)(iii) and §63.1959(b)(2)(ii)(B)(3) *Collect gas at a sufficient extraction rate*

§62.16714 (b)(2)(iv) and §63.1959(b)(2)(ii)(B)(4) *Be designed to minimize off-site migration of gas*

In compliance with §62.16714(b)(2)(ii)(A)(3-4) and §63.1959(b)(2)(ii)(B)(3-4), the proposed GCCS is designed to extract LFG at a sufficient rate to minimize the subsurface lateral migration and surface emissions of LFG. This is achieved by sizing and installing sufficient collection elements, transmission piping, blower(s), and LFG destruction equipment for the estimated maximum flow rate of LFG.

The GCCS is designed to collect LFG at a sufficient rate, which per the definitions in §62.16730 and §63.1990 means to maintain a negative gauge pressure (vacuum) at all wellheads without causing air infiltration. Application of a negative gauge pressure and minimization of air infiltration will be verified by monitoring the static pressure and nitrogen or oxygen concentrations of the LFG at the wellheads.

Each wellhead will be monitored monthly in accordance with §63.1958(b) and (c). Monitoring will be performed for pressure, temperature, oxygen and/or nitrogen, at a minimum. Verification of the GCCS's ability to minimize off-site subsurface LFG migration is achieved through the routine quarterly perimeter monitoring for combustible gases at the site.

Brent Run Landfill will monitor the GCCS wellheads, after installation, for static pressure and for LFG quality in accordance with NSPS requirements and will continue to monitor the perimeter LFG monitoring locations to detect the presence of off-site LFG migration. If off-site LFG migration is detected, the Brent Run Landfill will take the necessary actions in accordance with NSPS or NESHAP requirements.

June 19, 2023

4.6.5 Control Systems

The existing control systems (one LFG treatment system, one open flare, and one enclosed flare) have a combined maximum rated capacity of approximately 5,500 scfm. Control units operate in accordance with the work practice requirement operational standard given by §63.1958(e)(1).

Additional control devices will be installed as future LFG recovery rates dictate need. All devices will be designed and operated in accordance with the applicable citations in this section.

4.6.5.1 Flare Units

The required operational performance of the open flare is stipulated by applicable regulations of §62.16714(c) and §63.1959(b)(iii), which allow collected LFG to be controlled by:

§62.16714(c)(1) and §63.1959(b)(iii)(A) *A non-enclosed flare designed and operated in accordance with the parameters established in 40 CFR 60.18 [of Subpart OOO, or §63.11(b) of Subpart AAAA], except as noted in §63.1959 of Subpart AAAA; or*

§62.16714(c)(1) and §63.1959(b)(iii)(A) *A control system designed and operated to reduce NMOC by 98 weight percent; or when an enclosed combustion device is used for control, to either reduce NMOC by 98 weight percent or reduce the outlet NMOC concentration to less than 20 parts-per-million by volume, dry basis as hexane at 3-percent oxygen or less; or*

§62.16714(c)(3) and §63.1959(b)(2)(iii)(C) *Route the collected gas to a treatment system that processes the collected gas for subsequent sale or beneficial use such as fuel for combustion, production of vehicle fuel, production of high-Btu gas for pipeline injection, or use as a raw material in a chemical manufacturing process. Venting of treated landfill gas to the ambient air is not allowed. If the treated landfill gas cannot be routed for subsequent sale or beneficial use, then the treated landfill gas must be controlled according to either paragraph (c)(1) or (2) of this section [either paragraph (b)(2)(iii)(A) or (B) of this section for Subpart AAAA].*

The open flare unit and enclosed flare unit located on site have a combined maximum rated capacity of approximately 2,739 scfm. The open flare is non-assisted, and is designed and operated in accordance with 40 CFR §60.18. Per §62.16714(c)(1) and §63.1959(b)(iii)(A), the open flare will be operated within the parameter ranges established by the manufacturer(s) of these units. Both the open and enclosed flares are designed to reduce the concentration of the NMOC present in the LFG by at least 98 percent

June 19, 2023

by weight. This destruction is supported by design, initial performance testing per 40 CFR §60.18, and operation of the open flare in compliance with the requirements of 40 CFR §60.18 for non-assisted flares.

The blowers which convey LFG to the flares are each rated for a total inlet vacuum of 45 in. w.c. and a discharge pressure of 15 in. w.c.. It is expected that the flares will operate as backup to the LFGTE plant, based on plant downtime and process needs. However, each flare has the capability to operate 24 hours per day, seven days per week, 365 days a year, excluding the routine operations and maintenance shutdown periods that are anticipated during the typical operation of the system.

The applicable regulations list operation and monitoring requirements for a non-enclosed flare as follows:

§63.1961(c) *Each owner or operator seeking to comply with §63.1959(b)(2)(iii) using a non-enclosed flare must install, calibrate and operate according to the manufacture's specifications for the following equipment:*

§63.1961(c)(1) *A heat sensing device such as an ultraviolet beam sensor or thermocouple, at the pilot light or the flame itself to indicate the presence of a flame*

(i) *Install, calibrate, and maintain a gas flow rate measuring device that records the flow to the control device at least once every 15 minutes; and*

(ii) *Secure the bypass line in the closed position with a car-seal or lock-and-key type configuration. A visual inspection of the seal or closure mechanism must be performed at least once every month to ensure that the valve is maintained in the closed position and that the gas flow is not diverted through the bypass line.*

The applicable regulations list operation and monitoring requirements for an enclosed flare as follows:

§63.1961(b) *Each owner or operator seeking to comply with §63.1959(b)(2)(iii) using an enclosed combustor must install, calibrate and operate according to the manufacture's specifications for the following equipment:*

§63.1961(b)(1) *A temperature monitoring device equipped with a continuous recorder and having a minimum accuracy of ± 1 percent of the temperature being measured expressed in degrees Celsius or ± 0.5 degrees Celsius, whichever is greater.*

June 19, 2023

§63.1961(b)(2) *A device that records flow to the flare and bypass of the flare (if applicable). The owner or operator must*

(i) Install, calibrate, and maintain a gas flow rate measuring device that records the flow to the control device at least once every 15 minutes; and

(ii) Secure the bypass line in the closed position with a car-seal or lock-and-key type configuration. A visual inspection of the seal or closure mechanism must be performed at least once every month to ensure that the valve is maintained in the closed position and that the gas flow is not diverted through the bypass line.

In accordance with §63.1961, LFG flow rate and temperature (enclosed flare) or presence of a flame (open flare) will be monitored when either flare is in use. To ensure the presence of a flame, either a thermocouple installed at the flare tip or a UV sensor shall be utilized. The LFG flow rates will be monitored using a thermal mass flow meter, or equivalent monitoring device, installed in a metering run, downstream of the blower(s).

4.6.5.2 LFG Treatment System

As set forth in §62.16714(c)(3) and §63.1959(b)(2)(iii)(C), the owner may:

Route the collected gas to a treatment system that processes the collected gas for subsequent sale or beneficial use such as fuel for combustion... Venting of treated landfill gas to the ambient air is not allowed. If the treated landfill gas cannot be routed for subsequent sale or beneficial use, then the treated landfill gas must be controlled according to §62.16714 (c)(1) or (c)(2)/ §63.1959(b)(2)(iii)(A) or (B).

The LFGTE plant operates LFG treatment equipment which meets the definition of a control device per the definitions of §62.16730 and §63.1990. The blowers which convey LFG to the facility are each rated for a total inlet vacuum of 45 in. w.c. and a discharge pressure of 15 in. w.c. After passing through the compression, filtration, and dewatering processes of the LFG treatment system, the treated LFG undergoes combustion in one of five internal combustion engines to produce electricity for sale.

When using a treatment system as a control system for LFG, §63.1961(g) requires:

Calibrate, maintain, and operate according to the manufacturer's specifications a device that records flow to the treatment system and bypass of the treatment system (if applicable). Beginning no later than

June 19, 2023

September 27, 2021, each owner or operator must maintain and operate all monitoring systems associated with the treatment system in accordance with the site-specific treatment system monitoring plan required in § 63.1983(b)(5)(ii). The owner or operator must:

(1) Install, calibrate, and maintain a gas flow rate measuring device that records the flow to the treatment system at least every 15 minutes; and

(2) Secure the bypass line valve in the closed position with a car-seal or a lock and-key type configuration. A visual inspection of the seal or closure mechanism must be performed at least once every month to ensure that the valve is maintained in the closed position and that the gas flow is not diverted through the bypass line.

LFG flow rate to the LFG treatment system is continuously monitored. The LFG treatment system is maintained and operated in accordance with the site-specific Treatment System Monitoring Plan prepared by the owner and operator of the LFGTE Plant to satisfy the requirements of §63.1983(b)(5)(ii).

June 19, 2023

5.0 LIMITATIONS

The work product included in the attached was undertaken in full conformity with generally accepted professional consulting principles and practices and to the fullest extent as allowed by law we expressly disclaim all warranties, express or implied, including warranties of merchantability or fitness for a particular purpose. The work product was completed in full conformity with the contract with our client and this document is solely for the use and reliance of our client (unless previously agreed upon that a third party could rely on the work product) and any reliance on this work product by an unapproved outside party is at such party's risk.

The work product herein (including opinions, conclusions, suggestions, etc.) was based on the situations and circumstances as found at the time, location, scope and goal of our performance and thus should be relied upon and used by our client recognizing these considerations and limitations. Tetra Tech shall not be liable for the consequences of any change in environmental standards, practices, or regulations following the completion of our work and there is no warrant to the veracity of information provided by third parties, or the partial utilization of this work product.

APPENDIX A-1

CALCULATIONS - GAS GENERATION RATE MODELING

COMPUTATION SHEET

PROJECT TITLE: Brent Run Landfill - Gas Model Update
DESCRIPTION: Landfill Gas Modeling Projections
Prepared By: NJL Checked By: JPS Approved By: KM

PROJECT NO: 4231207
SHEET: 1
OF: 5
DATE: 5/1/2023

Given:

Landfill gas generation projections have been made utilizing the USEPA's Landfill Gas Emission Model (LandGEM) V3.03. LandGEM is based on a first-order decomposition rate equation for quantifying emissions from the decomposition of land filled waste in municipal solid waste (MSW) landfills. The software provides a relatively simple approach to estimating landfill gas emissions. Model defaults are based on empirical data from U.S. landfills. Field test data can also be used in place of model defaults when available. Further guidance on EPA test methods, Clean Air Act (CAA) regulations, and other guidance regarding landfill gas emissions and control technology requirements can be found at <http://www.epa.gov/ttnatw01/landfill/landflpg.html>.

First-Order Decomposition Rate Equation:

$$Q_{CH_4} = \sum_{i=1}^n \sum_{j=0.1}^1 kL_0 \left[\frac{M_i}{10} \right] (e^{-kt_{ij}})$$

Where:

Q_{CH_4} = annual methane generation in the year of the calculation ($m^3/year$)

i = 1-year time increment

n = (year of the calculation) - (initial year of waste acceptance)

j = 0.1-year time increment

k = methane generation rate ($year^{-1}$)

L_0 = potential methane generation capacity (m^3/Mg)

M_i = mass of waste accepted in the i^{th} year (Mg)

t_{ij} = age of the j^{th} section of waste mass M_i accepted in the i^{th} year (*decimal years*, e.g., 3.2 years)

LandGEM is considered a screening tool — the better the input data, the better the estimates. Often, there are limitations with the available data regarding waste quantity and composition, variation in design and operating practices over time, and changes occurring over time that impact the emissions potential. Changes to landfill operation, such as operating under wet conditions through leachate recirculation or other liquid additions, will result in generating more gas at a faster rate.

Site Conditions:

Waste conditions at the Brent Run Landfill have been developed based upon recorded documentation and reports from site operations personnel. Degradable waste mass (MSW and other degradable waste streams) has been utilized in projecting LFG generation rates. Fill placement activities at the Brent Run Landfill began in 1993. Given the projected site life, the landfill will close in 2053.

COMPUTATION SHEET

PROJECT TITLE: Brent Run Landfill - Gas Model Update
 DESCRIPTION: Landfill Gas Modeling Projections

PROJECT NO: 4231207
 SHEET: 2
 OF: 5
 DATE: 5/1/2023

Prepared By: NJL Checked By: JPS Approved By: KM

Year	Annual Waste Intake (ton/year)	Waste in Place (tons)	LFG Generation Rate (scfm)
1993	110,220	110,220	0
1994	521,840	632,060	53
1995	447,810	1,079,870	301
1996	230,230	1,310,100	504
1997	636,900	1,947,000	595
1998	382,800	2,329,800	877
1999	103,400	2,433,200	1,027
2000	338,800	2,772,000	1,036
2001	416,900	3,188,900	1,158
2002	227,700	3,416,600	1,313
2003	222,200	3,638,800	1,371
2004	402,600	4,041,400	1,424
2005	595,533	4,636,933	1,561
2006	541,133	5,178,066	1,786
2007	519,735	5,697,801	1,975
2008	488,387	6,186,188	2,147
2009	786,467	6,972,655	2,298
2010	743,308	7,715,963	2,585
2011	775,623	8,491,586	2,840
2012	700,492	9,192,078	3,101
2013	678,079	9,870,156	3,316
2014	478,746	10,348,902	3,511
2015	383,684	10,732,586	3,603
2016	463,613	11,196,199	3,646
2017	421,842	11,618,041	3,726
2018	515,904	12,133,945	3,782
2019	363,085	12,497,030	3,882
2020	276,169	12,773,200	3,904
2021	262,392	13,035,592	3,883
2022	258,292	13,293,884	3,857
2023	351,566	13,645,450	3,830
2024	351,566	13,997,016	3,848
2025	351,566	14,348,583	3,866
2026	351,566	14,700,149	3,883
2027	351,566	15,051,716	3,900
2028	351,566	15,403,282	3,915
2029	351,566	15,754,849	3,931
2030	351,566	16,106,415	3,945
2031	351,566	16,457,982	3,959
2032	351,566	16,809,548	3,973
2033	351,566	17,161,115	3,986
2034	351,566	17,512,681	3,998
2035	351,566	17,864,248	4,010
2036	351,566	18,215,814	4,022
2037	351,566	18,567,380	4,033
2038	351,566	18,918,947	4,043

COMPUTATION SHEET

PROJECT TITLE: Brent Run Landfill - Gas Model Update
 DESCRIPTION: Landfill Gas Modeling Projections

PROJECT NO: 4231207
 SHEET: 3
 OF: 5
 DATE: 5/1/2023

Prepared By: NJL Checked By: JPS Approved By: KM

Year	<i>Annual Waste Intake (ton/year)</i>	<i>Waste in Place (tons)</i>	<i>LFG Generation Rate (scfm)</i>
2039	351,566	19,270,513	4,054
2040	351,566	19,622,080	4,063
2041	351,566	19,973,646	4,073
2042	351,566	20,325,213	4,082
2043	351,566	20,676,779	4,090
2044	351,566	21,028,346	4,099
2045	351,566	21,379,912	4,107
2046	351,566	21,731,479	4,115
2047	351,566	22,083,045	4,122
2048	351,566	22,434,612	4,129
2049	351,566	22,786,178	4,136
2050	351,566	23,137,744	4,142
2051	351,566	23,489,311	4,149
2052	351,566	23,840,877	4,155
2053	351,566	24,192,444	4,161
2054		24,192,444	4,166
2055		24,192,444	4,003
2056		24,192,444	3,846
2057		24,192,444	3,695
2058		24,192,444	3,550
2059		24,192,444	3,411
2060		24,192,444	3,277
2061		24,192,444	3,149
2062		24,192,444	3,025
2063		24,192,444	2,907
2064		24,192,444	2,793
2065		24,192,444	2,683
2066		24,192,444	2,578
2067		24,192,444	2,477
2068		24,192,444	2,380
2069		24,192,444	2,287
2070		24,192,444	2,197
2071		24,192,444	2,111
2072		24,192,444	2,028
2073		24,192,444	1,948
2074		24,192,444	1,872
2075		24,192,444	1,799
2076		24,192,444	1,728
2077		24,192,444	1,660
2078		24,192,444	1,595
2079		24,192,444	1,533
2080		24,192,444	1,473
2081		24,192,444	1,415
2082		24,192,444	1,359
2083		24,192,444	1,306
2084		24,192,444	1,255

COMPUTATION SHEET

PROJECT TITLE: Brent Run Landfill - Gas Model Update
 DESCRIPTION: Landfill Gas Modeling Projections

PROJECT NO: 4231207
 SHEET: 4
 OF: 5
 DATE: 5/1/2023

Prepared By: NJL Checked By: JPS Approved By: KM

Year	<i>Annual Waste Intake (ton/year)</i>	<i>Waste in Place (tons)</i>	<i>LFG Generation Rate (scfm)</i>
2072		24,192,444	-
2073		24,192,444	-
2074		24,192,444	-
2075		24,192,444	-
2076		24,192,444	-
2077		24,192,444	-
2078		24,192,444	-
2079		24,192,444	-
2080		24,192,444	-
2081		24,192,444	-
2082		24,192,444	-
2083		24,192,444	-
2084		24,192,444	-
2085		24,192,444	-
2086		24,192,444	-
2087		24,192,444	-
2088		24,192,444	-
2089		24,192,444	-
2090		24,192,444	-
2091		24,192,444	-
2092		24,192,444	-
2093		24,192,444	-
2094		24,192,444	-
2095		24,192,444	-
2096		24,192,444	-
2097		24,192,444	-
2098		24,192,444	-
2099		24,192,444	-
2100		24,192,444	-
2101		24,192,444	-
2102		24,192,444	-
2103		24,192,444	-
2104		24,192,444	-
2105		24,192,444	-
2106		24,192,444	-
2107		24,192,444	-
2108		24,192,444	-
2109		24,192,444	-
2110		24,192,444	-
2111		24,192,444	-
2112		24,192,444	-
2113		24,192,444	-
2114		24,192,444	-
2115		24,192,444	-
2116		24,192,444	-
2117		24,192,444	-

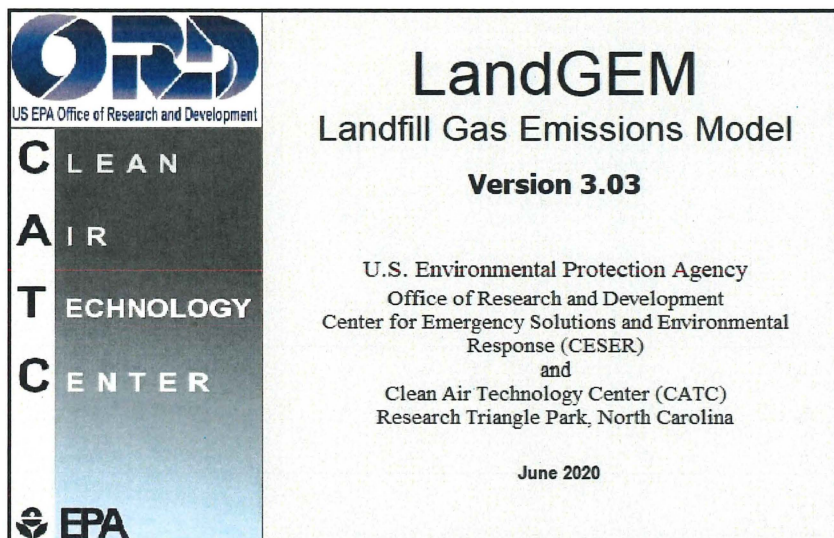

Summary Report

Landfill Name or Identifier: Brent Run Landfill - SRN: N5987

Date: Wednesday, May 3, 2023

Description/Comments:

NMOC Concentration from Tier II Sampling performed in 2001. Data through 2022 is from site records and reporting. Waste intake projections from 2023-closure are based on site projections at assumed 90% MSW. Waste Design Capacity reflects MSW only.

About LandGEM:

First-Order Decomposition Rate Equation:

$$Q_{CH_4} = \sum_{i=1}^n \sum_{j=0.1}^1 kL_o \left(\frac{M_i}{10} \right) e^{-kt_{ij}}$$

Where,

Q_{CH_4} = annual methane generation in the year of the calculation ($m^3/year$)

i = 1-year time increment

n = (year of the calculation) - (initial year of waste acceptance)

j = 0.1-year time increment

k = methane generation rate ($year^{-1}$)

L_o = potential methane generation capacity (m^3/Mg)

M_i = mass of waste accepted in the i^{th} year (Mg)

t_{ij} = age of the j^{th} section of waste mass M_i accepted in the i^{th} year (decimal years, e.g., 3.2 years)

LandGEM is based on a first-order decomposition rate equation for quantifying emissions from the decomposition of landfilled waste in municipal solid waste (MSW) landfills. The software provides a relatively simple approach to estimating landfill gas emissions. Model defaults are based on empirical data from U.S. landfills. Field test data can also be used in place of model defaults when available. Further guidance on EPA test methods, Clean Air Act (CAA) regulations, and other guidance regarding landfill gas emissions and control technology requirements can be found at <http://www.epa.gov/ttnatw01/landfill/landflpg.html>.

LandGEM is considered a screening tool — the better the input data, the better the estimates. Often, there are limitations with the available data regarding waste quantity and composition, variation in design and operating practices over time, and changes occurring over time that impact the emissions potential. Changes to landfill operation, such as operating under wet conditions through leachate recirculation or other liquid additions, will result in generating more gas at a faster rate. Defaults for estimating emissions for this type of operation are being developed to include in LandGEM along with defaults for conventional landfills (no leachate or liquid additions) for developing emission inventories and determining CAA applicability. Refer to the Web site identified above for future updates.

Input Review

LANDFILL CHARACTERISTICS

Landfill Open Year **1993**
 Landfill Closure Year (with 80-year limit) **2053**
 Actual Closure Year (without limit) **2053**
 Have Model Calculate Closure Year? **No**
 Waste Design Capacity **24,192,444** short tons

MODEL PARAMETERS

Methane Generation Rate, k **0.040** year⁻¹
 Potential Methane Generation Capacity, L₀ **100** m³/Mg
 NMOC Concentration **516** ppmv as hexane
 Methane Content **50** % by volume

GASES / POLLUTANTS SELECTED

Gas / Pollutant #1: **Total landfill gas**
 Gas / Pollutant #2: **Methane**
 Gas / Pollutant #3: **Carbon dioxide**
 Gas / Pollutant #4: **NMOC**

WASTE ACCEPTANCE RATES

Year	Waste Accepted		Waste-In-Place	
	(Mg/year)	(short tons/year)	(Mg)	(short tons)
1993	100,200	110,220	0	0
1994	474,400	521,840	100,200	110,220
1995	407,100	447,810	574,600	632,060
1996	209,300	230,230	981,700	1,079,870
1997	579,000	636,900	1,191,000	1,310,100
1998	348,000	382,800	1,770,000	1,947,000
1999	94,000	103,400	2,118,000	2,329,800
2000	308,000	338,800	2,212,000	2,433,200
2001	379,000	416,900	2,520,000	2,772,000
2002	207,000	227,700	2,899,000	3,188,900
2003	202,000	222,200	3,106,000	3,416,600
2004	366,000	402,600	3,308,000	3,638,800
2005	541,394	595,533	3,674,000	4,041,400
2006	491,939	541,133	4,215,394	4,636,933
2007	472,486	519,735	4,707,333	5,178,066
2008	443,988	488,387	5,179,819	5,697,801
2009	714,970	786,467	5,623,807	6,186,188
2010	675,735	743,308	6,338,777	6,972,655
2011	705,112	775,623	7,014,512	7,715,963
2012	636,811	700,492	7,719,624	8,491,586
2013	616,435	678,079	8,356,435	9,192,078
2014	435,224	478,746	8,972,870	9,870,156
2015	348,804	383,684	9,408,093	10,348,902
2016	421,466	463,613	9,756,897	10,732,586
2017	383,493	421,842	10,178,363	11,196,199
2018	469,004	515,904	10,561,856	11,618,041
2019	330,077	363,085	11,030,860	12,133,945
2020	251,063	276,169	11,360,937	12,497,030
2021	238,538	262,392	11,612,000	12,773,200
2022	234,811	258,292	11,850,538	13,035,592
2023	319,606	351,566	12,085,349	13,293,884
2024	319,606	351,566	12,404,955	13,645,450
2025	319,606	351,566	12,724,560	13,997,016
2026	319,606	351,566	13,044,166	14,348,583
2027	319,606	351,566	13,363,772	14,700,149
2028	319,606	351,566	13,683,378	15,051,716
2029	319,606	351,566	14,002,984	15,403,282
2030	319,606	351,566	14,322,590	15,754,849
2031	319,606	351,566	14,642,196	16,106,415
2032	319,606	351,566	14,961,802	16,457,982

WASTE ACCEPTANCE RATES (Continued)

Year	Waste Accepted		Waste-In-Place	
	(Mg/year)	(short tons/year)	(Mg)	(short tons)
2033	319,606	351,566	15,281,407	16,809,548
2034	319,606	351,566	15,601,013	17,161,115
2035	319,606	351,566	15,920,619	17,512,681
2036	319,606	351,566	16,240,225	17,864,248
2037	319,606	351,566	16,559,831	18,215,814
2038	319,606	351,566	16,879,437	18,567,380
2039	319,606	351,566	17,199,043	18,918,947
2040	319,606	351,566	17,518,649	19,270,513
2041	319,606	351,566	17,838,254	19,622,080
2042	319,606	351,566	18,157,860	19,973,646
2043	319,606	351,566	18,477,466	20,325,213
2044	319,606	351,566	18,797,072	20,676,779
2045	319,606	351,566	19,116,678	21,028,346
2046	319,606	351,566	19,436,284	21,379,912
2047	319,606	351,566	19,755,890	21,731,479
2048	319,606	351,566	20,075,496	22,083,045
2049	319,606	351,566	20,395,101	22,434,612
2050	319,606	351,566	20,714,707	22,786,178
2051	319,606	351,566	21,034,313	23,137,744
2052	319,606	351,566	21,353,919	23,489,311
2053	319,606	351,566	21,673,525	23,840,877
2054	0	0	21,993,131	24,192,444
2055	0	0	21,993,131	24,192,444
2056	0	0	21,993,131	24,192,444
2057	0	0	21,993,131	24,192,444
2058	0	0	21,993,131	24,192,444
2059	0	0	21,993,131	24,192,444
2060	0	0	21,993,131	24,192,444
2061	0	0	21,993,131	24,192,444
2062	0	0	21,993,131	24,192,444
2063	0	0	21,993,131	24,192,444
2064	0	0	21,993,131	24,192,444
2065	0	0	21,993,131	24,192,444
2066	0	0	21,993,131	24,192,444
2067	0	0	21,993,131	24,192,444
2068	0	0	21,993,131	24,192,444
2069	0	0	21,993,131	24,192,444
2070	0	0	21,993,131	24,192,444
2071	0	0	21,993,131	24,192,444
2072	0	0	21,993,131	24,192,444

Pollutant Parameters

<i>Gas / Pollutant Default Parameters:</i>				<i>User-specified Pollutant Parameters:</i>	
	Compound	Concentration (ppmv)	Molecular Weight	Concentration (ppmv)	Molecular Weight
Gases	Total landfill gas		0.00		
	Methane		16.04		
	Carbon dioxide		44.01		
	NMOC	4,000	86.18		
Pollutants	1,1,1-Trichloroethane (methyl chloroform) - HAP	0.48	133.41		
	1,1,2,2-Tetrachloroethane - HAP/VOC	1.1	167.85		
	1,1-Dichloroethane (ethylidene dichloride) - HAP/VOC	2.4	98.97		
	1,1-Dichloroethene (vinylidene chloride) - HAP/VOC	0.20	96.94		
	1,2-Dichloroethane (ethylene dichloride) - HAP/VOC	0.41	98.96		
	1,2-Dichloropropane (propylene dichloride) - HAP/VOC	0.18	112.99		
	2-Propanol (isopropyl alcohol) - VOC	50	60.11		
	Acetone	7.0	58.08		
	Acrylonitrile - HAP/VOC	6.3	53.06		
	Benzene - No or Unknown Co-disposal - HAP/VOC	1.9	78.11		
	Benzene - Co-disposal - HAP/VOC	11	78.11		
	Bromodichloromethane - VOC	3.1	163.83		
	Butane - VOC	5.0	58.12		
	Carbon disulfide - HAP/VOC	0.58	76.13		
	Carbon monoxide	140	28.01		
	Carbon tetrachloride - HAP/VOC	4.0E-03	153.84		
	Carbonyl sulfide - HAP/VOC	0.49	60.07		
	Chlorobenzene - HAP/VOC	0.25	112.56		
	Chlorodifluoromethane	1.3	86.47		
	Chloroethane (ethyl chloride) - HAP/VOC	1.3	64.52		
	Chloroform - HAP/VOC	0.03	119.39		
	Chloromethane - VOC	1.2	50.49		
	Dichlorobenzene - (HAP for para isomer/VOC)	0.21	147		
	Dichlorodifluoromethane	16	120.91		
	Dichlorofluoromethane - VOC	2.6	102.92		
	Dichloromethane (methylene chloride) - HAP	14	84.94		
	Dimethyl sulfide (methyl sulfide) - VOC	7.8	62.13		
Ethane	890	30.07			
Ethanol - VOC	27	46.08			

Pollutant Parameters (Continued)

Gas / Pollutant Default Parameters:

User-specified Pollutant Parameters:

	Gas / Pollutant Default Parameters:		User-specified Pollutant Parameters:		
	Compound	Concentration (ppmv)	Molecular Weight	Concentration (ppmv)	Molecular Weight
Pollutants	Ethyl mercaptan (ethanethiol) - VOC	2.3	62.13		
	Ethylbenzene - HAP/VOC	4.6	106.16		
	Ethylene dibromide - HAP/VOC	1.0E-03	187.88		
	Fluorotrichloromethane - VOC	0.76	137.38		
	Hexane - HAP/VOC	6.6	86.18		
	Hydrogen sulfide	36	34.08		
	Mercury (total) - HAP	2.9E-04	200.61		
	Methyl ethyl ketone - HAP/VOC	7.1	72.11		
	Methyl isobutyl ketone - HAP/VOC	1.9	100.16		
	Methyl mercaptan - VOC	2.5	48.11		
	Pentane - VOC	3.3	72.15		
	Perchloroethylene (tetrachloroethylene) - HAP	3.7	165.83		
	Propane - VOC	11	44.09		
	t-1,2-Dichloroethene - VOC	2.8	96.94		
	Toluene - No or Unknown Co-disposal - HAP/VOC	39	92.13		
	Toluene - Co-disposal - HAP/VOC	170	92.13		
	Trichloroethylene (trichloroethene) - HAP/VOC	2.8	131.40		
	Vinyl chloride - HAP/VOC	7.3	62.50		
	Xylenes - HAP/VOC	12	106.16		

Graphs

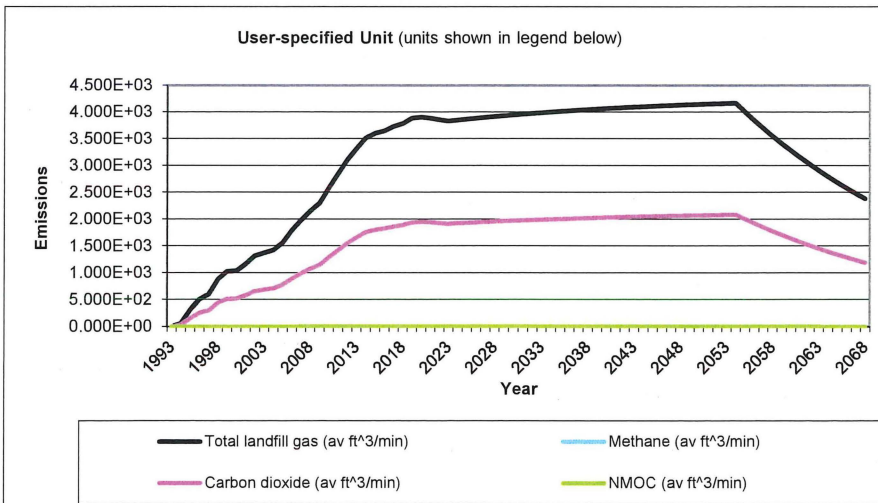
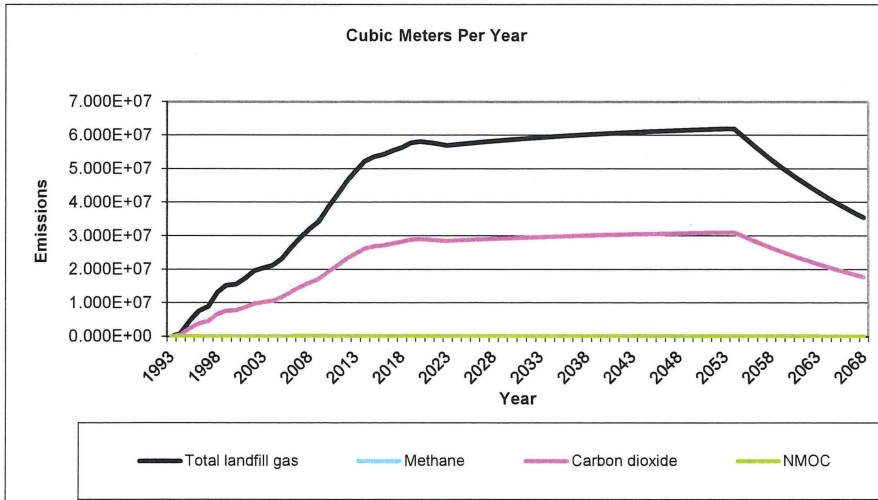
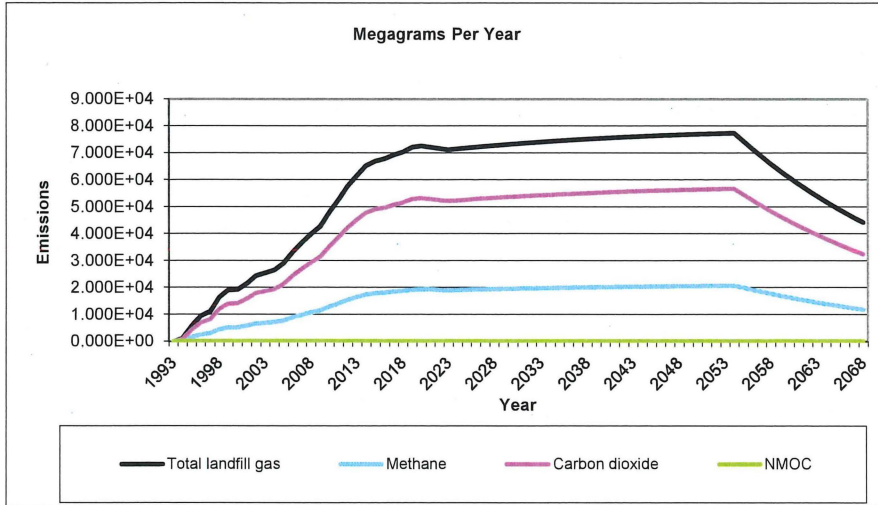

Results

Year	Total landfill gas			Methane		
	(Mg/year)	(m ³ /year)	(av ft ³ /min)	(Mg/year)	(m ³ /year)	(av ft ³ /min)
1993	0	0	0	0	0	0
1994	9.833E+02	7.874E+05	5.290E+01	2.626E+02	3.937E+05	2.645E+01
1995	5.600E+03	4.484E+06	3.013E+02	1.496E+03	2.242E+06	1.506E+02
1996	9.375E+03	7.507E+06	5.044E+02	2.504E+03	3.754E+06	2.522E+02
1997	1.106E+04	8.858E+06	5.951E+02	2.955E+03	4.429E+06	2.976E+02
1998	1.631E+04	1.306E+07	8.775E+02	4.356E+03	6.530E+06	4.387E+02
1999	1.908E+04	1.528E+07	1.027E+03	5.098E+03	7.641E+06	5.134E+02
2000	1.926E+04	1.542E+07	1.036E+03	5.144E+03	7.711E+06	5.181E+02
2001	2.153E+04	1.724E+07	1.158E+03	5.750E+03	8.619E+06	5.791E+02
2002	2.440E+04	1.954E+07	1.313E+03	6.518E+03	9.770E+06	6.564E+02
2003	2.548E+04	2.040E+07	1.371E+03	6.805E+03	1.020E+07	6.853E+02
2004	2.646E+04	2.119E+07	1.424E+03	7.068E+03	1.059E+07	7.118E+02
2005	2.901E+04	2.323E+07	1.561E+03	7.750E+03	1.162E+07	7.805E+02
2006	3.319E+04	2.658E+07	1.786E+03	8.865E+03	1.329E+07	8.928E+02
2007	3.671E+04	2.940E+07	1.975E+03	9.807E+03	1.470E+07	9.877E+02
2008	3.991E+04	3.196E+07	2.147E+03	1.066E+04	1.598E+07	1.074E+03
2009	4.270E+04	3.419E+07	2.298E+03	1.141E+04	1.710E+07	1.149E+03
2010	4.804E+04	3.847E+07	2.585E+03	1.283E+04	1.924E+07	1.292E+03
2011	5.279E+04	4.227E+07	2.840E+03	1.410E+04	2.114E+07	1.420E+03
2012	5.764E+04	4.616E+07	3.101E+03	1.540E+04	2.308E+07	1.551E+03
2013	6.163E+04	4.935E+07	3.316E+03	1.646E+04	2.468E+07	1.658E+03
2014	6.526E+04	5.226E+07	3.511E+03	1.743E+04	2.613E+07	1.756E+03
2015	6.697E+04	5.363E+07	3.603E+03	1.789E+04	2.682E+07	1.802E+03
2016	6.777E+04	5.427E+07	3.646E+03	1.810E+04	2.713E+07	1.823E+03
2017	6.925E+04	5.545E+07	3.726E+03	1.850E+04	2.773E+07	1.863E+03
2018	7.030E+04	5.629E+07	3.782E+03	1.878E+04	2.815E+07	1.891E+03
2019	7.214E+04	5.777E+07	3.882E+03	1.927E+04	2.888E+07	1.941E+03
2020	7.255E+04	5.810E+07	3.904E+03	1.938E+04	2.905E+07	1.952E+03
2021	7.217E+04	5.779E+07	3.883E+03	1.928E+04	2.890E+07	1.942E+03
2022	7.168E+04	5.740E+07	3.857E+03	1.915E+04	2.870E+07	1.928E+03
2023	7.118E+04	5.700E+07	3.830E+03	1.901E+04	2.850E+07	1.915E+03
2024	7.152E+04	5.727E+07	3.848E+03	1.910E+04	2.864E+07	1.924E+03
2025	7.185E+04	5.754E+07	3.866E+03	1.919E+04	2.877E+07	1.933E+03
2026	7.217E+04	5.779E+07	3.883E+03	1.928E+04	2.890E+07	1.942E+03
2027	7.248E+04	5.804E+07	3.900E+03	1.936E+04	2.902E+07	1.950E+03
2028	7.277E+04	5.827E+07	3.915E+03	1.944E+04	2.914E+07	1.958E+03
2029	7.306E+04	5.850E+07	3.931E+03	1.951E+04	2.925E+07	1.965E+03
2030	7.333E+04	5.872E+07	3.945E+03	1.959E+04	2.936E+07	1.973E+03
2031	7.359E+04	5.893E+07	3.959E+03	1.966E+04	2.946E+07	1.980E+03
2032	7.384E+04	5.913E+07	3.973E+03	1.972E+04	2.956E+07	1.986E+03
2033	7.408E+04	5.932E+07	3.986E+03	1.979E+04	2.966E+07	1.993E+03
2034	7.431E+04	5.951E+07	3.998E+03	1.985E+04	2.975E+07	1.999E+03
2035	7.454E+04	5.968E+07	4.010E+03	1.991E+04	2.984E+07	2.005E+03
2036	7.475E+04	5.986E+07	4.022E+03	1.997E+04	2.993E+07	2.011E+03
2037	7.495E+04	6.002E+07	4.033E+03	2.002E+04	3.001E+07	2.016E+03
2038	7.515E+04	6.018E+07	4.043E+03	2.007E+04	3.009E+07	2.022E+03
2039	7.534E+04	6.033E+07	4.054E+03	2.012E+04	3.016E+07	2.027E+03
2040	7.552E+04	6.048E+07	4.063E+03	2.017E+04	3.024E+07	2.032E+03
2041	7.570E+04	6.062E+07	4.073E+03	2.022E+04	3.031E+07	2.036E+03
2042	7.587E+04	6.075E+07	4.082E+03	2.026E+04	3.038E+07	2.041E+03

Results (Continued)

Year	Total landfill gas			Methane		
	(Mg/year)	(m ³ /year)	(av ft ³ /min)	(Mg/year)	(m ³ /year)	(av ft ³ /min)
2043	7.603E+04	6.088E+07	4.090E+03	2.031E+04	3.044E+07	2.045E+03
2044	7.618E+04	6.100E+07	4.099E+03	2.035E+04	3.050E+07	2.049E+03
2045	7.633E+04	6.112E+07	4.107E+03	2.039E+04	3.056E+07	2.053E+03
2046	7.648E+04	6.124E+07	4.115E+03	2.043E+04	3.062E+07	2.057E+03
2047	7.661E+04	6.135E+07	4.122E+03	2.046E+04	3.067E+07	2.061E+03
2048	7.675E+04	6.145E+07	4.129E+03	2.050E+04	3.073E+07	2.065E+03
2049	7.687E+04	6.156E+07	4.136E+03	2.053E+04	3.078E+07	2.068E+03
2050	7.699E+04	6.165E+07	4.142E+03	2.057E+04	3.083E+07	2.071E+03
2051	7.711E+04	6.175E+07	4.149E+03	2.060E+04	3.087E+07	2.074E+03
2052	7.722E+04	6.184E+07	4.155E+03	2.063E+04	3.092E+07	2.077E+03
2053	7.733E+04	6.192E+07	4.161E+03	2.066E+04	3.096E+07	2.080E+03
2054	7.744E+04	6.201E+07	4.166E+03	2.068E+04	3.100E+07	2.083E+03
2055	7.440E+04	5.958E+07	4.003E+03	1.987E+04	2.979E+07	2.001E+03
2056	7.148E+04	5.724E+07	3.846E+03	1.909E+04	2.862E+07	1.923E+03
2057	6.868E+04	5.500E+07	3.695E+03	1.835E+04	2.750E+07	1.848E+03
2058	6.599E+04	5.284E+07	3.550E+03	1.763E+04	2.642E+07	1.775E+03
2059	6.340E+04	5.077E+07	3.411E+03	1.693E+04	2.538E+07	1.706E+03
2060	6.091E+04	4.878E+07	3.277E+03	1.627E+04	2.439E+07	1.639E+03
2061	5.853E+04	4.686E+07	3.149E+03	1.563E+04	2.343E+07	1.574E+03
2062	5.623E+04	4.503E+07	3.025E+03	1.502E+04	2.251E+07	1.513E+03
2063	5.403E+04	4.326E+07	2.907E+03	1.443E+04	2.163E+07	1.453E+03
2064	5.191E+04	4.157E+07	2.793E+03	1.387E+04	2.078E+07	1.396E+03
2065	4.987E+04	3.994E+07	2.683E+03	1.332E+04	1.997E+07	1.342E+03
2066	4.792E+04	3.837E+07	2.578E+03	1.280E+04	1.918E+07	1.289E+03
2067	4.604E+04	3.686E+07	2.477E+03	1.230E+04	1.843E+07	1.238E+03
2068	4.423E+04	3.542E+07	2.380E+03	1.182E+04	1.771E+07	1.190E+03
2069	4.250E+04	3.403E+07	2.287E+03	1.135E+04	1.702E+07	1.143E+03
2070	4.083E+04	3.270E+07	2.197E+03	1.091E+04	1.635E+07	1.098E+03
2071	3.923E+04	3.141E+07	2.111E+03	1.048E+04	1.571E+07	1.055E+03
2072	3.769E+04	3.018E+07	2.028E+03	1.007E+04	1.509E+07	1.014E+03
2073	3.621E+04	2.900E+07	1.948E+03	9.673E+03	1.450E+07	9.742E+02
2074	3.479E+04	2.786E+07	1.872E+03	9.294E+03	1.393E+07	9.360E+02
2075	3.343E+04	2.677E+07	1.799E+03	8.930E+03	1.338E+07	8.993E+02
2076	3.212E+04	2.572E+07	1.728E+03	8.579E+03	1.286E+07	8.641E+02
2077	3.086E+04	2.471E+07	1.660E+03	8.243E+03	1.236E+07	8.302E+02
2078	2.965E+04	2.374E+07	1.595E+03	7.920E+03	1.187E+07	7.976E+02
2079	2.849E+04	2.281E+07	1.533E+03	7.609E+03	1.141E+07	7.663E+02
2080	2.737E+04	2.192E+07	1.473E+03	7.311E+03	1.096E+07	7.363E+02
2081	2.630E+04	2.106E+07	1.415E+03	7.024E+03	1.053E+07	7.074E+02
2082	2.527E+04	2.023E+07	1.359E+03	6.749E+03	1.012E+07	6.797E+02
2083	2.428E+04	1.944E+07	1.306E+03	6.484E+03	9.719E+06	6.530E+02
2084	2.332E+04	1.868E+07	1.255E+03	6.230E+03	9.338E+06	6.274E+02
2085	2.241E+04	1.794E+07	1.206E+03	5.986E+03	8.972E+06	6.028E+02
2086	2.153E+04	1.724E+07	1.158E+03	5.751E+03	8.620E+06	5.792E+02
2087	2.069E+04	1.656E+07	1.113E+03	5.525E+03	8.282E+06	5.565E+02
2088	1.987E+04	1.591E+07	1.069E+03	5.309E+03	7.957E+06	5.347E+02
2089	1.910E+04	1.529E+07	1.027E+03	5.101E+03	7.645E+06	5.137E+02
2090	1.835E+04	1.469E+07	9.871E+02	4.901E+03	7.346E+06	4.936E+02
2091	1.763E+04	1.412E+07	9.484E+02	4.709E+03	7.058E+06	4.742E+02
2092	1.694E+04	1.356E+07	9.112E+02	4.524E+03	6.781E+06	4.556E+02
2093	1.627E+04	1.303E+07	8.755E+02	4.346E+03	6.515E+06	4.377E+02

Results (Continued)

Year	Total landfill gas			Methane		
	(Mg/year)	(m ³ /year)	(av ft ³ /min)	(Mg/year)	(m ³ /year)	(av ft ³ /min)
2094	1.563E+04	1.252E+07	8.412E+02	4.176E+03	6.260E+06	4.206E+02
2095	1.502E+04	1.203E+07	8.082E+02	4.012E+03	6.014E+06	4.041E+02
2096	1.443E+04	1.156E+07	7.765E+02	3.855E+03	5.778E+06	3.882E+02
2097	1.387E+04	1.110E+07	7.460E+02	3.704E+03	5.552E+06	3.730E+02
2098	1.332E+04	1.067E+07	7.168E+02	3.559E+03	5.334E+06	3.584E+02
2099	1.280E+04	1.025E+07	6.887E+02	3.419E+03	5.125E+06	3.443E+02
2100	1.230E+04	9.848E+06	6.617E+02	3.285E+03	4.924E+06	3.308E+02
2101	1.182E+04	9.462E+06	6.357E+02	3.156E+03	4.731E+06	3.179E+02
2102	1.135E+04	9.091E+06	6.108E+02	3.032E+03	4.545E+06	3.054E+02
2103	1.091E+04	8.734E+06	5.869E+02	2.914E+03	4.367E+06	2.934E+02
2104	1.048E+04	8.392E+06	5.638E+02	2.799E+03	4.196E+06	2.819E+02
2105	1.007E+04	8.063E+06	5.417E+02	2.690E+03	4.031E+06	2.709E+02
2106	9.674E+03	7.747E+06	5.205E+02	2.584E+03	3.873E+06	2.602E+02
2107	9.295E+03	7.443E+06	5.001E+02	2.483E+03	3.721E+06	2.500E+02
2108	8.930E+03	7.151E+06	4.805E+02	2.385E+03	3.576E+06	2.402E+02
2109	8.580E+03	6.871E+06	4.616E+02	2.292E+03	3.435E+06	2.308E+02
2110	8.244E+03	6.601E+06	4.435E+02	2.202E+03	3.301E+06	2.218E+02
2111	7.921E+03	6.342E+06	4.261E+02	2.116E+03	3.171E+06	2.131E+02
2112	7.610E+03	6.094E+06	4.094E+02	2.033E+03	3.047E+06	2.047E+02
2113	7.312E+03	5.855E+06	3.934E+02	1.953E+03	2.927E+06	1.967E+02
2114	7.025E+03	5.625E+06	3.780E+02	1.876E+03	2.813E+06	1.890E+02
2115	6.749E+03	5.405E+06	3.631E+02	1.803E+03	2.702E+06	1.816E+02
2116	6.485E+03	5.193E+06	3.489E+02	1.732E+03	2.596E+06	1.744E+02
2117	6.231E+03	4.989E+06	3.352E+02	1.664E+03	2.495E+06	1.676E+02
2118	5.986E+03	4.793E+06	3.221E+02	1.599E+03	2.397E+06	1.610E+02
2119	5.752E+03	4.606E+06	3.094E+02	1.536E+03	2.303E+06	1.547E+02
2120	5.526E+03	4.425E+06	2.973E+02	1.476E+03	2.212E+06	1.487E+02
2121	5.309E+03	4.251E+06	2.857E+02	1.418E+03	2.126E+06	1.428E+02
2122	5.101E+03	4.085E+06	2.745E+02	1.363E+03	2.042E+06	1.372E+02
2123	4.901E+03	3.925E+06	2.637E+02	1.309E+03	1.962E+06	1.318E+02
2124	4.709E+03	3.771E+06	2.534E+02	1.258E+03	1.885E+06	1.267E+02
2125	4.524E+03	3.623E+06	2.434E+02	1.208E+03	1.811E+06	1.217E+02
2126	4.347E+03	3.481E+06	2.339E+02	1.161E+03	1.740E+06	1.169E+02
2127	4.176E+03	3.344E+06	2.247E+02	1.116E+03	1.672E+06	1.124E+02
2128	4.013E+03	3.213E+06	2.159E+02	1.072E+03	1.607E+06	1.079E+02
2129	3.855E+03	3.087E+06	2.074E+02	1.030E+03	1.544E+06	1.037E+02
2130	3.704E+03	2.966E+06	1.993E+02	9.894E+02	1.483E+06	9.965E+01
2131	3.559E+03	2.850E+06	1.915E+02	9.506E+02	1.425E+06	9.574E+01
2132	3.419E+03	2.738E+06	1.840E+02	9.134E+02	1.369E+06	9.199E+01
2133	3.285E+03	2.631E+06	1.768E+02	8.775E+02	1.315E+06	8.838E+01

Results (Continued)

Year	Carbon dioxide			NMOC		
	(Mg/year)	(m ³ /year)	(av ft ³ /min)	(Mg/year)	(m ³ /year)	(av ft ³ /min)
1993	0	0	0	0	0	0
1994	7.206E+02	3.937E+05	2.645E+01	1.456E+00	4.063E+02	2.730E-02
1995	4.104E+03	2.242E+06	1.506E+02	8.294E+00	2.314E+03	1.555E-01
1996	6.871E+03	3.754E+06	2.522E+02	1.389E+01	3.874E+03	2.603E-01
1997	8.107E+03	4.429E+06	2.976E+02	1.638E+01	4.571E+03	3.071E-01
1998	1.195E+04	6.530E+06	4.387E+02	2.416E+01	6.739E+03	4.528E-01
1999	1.399E+04	7.641E+06	5.134E+02	2.827E+01	7.886E+03	5.298E-01
2000	1.411E+04	7.711E+06	5.181E+02	2.852E+01	7.958E+03	5.347E-01
2001	1.578E+04	8.619E+06	5.791E+02	3.188E+01	8.894E+03	5.976E-01
2002	1.788E+04	9.770E+06	6.564E+02	3.614E+01	1.008E+04	6.774E-01
2003	1.867E+04	1.020E+07	6.853E+02	3.773E+01	1.053E+04	7.073E-01
2004	1.939E+04	1.059E+07	7.118E+02	3.919E+01	1.093E+04	7.346E-01
2005	2.126E+04	1.162E+07	7.805E+02	4.297E+01	1.199E+04	8.055E-01
2006	2.432E+04	1.329E+07	8.928E+02	4.915E+01	1.371E+04	9.214E-01
2007	2.691E+04	1.470E+07	9.877E+02	5.438E+01	1.517E+04	1.019E+00
2008	2.925E+04	1.598E+07	1.074E+03	5.911E+01	1.649E+04	1.108E+00
2009	3.130E+04	1.710E+07	1.149E+03	6.325E+01	1.764E+04	1.186E+00
2010	3.521E+04	1.924E+07	1.292E+03	7.116E+01	1.985E+04	1.334E+00
2011	3.869E+04	2.114E+07	1.420E+03	7.819E+01	2.181E+04	1.466E+00
2012	4.224E+04	2.308E+07	1.551E+03	8.537E+01	2.382E+04	1.600E+00
2013	4.517E+04	2.468E+07	1.658E+03	9.128E+01	2.546E+04	1.711E+00
2014	4.783E+04	2.613E+07	1.756E+03	9.666E+01	2.697E+04	1.812E+00
2015	4.908E+04	2.682E+07	1.802E+03	9.919E+01	2.767E+04	1.859E+00
2016	4.967E+04	2.713E+07	1.823E+03	1.004E+02	2.800E+04	1.881E+00
2017	5.075E+04	2.773E+07	1.863E+03	1.026E+02	2.861E+04	1.923E+00
2018	5.152E+04	2.815E+07	1.891E+03	1.041E+02	2.905E+04	1.952E+00
2019	5.287E+04	2.888E+07	1.941E+03	1.068E+02	2.981E+04	2.003E+00
2020	5.317E+04	2.905E+07	1.952E+03	1.075E+02	2.998E+04	2.014E+00
2021	5.289E+04	2.890E+07	1.942E+03	1.069E+02	2.982E+04	2.004E+00
2022	5.254E+04	2.870E+07	1.928E+03	1.062E+02	2.962E+04	1.990E+00
2023	5.216E+04	2.850E+07	1.915E+03	1.054E+02	2.941E+04	1.976E+00
2024	5.242E+04	2.864E+07	1.924E+03	1.059E+02	2.955E+04	1.986E+00
2025	5.266E+04	2.877E+07	1.933E+03	1.064E+02	2.969E+04	1.995E+00
2026	5.289E+04	2.890E+07	1.942E+03	1.069E+02	2.982E+04	2.004E+00
2027	5.312E+04	2.902E+07	1.950E+03	1.073E+02	2.995E+04	2.012E+00
2028	5.334E+04	2.914E+07	1.958E+03	1.078E+02	3.007E+04	2.020E+00
2029	5.354E+04	2.925E+07	1.965E+03	1.082E+02	3.019E+04	2.028E+00
2030	5.374E+04	2.936E+07	1.973E+03	1.086E+02	3.030E+04	2.036E+00
2031	5.393E+04	2.946E+07	1.980E+03	1.090E+02	3.041E+04	2.043E+00
2032	5.412E+04	2.956E+07	1.986E+03	1.094E+02	3.051E+04	2.050E+00
2033	5.429E+04	2.966E+07	1.993E+03	1.097E+02	3.061E+04	2.057E+00
2034	5.446E+04	2.975E+07	1.999E+03	1.101E+02	3.071E+04	2.063E+00
2035	5.463E+04	2.984E+07	2.005E+03	1.104E+02	3.080E+04	2.069E+00
2036	5.478E+04	2.993E+07	2.011E+03	1.107E+02	3.089E+04	2.075E+00
2037	5.493E+04	3.001E+07	2.016E+03	1.110E+02	3.097E+04	2.081E+00
2038	5.508E+04	3.009E+07	2.022E+03	1.113E+02	3.105E+04	2.086E+00
2039	5.522E+04	3.016E+07	2.027E+03	1.116E+02	3.113E+04	2.092E+00
2040	5.535E+04	3.024E+07	2.032E+03	1.119E+02	3.121E+04	2.097E+00
2041	5.548E+04	3.031E+07	2.036E+03	1.121E+02	3.128E+04	2.102E+00
2042	5.560E+04	3.038E+07	2.041E+03	1.124E+02	3.135E+04	2.106E+00

Results (Continued)

Year	Carbon dioxide			NMOC		
	(Mg/year)	(m ³ /year)	(av ft ³ /min)	(Mg/year)	(m ³ /year)	(av ft ³ /min)
2043	5.572E+04	3.044E+07	2.045E+03	1.126E+02	3.141E+04	2.111E+00
2044	5.583E+04	3.050E+07	2.049E+03	1.128E+02	3.148E+04	2.115E+00
2045	5.594E+04	3.056E+07	2.053E+03	1.131E+02	3.154E+04	2.119E+00
2046	5.605E+04	3.062E+07	2.057E+03	1.133E+02	3.160E+04	2.123E+00
2047	5.615E+04	3.067E+07	2.061E+03	1.135E+02	3.166E+04	2.127E+00
2048	5.625E+04	3.073E+07	2.065E+03	1.137E+02	3.171E+04	2.131E+00
2049	5.634E+04	3.078E+07	2.068E+03	1.139E+02	3.176E+04	2.134E+00
2050	5.643E+04	3.083E+07	2.071E+03	1.140E+02	3.181E+04	2.138E+00
2051	5.651E+04	3.087E+07	2.074E+03	1.142E+02	3.186E+04	2.141E+00
2052	5.660E+04	3.092E+07	2.077E+03	1.144E+02	3.191E+04	2.144E+00
2053	5.668E+04	3.096E+07	2.080E+03	1.145E+02	3.195E+04	2.147E+00
2054	5.675E+04	3.100E+07	2.083E+03	1.147E+02	3.200E+04	2.150E+00
2055	5.453E+04	2.979E+07	2.001E+03	1.102E+02	3.074E+04	2.066E+00
2056	5.239E+04	2.862E+07	1.923E+03	1.059E+02	2.954E+04	1.985E+00
2057	5.034E+04	2.750E+07	1.848E+03	1.017E+02	2.838E+04	1.907E+00
2058	4.836E+04	2.642E+07	1.775E+03	9.773E+01	2.727E+04	1.832E+00
2059	4.647E+04	2.538E+07	1.706E+03	9.390E+01	2.620E+04	1.760E+00
2060	4.464E+04	2.439E+07	1.639E+03	9.022E+01	2.517E+04	1.691E+00
2061	4.289E+04	2.343E+07	1.574E+03	8.668E+01	2.418E+04	1.625E+00
2062	4.121E+04	2.251E+07	1.513E+03	8.328E+01	2.323E+04	1.561E+00
2063	3.959E+04	2.163E+07	1.453E+03	8.002E+01	2.232E+04	1.500E+00
2064	3.804E+04	2.078E+07	1.396E+03	7.688E+01	2.145E+04	1.441E+00
2065	3.655E+04	1.997E+07	1.342E+03	7.386E+01	2.061E+04	1.385E+00
2066	3.512E+04	1.918E+07	1.289E+03	7.097E+01	1.980E+04	1.330E+00
2067	3.374E+04	1.843E+07	1.238E+03	6.818E+01	1.902E+04	1.278E+00
2068	3.242E+04	1.771E+07	1.190E+03	6.551E+01	1.828E+04	1.228E+00
2069	3.115E+04	1.702E+07	1.143E+03	6.294E+01	1.756E+04	1.180E+00
2070	2.993E+04	1.635E+07	1.098E+03	6.047E+01	1.687E+04	1.134E+00
2071	2.875E+04	1.571E+07	1.055E+03	5.810E+01	1.621E+04	1.089E+00
2072	2.762E+04	1.509E+07	1.014E+03	5.582E+01	1.557E+04	1.046E+00
2073	2.654E+04	1.450E+07	9.742E+02	5.364E+01	1.496E+04	1.005E+00
2074	2.550E+04	1.393E+07	9.360E+02	5.153E+01	1.438E+04	9.660E-01
2075	2.450E+04	1.338E+07	8.993E+02	4.951E+01	1.381E+04	9.281E-01
2076	2.354E+04	1.286E+07	8.641E+02	4.757E+01	1.327E+04	8.917E-01
2077	2.262E+04	1.236E+07	8.302E+02	4.571E+01	1.275E+04	8.567E-01
2078	2.173E+04	1.187E+07	7.976E+02	4.391E+01	1.225E+04	8.231E-01
2079	2.088E+04	1.141E+07	7.663E+02	4.219E+01	1.177E+04	7.909E-01
2080	2.006E+04	1.096E+07	7.363E+02	4.054E+01	1.131E+04	7.599E-01
2081	1.927E+04	1.053E+07	7.074E+02	3.895E+01	1.087E+04	7.301E-01
2082	1.852E+04	1.012E+07	6.797E+02	3.742E+01	1.044E+04	7.014E-01
2083	1.779E+04	9.719E+06	6.530E+02	3.595E+01	1.003E+04	6.739E-01
2084	1.709E+04	9.338E+06	6.274E+02	3.454E+01	9.637E+03	6.475E-01
2085	1.642E+04	8.972E+06	6.028E+02	3.319E+01	9.259E+03	6.221E-01
2086	1.578E+04	8.620E+06	5.792E+02	3.189E+01	8.896E+03	5.977E-01
2087	1.516E+04	8.282E+06	5.565E+02	3.064E+01	8.547E+03	5.743E-01
2088	1.457E+04	7.957E+06	5.347E+02	2.944E+01	8.212E+03	5.518E-01
2089	1.400E+04	7.645E+06	5.137E+02	2.828E+01	7.890E+03	5.301E-01
2090	1.345E+04	7.346E+06	4.936E+02	2.717E+01	7.581E+03	5.093E-01
2091	1.292E+04	7.058E+06	4.742E+02	2.611E+01	7.284E+03	4.894E-01
2092	1.241E+04	6.781E+06	4.556E+02	2.508E+01	6.998E+03	4.702E-01
2093	1.193E+04	6.515E+06	4.377E+02	2.410E+01	6.724E+03	4.518E-01

Results (Continued)

Year	Carbon dioxide			NMOC		
	(Mg/year)	(m ³ /year)	(av ft ³ /min)	(Mg/year)	(m ³ /year)	(av ft ³ /min)
2094	1.146E+04	6.260E+06	4.206E+02	2.316E+01	6.460E+03	4.340E-01
2095	1.101E+04	6.014E+06	4.041E+02	2.225E+01	6.207E+03	4.170E-01
2096	1.058E+04	5.778E+06	3.882E+02	2.137E+01	5.963E+03	4.007E-01
2097	1.016E+04	5.552E+06	3.730E+02	2.054E+01	5.729E+03	3.850E-01
2098	9.764E+03	5.334E+06	3.584E+02	1.973E+01	5.505E+03	3.699E-01
2099	9.381E+03	5.125E+06	3.443E+02	1.896E+01	5.289E+03	3.554E-01
2100	9.013E+03	4.924E+06	3.308E+02	1.821E+01	5.082E+03	3.414E-01
2101	8.660E+03	4.731E+06	3.179E+02	1.750E+01	4.882E+03	3.280E-01
2102	8.320E+03	4.545E+06	3.054E+02	1.681E+01	4.691E+03	3.152E-01
2103	7.994E+03	4.367E+06	2.934E+02	1.615E+01	4.507E+03	3.028E-01
2104	7.681E+03	4.196E+06	2.819E+02	1.552E+01	4.330E+03	2.909E-01
2105	7.379E+03	4.031E+06	2.709E+02	1.491E+01	4.160E+03	2.795E-01
2106	7.090E+03	3.873E+06	2.602E+02	1.433E+01	3.997E+03	2.686E-01
2107	6.812E+03	3.721E+06	2.500E+02	1.377E+01	3.841E+03	2.580E-01
2108	6.545E+03	3.576E+06	2.402E+02	1.323E+01	3.690E+03	2.479E-01
2109	6.288E+03	3.435E+06	2.308E+02	1.271E+01	3.545E+03	2.382E-01
2110	6.042E+03	3.301E+06	2.218E+02	1.221E+01	3.406E+03	2.289E-01
2111	5.805E+03	3.171E+06	2.131E+02	1.173E+01	3.273E+03	2.199E-01
2112	5.577E+03	3.047E+06	2.047E+02	1.127E+01	3.144E+03	2.113E-01
2113	5.359E+03	2.927E+06	1.967E+02	1.083E+01	3.021E+03	2.030E-01
2114	5.148E+03	2.813E+06	1.890E+02	1.040E+01	2.903E+03	1.950E-01
2115	4.947E+03	2.702E+06	1.816E+02	9.996E+00	2.789E+03	1.874E-01
2116	4.753E+03	2.596E+06	1.744E+02	9.604E+00	2.679E+03	1.800E-01
2117	4.566E+03	2.495E+06	1.676E+02	9.228E+00	2.574E+03	1.730E-01
2118	4.387E+03	2.397E+06	1.610E+02	8.866E+00	2.473E+03	1.662E-01
2119	4.215E+03	2.303E+06	1.547E+02	8.518E+00	2.376E+03	1.597E-01
2120	4.050E+03	2.212E+06	1.487E+02	8.184E+00	2.283E+03	1.534E-01
2121	3.891E+03	2.126E+06	1.428E+02	7.863E+00	2.194E+03	1.474E-01
2122	3.739E+03	2.042E+06	1.372E+02	7.555E+00	2.108E+03	1.416E-01
2123	3.592E+03	1.962E+06	1.318E+02	7.259E+00	2.025E+03	1.361E-01
2124	3.451E+03	1.885E+06	1.267E+02	6.974E+00	1.946E+03	1.307E-01
2125	3.316E+03	1.811E+06	1.217E+02	6.701E+00	1.869E+03	1.256E-01
2126	3.186E+03	1.740E+06	1.169E+02	6.438E+00	1.796E+03	1.207E-01
2127	3.061E+03	1.672E+06	1.124E+02	6.186E+00	1.726E+03	1.159E-01
2128	2.941E+03	1.607E+06	1.079E+02	5.943E+00	1.658E+03	1.114E-01
2129	2.826E+03	1.544E+06	1.037E+02	5.710E+00	1.593E+03	1.070E-01
2130	2.715E+03	1.483E+06	9.965E+01	5.486E+00	1.531E+03	1.028E-01
2131	2.608E+03	1.425E+06	9.574E+01	5.271E+00	1.471E+03	9.880E-02
2132	2.506E+03	1.369E+06	9.199E+01	5.064E+00	1.413E+03	9.493E-02
2133	2.408E+03	1.315E+06	8.838E+01	4.866E+00	1.357E+03	9.121E-02

APPENDIX A-2

CALCULATIONS - RADIUS OF INFLUENCE AND WELL SPACING ESTIMATES

COMPUTATION SHEET

PROJECT TITLE: Brent Run Landfill PROJECT NO: 209-4231207
DESCRIPTION: Vertical Well ROI Calculation CALC NO: _____ SHEET 1 OF 6
PREPARED BY: NJL CHECKED BY: JPS APPROVED BY: KM DATE: 5/1/2023

Required: Determine the radius of influence (ROI) for vertical LFG extraction wells, using both EMCON and NSPS methods for the average flow rate condition.

Purpose: The ROI is calculated in the design of an active gas extraction system to properly locate extraction wells. The location of the extraction well will dictate the well depth, once the refuse depth is known. A detail of each well can then be created with respect to total well depth, depth to slotted pipe, applied vacuum and rate of extraction.

Although horizontal collectors are not modeled directly by this analysis, the effected flow patterns developed by horizontal collectors are analogous to those created by vertical extraction wells. The net result is that vertical well spacing criteria can be translated directly to horizontal collectors in a similar environment.

Method: The following methods were used to estimate the theoretical ROI for an LFG extraction well.

A) EMCON Method (from *Methane Generation and Recovery from Landfills*, EMCON, 1982, pg. 81)

$$Q_w = \frac{k \pi R^2 t D r}{C}$$

where: Q_w = individual extraction well LFG flow rate [L/s]
 k = conversion factor (1.157×10^{-8}) [(L/s)/(mL/day)]
 R = radius of influence [m]
 t = perforated pipe length [m]
 D = in-place refuse density [kg/m^3]
 r = methane production rate [mL/kg/day]
 C = fractional methane concentration [-]

1. Noting that the methane production rate (r) divided by the fractional methane concentration (C) is equal to the LFG production rate (G), and solving for the ROI yields:

$$R = \left(\frac{Q_w}{k \pi t D G} \right)^{1/2}$$

COMPUTATION SHEET

PROJECT TITLE: Brent Run Landfill PROJECT NO: 209-4231207
 DESCRIPTION: Vertical Well ROI Calculation CALC NO: _____ SHEET 2 OF 6
 PREPARED BY: NJL CHECKED BY: JPS APPROVED BY: KM DATE: 5/1/2023

2. Converting from metric to English units yields the following conversion factors (allowing input in English units):

Q_w (from cfm to L/s):

$$\frac{1 \text{ ft}^3}{\text{min}} \times \frac{1 \text{ min}}{60 \text{ sec}} \times \frac{28.317 \text{ L}}{\text{ft}^3} = 0.47195$$

t (from ft to m):

$$1 \text{ ft} \times \frac{0.3048 \text{ m}}{\text{ft}} = 0.3048$$

D (from lb/cy to kg/m³):

$$\frac{1 \text{ lb}}{1 \text{ cy}} \times \frac{0.4536 \text{ kg}}{1 \text{ lb}} \times \frac{1 \text{ cy}}{27 \text{ ft}^3} \times \left(\frac{1 \text{ ft}}{0.3048 \text{ m}} \right)^3 = 0.5932$$

In addition, converting G from flow per volume to flow per mass equals:

G (from cfm/cy to mL/kg/day):

$$\frac{1 \text{ ft}^3}{\text{min yd}^3} \times \left(\frac{1}{D} \times \frac{1 \text{ yd}^3}{1 \text{ lb}} \right) \times \frac{60 \text{ min}}{1 \text{ hr}} \times \frac{24 \text{ hr}}{1 \text{ day}} \times \frac{28.317 \text{ L}}{\text{ft}^3} \times \frac{1 \text{ lb}}{0.4536 \text{ kg}} \times \frac{1000 \text{ mL}}{\text{L}}$$

$$= \frac{89,895,238}{D}$$

Therefore:

$$R = \left[\frac{0.47195 Q_w}{1.157 \times 10^{-8} \pi (0.3048 t) (0.5932 D) \left(\frac{89,895,238}{D} \times G \right)} \right]^{1/2}$$

Where: R is in meters

Q_w is in cfm

t is in feet

D is in lb/cy

G is in cfm/cy

COMPUTATION SHEET

PROJECT TITLE: Brent Run Landfill PROJECT NO: 209-4231207

DESCRIPTION: Vertical Well ROI Calculation CALC NO: _____ SHEET 3 OF 6

PREPARED BY: NJL CHECKED BY: JPS APPROVED BY: KM DATE: 5/1/2023

Then:

$$R = 0.8938 \left(\frac{Q_w}{tG} \right)^{1/2}$$

Converting results from meters to feet (1 ft = 0.3048 m):

$$0.3048R = 0.8938 \left(\frac{Q_w}{tG} \right)^{1/2}$$

$$R = 2.932 \left(\frac{Q_w}{tG} \right)^{1/2}$$

B) NSPS Method (from EPA NSPS Bid, 1991, pg. G-1)

$$R = \left(\frac{Q_w DC}{\pi L \rho Q_{gen} \eta} \right)^{1/2}$$

Where: ρ = in-place density of refuse [kg/m³]
 Q_w = LFG flow rate per well [m³/s]
DC = design capacity of landfill [kg]
L = perforated pipe length [m]
 Q_{gen} = peak LFG generation rate [m³/s]
 η = system collection efficiency [%]
R = radius of influence [m]

1. Converting from metric to English units yields the following conversion factors (allowing input in English units):

Q_w (from cfm to m³/s):

$$\frac{1 \text{ ft}^3}{1 \text{ min}} \times \frac{1 \text{ min}}{60 \text{ sec}} \times \left(\frac{0.3048 \text{ m}}{\text{ft}} \right)^3 = 4.719 \times 10^{-4}$$

DC (from tons to kg):

$$1 \text{ ton} \times \frac{2,000 \text{ lb}}{1 \text{ ton}} \times \frac{0.4536 \text{ kg}}{1 \text{ lb}} = 907.2$$

COMPUTATION SHEET

PROJECT TITLE: Brent Run Landfill

PROJECT NO: 209-4231207

DESCRIPTION: Vertical Well ROI Calculation

CALC NO: _____

SHEET 4 OF 6

PREPARED BY: NJL

CHECKED BY: JPS

APPROVED BY: KM

DATE: 5/1/2023

L (from ft to m):

$$1 \text{ ft} \times \frac{0.3048 \text{ m}}{\text{ft}} = 0.3048$$

ρ (from lb/cy to kg/m³):

$$\frac{1 \text{ lb}}{\text{yd}^3} \times \frac{0.4536 \text{ kg}}{1 \text{ lb}} \times \frac{1 \text{ yd}^3}{27 \text{ ft}^3} \times \left(\frac{1 \text{ ft}}{0.3048 \text{ m}} \right)^3 = 0.5933$$

Converting results from meters to feet (1 ft = 0.3048 m):

$$0.3048R = \left[\frac{(4.719 \times 10^{-4}) Q_w (907.2) DC}{\pi (0.3048L) (0.5933\rho) (4.719 \times 10^{-4} Q_{gen}) \eta} \right]^{1/2}$$

$$R = \frac{1}{0.3048} \left[\frac{(4.719 \times 10^{-4}) Q_w (907.2) DC}{\pi (0.3048L) (0.5933\rho) (4.719 \times 10^{-4} Q_{gen}) \eta} \right]^{1/2}$$

Example Calculation:

Estimate the ROI for the following average LFG flow rate condition at the XYZ Landfill

Given:

Design Capacity	=	2.5 x 10 ⁷ tons
Collection efficiency	=	70%
Average LFG generation rate	=	2,469 scfm
In-place refuse density	=	1,400 lb/cy
Depth of well	=	100 ft
Well flow rate	=	26 scfm

COMPUTATION SHEET

PROJECT TITLE: Brent Run Landfill PROJECT NO: 209-4231207

DESCRIPTION: Vertical Well ROI Calculation CALC NO: _____ SHEET 5 OF 6

PREPARED BY: NJL CHECKED BY: JPS APPROVED BY: KM DATE: 5/1/2023

A) EMCON Method

$$R = 2.932 \left[\frac{26 \text{ scfm}}{(100 \text{ ft}) \left(\frac{2,469 \text{ scfm}}{25,000,000 \text{ tons}} \right) \left(\frac{1 \text{ ton}}{2,000 \text{ lb}} \right) \left(\frac{1,400 \text{ lb}}{1 \text{ cy}} \right)} \right]^{1/2}$$

R = 180 ft

B) NSPS Method

$$R = \frac{1}{0.3048} \left[\frac{(4.719 \times 10^{-4})(26 \text{ scfm})(907.2)(25,000,000 \text{ tons})}{\pi (0.3048)(100 \text{ ft})(0.5933)(1,400 \text{ lb / cy})(4.719 \times 10^{-4})(2,469 \text{ scfm})(0.70)} \right]^{1/2}$$

R = 215 ft

COMPUTATION SHEET

PROJECT TITLE: Brent Run Landfill PROJECT NO: 209-4231207
DESCRIPTION: Vertical Well ROI Calculation CALC NO: _____ SHEET 6 OF 6
PREPARED BY: NJL CHECKED BY: JPS APPROVED BY: KM DATE: 5/1/2023

Well Spacing

Utilizing the more conservative (EMCON) value for ROI of $R = 180$ ft for this extraction well, and applying the criteria for well spacing of:

$$\text{SPACING} = \sqrt{3} \text{ ROI}$$

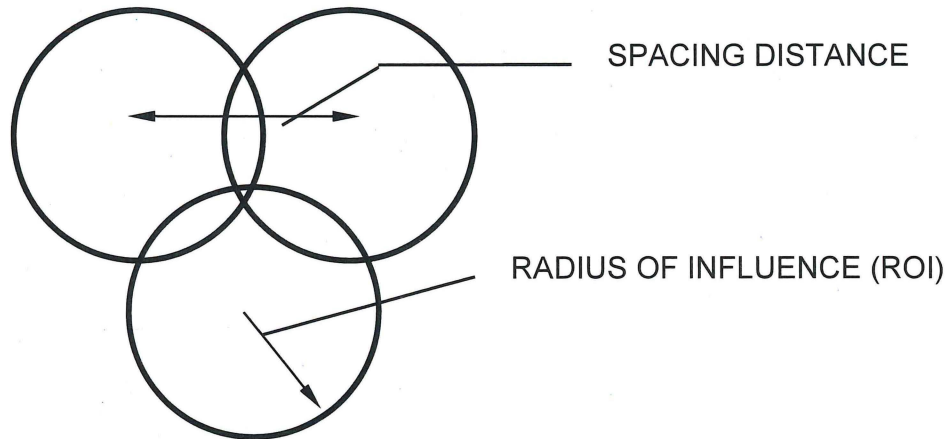

$$\underline{\underline{\text{SPACING} = 312 \text{ ft}}}$$

Site Specific Calculations:

ROI calculations for the facility are shown on the following spreadsheet. These calculations were performed for a series of typical well depths, ranging from 40 feet to 100 feet and will be utilized as the basis for determining well placement across the selected area of the Project.

**Landfill Gas Extraction Well Radius of Influence
Based on Volume of Affected Refuse
Brent Run Landfill**

Well Number ^(c)	Well Depth (ft)	LFG Flow Rate Condition	LFG Flow Rate (scfm)	Radius of Influence (ft) ^{(a)(b)}	
				NSPS	EMCON METHOD
A	40	Low	10	151	131
		Average	15	185	160
		High	20	214	185
B	60	Low	20	175	151
		Average	25	195	169
		High	30	214	185
C	80	Low	30	185	160
		Average	40	214	185
		High	50	239	207
D	100	Low	50	214	185
		Average	60	234	203
		High	70	253	219

Design Capacity	26,869,466 Mg	LFG Generation Rate	4,166 scfm
Design Tonnage	29,618,516 tons	Refuse Density	1,780 lb/cy
Design Volume	33,279,231 cy	NSPS Collection Efficiency	75 %

Average ROI of Shallow Wells (< 45 Feet in Depth)	160 feet	Well Spacing =>	277 feet
Average ROI of Medium Depth Wells (45 to 80 Feet in Depth)	177 feet	Well Spacing =>	307 feet
Average ROI of Deep Wells (>80 feet in Depth)	203 feet	Well Spacing =>	352 feet

Notes:

- a) Radius of influence based on the estimated capacity of the facility and the anticipated LFG generation rate.
- b) Calculations assume 20 feet of solid well casing from ground surface to start of perforations.
- c) Well number is general for the typical depth shown.

APPENDIX A-3

CALCULATIONS - CONDENSATE GENERATION ESTIMATES

COMPUTATION SHEET

PROJECT TITLE: Brent Run Landfill
 DESCRIPTION: Landfill Gas Design Plan
Landfill Gas Condensate Generation - Worst Case Conditions
 Prepared By: NJL Checked By: JPS

PROJECT NO: 209-4231207
 SHEET: 1
 OF: 1
 DATE: 5/1/2023

Assumptions:

1. LFG temperature at the wellhead is the warmest gas.
2. LFG traveling in a buried header will try to stabilize its temperature consistent with the ground temperature.
3. Ground temp. below the frost line remains constant year round at 59 °F
4. LFG header pipe is installed below frost depth.
5. The LFG temperature (just before the blower) depends on the distance traveled in buried header pipe and the thermal conductivity of the header pipe.
6. Work at the blower compresses the LFG, but no additional condensate is generated due to the heat of compression.

Condensate Generation (gallons/day) = (Y_{wellhead} - Y_{blower inlet}) * LFG Flow * (18 / (380 * 8.35)) * 60min/hr * 24 hrs/day

Wellhead Conditions		
P (psia)	VP (psia)	Y (moles)
14.34	0.699	0.049

Blower Inlet Conditions			
	P (psia)	VP (psia)	Y (moles)
59 °F	13.08	0.217	0.017
60 °F	13.08	0.256	0.020
70 °F	13.08	0.363	0.028
80 °F	13.08	0.507	0.039
90 °F	13.08	0.699	0.053
Y(moles) = VP/P			

Temperature vs. Vapor Pressure	
LFG Temperature (°F)	Vapor Pressure (psia)
0	0.090
35	0.100
40	0.122
45	0.147
50	0.178
55	0.217
60	0.256
65	0.310
70	0.363
75	0.435
80	0.507
85	0.603
90	0.699
95	0.825
100	0.950
105	1.115
110	1.280
115	1.485
120	1.690

LFG Flow Data		
Typical Pressure at Wellhead	-10	in. w.c.
Blower Inlet Pressure	-45	in. w.c.
Typical Wellhead Temperature	90	°F
Total Site LFG Flow	4,166	scfm

Daily Condensate Generation Rates	
59 °F	1,094
60 °F	993
70 °F	714
80 °F	339
90 °F	160

Summary: Anticipated condensate generation rate will be 1,094 gallons per day under the noted conditions.



APPENDIX B

HEADLOSS ANALYSIS

KYGAS HEADLOSS CALCULATIONS

KYGAS was developed by Dr. Don J. Wood and Dr. James E. Funk at the University of Kentucky. The program was modeled after KYPIPE, which models water distribution systems. KYGAS is used to determine head losses, system pressures, and velocities in piping systems controlled under vacuum. KYGAS operates under the assumptions that all flow in the piping system is steady, one-dimensional, isothermal flow for an ideal gas. The program uses the Darcy-Weisbach equation for head losses related to incompressible flow and the Ideal Gas Law for pressure-temperature-density relationships.

KYGAS has several useful options to develop a LFG system. The program allows the user to model any type of piping system material or configuration to coincide with field conditions. The program includes tabular and graphic interfaces for the input of information regarding the system. Multiple blower locations may be used in the program to simulate actual field conditions. In addition, blower performance curves may be entered into the program for comparison to operational and actual field conditions. KYGAS is capable of running multiple scenarios for any piping configuration including looped header systems. LFG flow units and pressure values at the wells are user specified for comparison to values obtained in the field.

The following parameters are required for operation of KYGAS.

- Pipe inside diameter
- Pipe length
- Minor loss coefficient
- Roughness within the pipe
- LFG flow rate into the system at each well or node
- LFG operating temperature (90°F)
- Specific gravity of the LFG (0.943)
- Ratio of specific heats (1.300)
- Absolute viscosity of LFG (2.82×10^{-6} lb*sec/ft²)

The design process begins with the development of the LFG flow rates for use in the program. The LFG flow is determined from the USEPA LandGEM LFG model. The LFG model is developed based on site specific information relating to waste inflow, composition, landfill capacity, and site life. The second step involves evaluating the conceptual design of the LFG system to be installed. Based on the conceptual design and a general understanding of the planned phasing of the landfill, the total LFG flow for a landfill is divided into various amounts to simulate varied flow rates at the wellheads over the life of the site.

As mentioned before, KYGAS allows the user to input information in either a tabular or graphical method. The graphical method is called KYCAD. KYCAD allows the user to input the piping network to scale in an AutoCAD format. The user constructs the system in the computer by drawing the system as it will appear in the field, and then adjusts the necessary pipe lengths and locations of wells (nodes) as required. Site specific conditions are considered when laying out a system. No elevations are used for the various nodes in this analysis. It is assumed that all LFG flow will proceed through the system regardless of node elevations.

Once all of the required information is in the program, the user can begin to evaluate the system. Evaluation of the system is an iterative process. The initial design is based on the engineer's previous design experience for similar sized systems. Once the results of the initial model are reviewed, the iterative process begins by balancing the system to control LFG velocity, pressure loss, and pipe diameter for various parts of the system. The initial flow rates and their input locations into the system remain unchanged throughout this process. The main factor adjusted for every iteration is the pipe diameter. The inside pipe diameter determines the LFG velocity and pressure drop in each pipe. Once the velocities in the system piping and the vacuum pressure remaining at the furthest node meet design requirements, the engineer may proceed with developing and finalizing the system for construction.

The design criteria for the wellfield header system are:

<i>Maximum Counter-Current Velocity</i>	<i>25 fps</i>
<i>Maximum Counter-Current Pressure Drop</i>	<i>1" w.c. per 100 feet of pipe, or 0.36 psig per 1000 feet of pipe</i>

The results of the KYGAS analysis indicate a total system pressure drop of approximately 7.1 in. w.c. (Junction 31). Please refer to the attached KYGAS output files. The maximum pressure drop is 0.12 psig per 1000 feet of pipe (Pipes P-155, P-103). All headers where flow velocity exceeds 25 fps were designed to provide con-current LFG flow; therefore, the maximum counter-current velocity was not applicable. All values are within allowable operational ranges.

Brent Run Landfill
Landfill Gas Collection and Control System

Junction Name

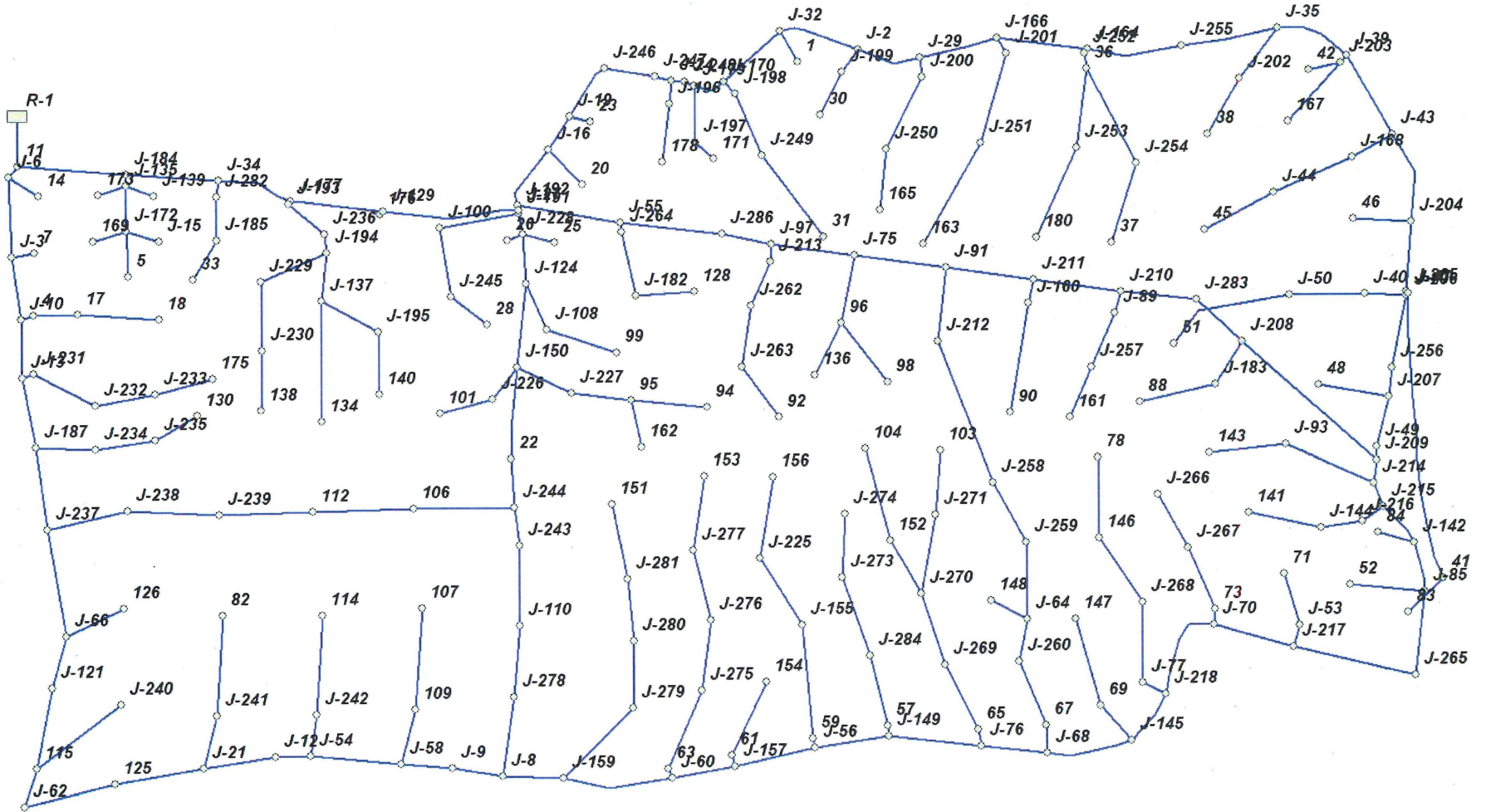

Brent Run Landfill
Landfill Gas Collection and Control System

Pipe Name

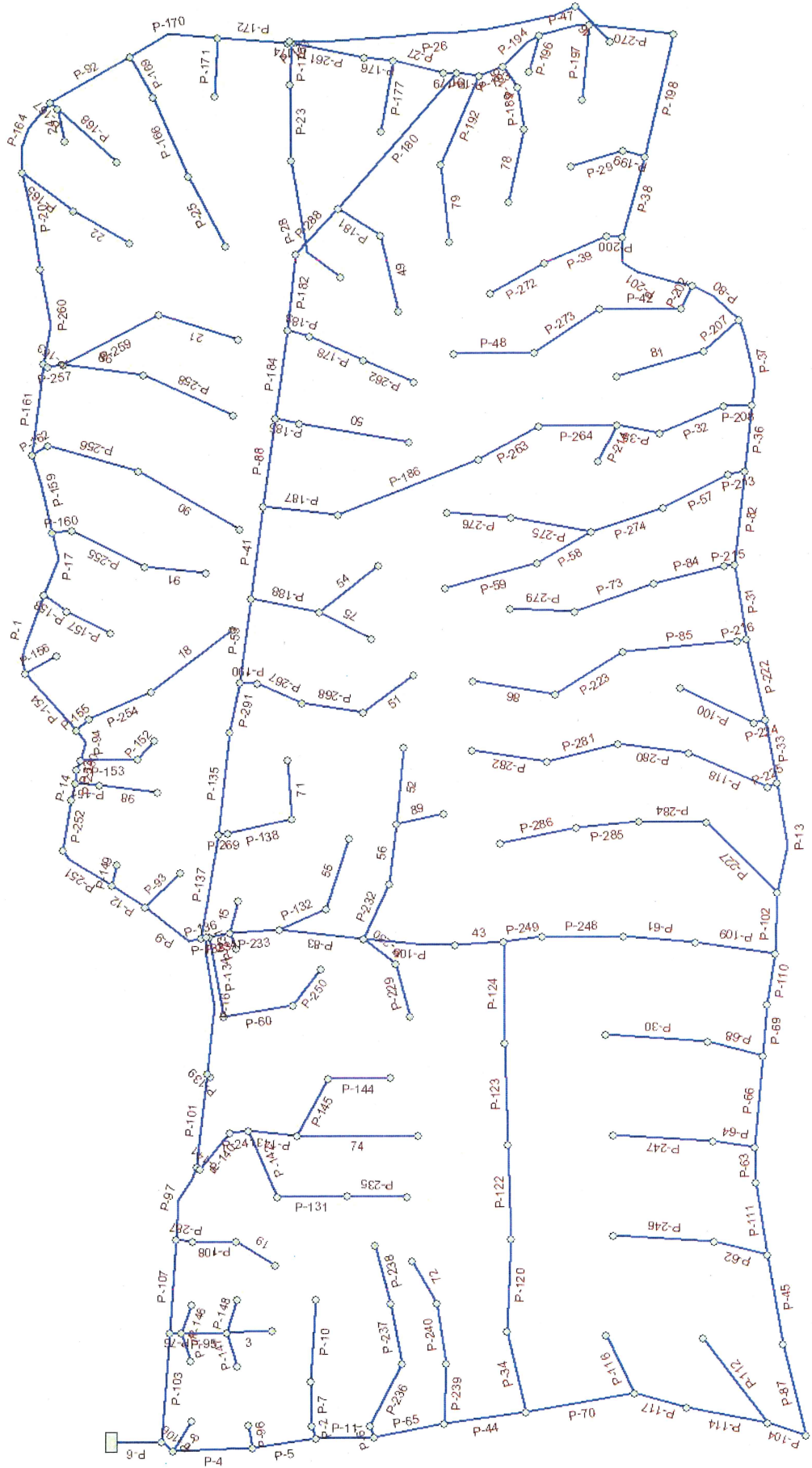

Brent Run Landfill
Landfill Gas Collection and Control System

Junction LFG Demand (scfm)

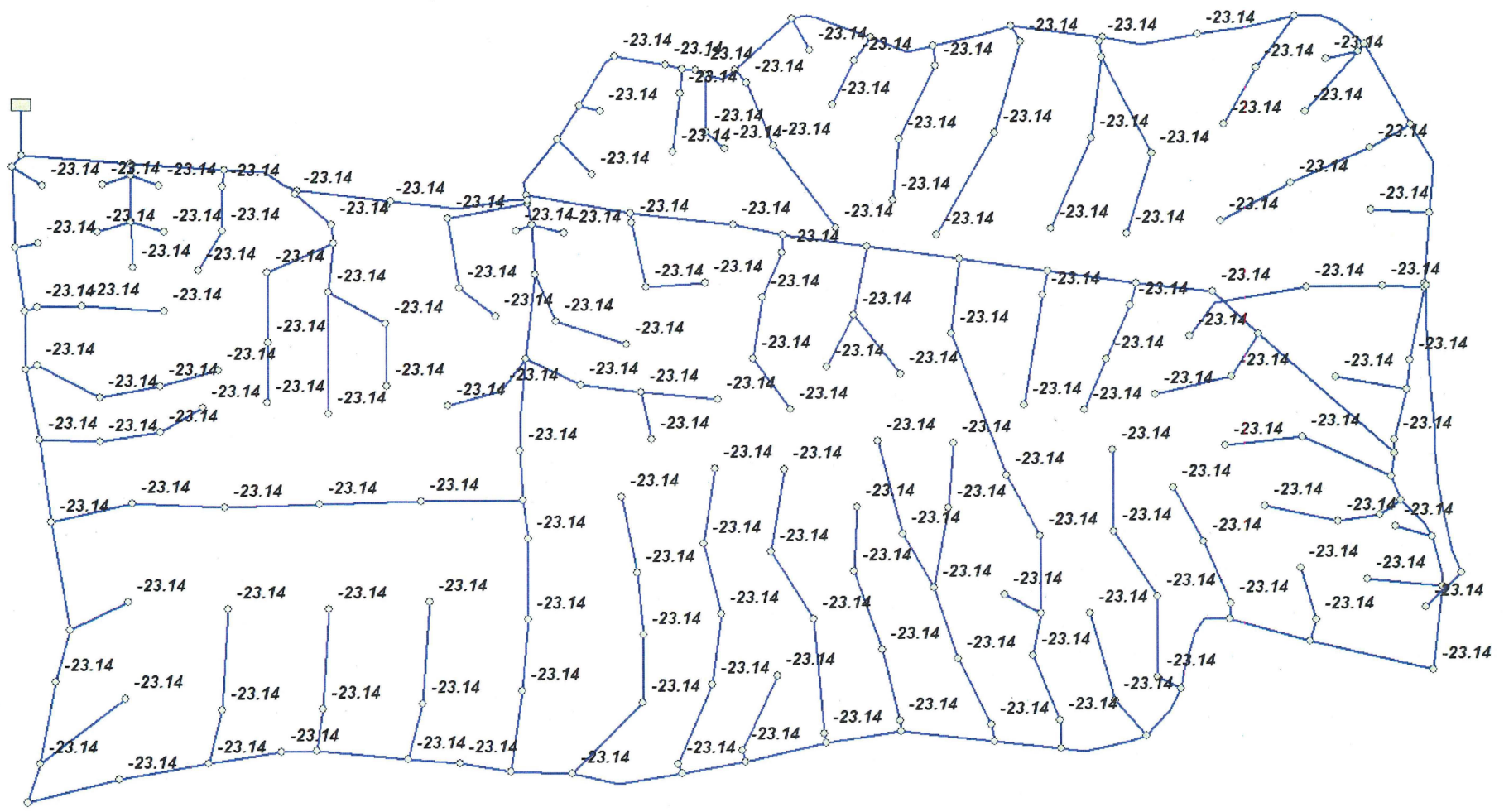

Brent Run Landfill
Landfill Gas Collection and Control System

Pipe Diameter (in.)

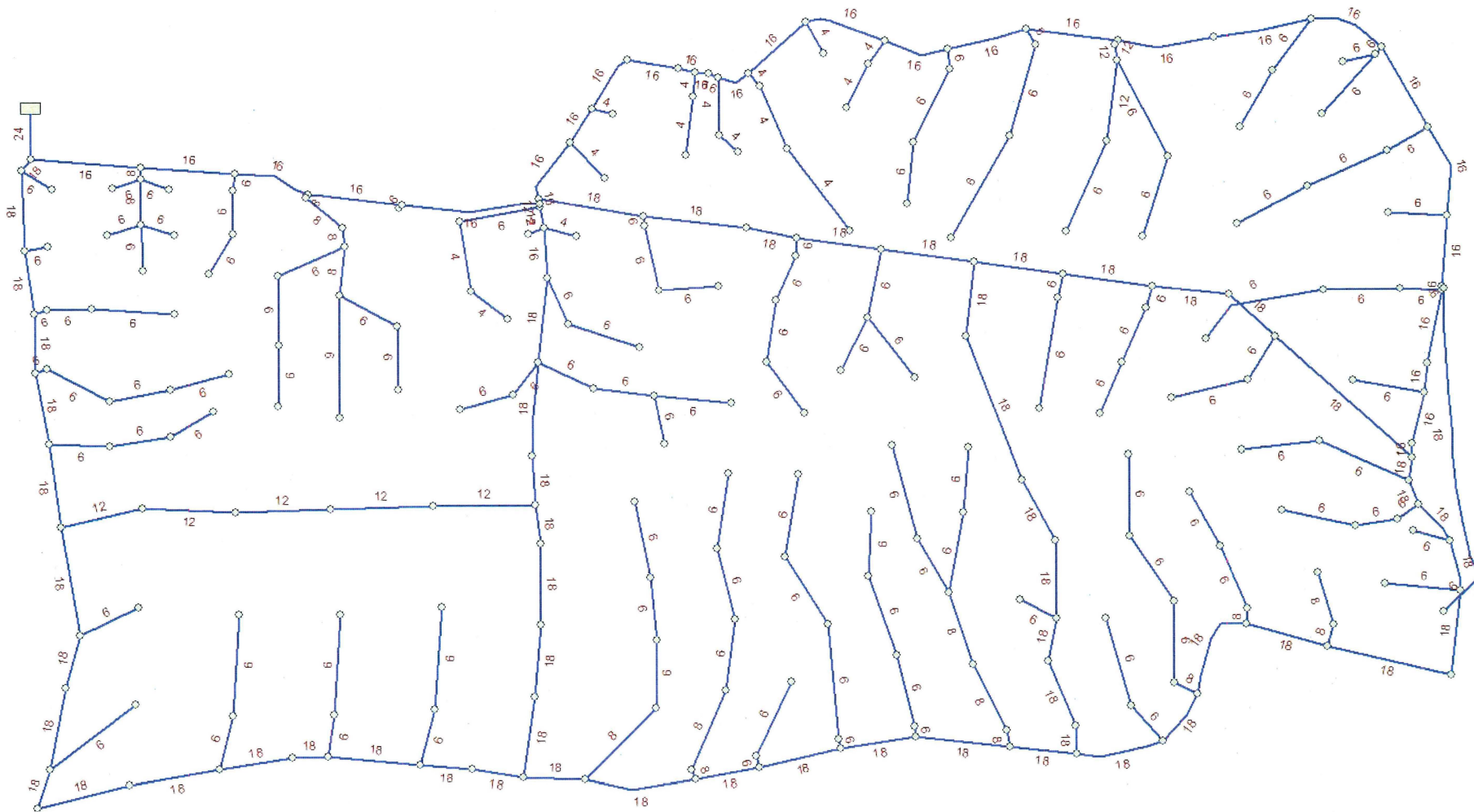

Brent Run Landfill
Landfill Gas Collection and Control System

Pipe Flow (scfm)

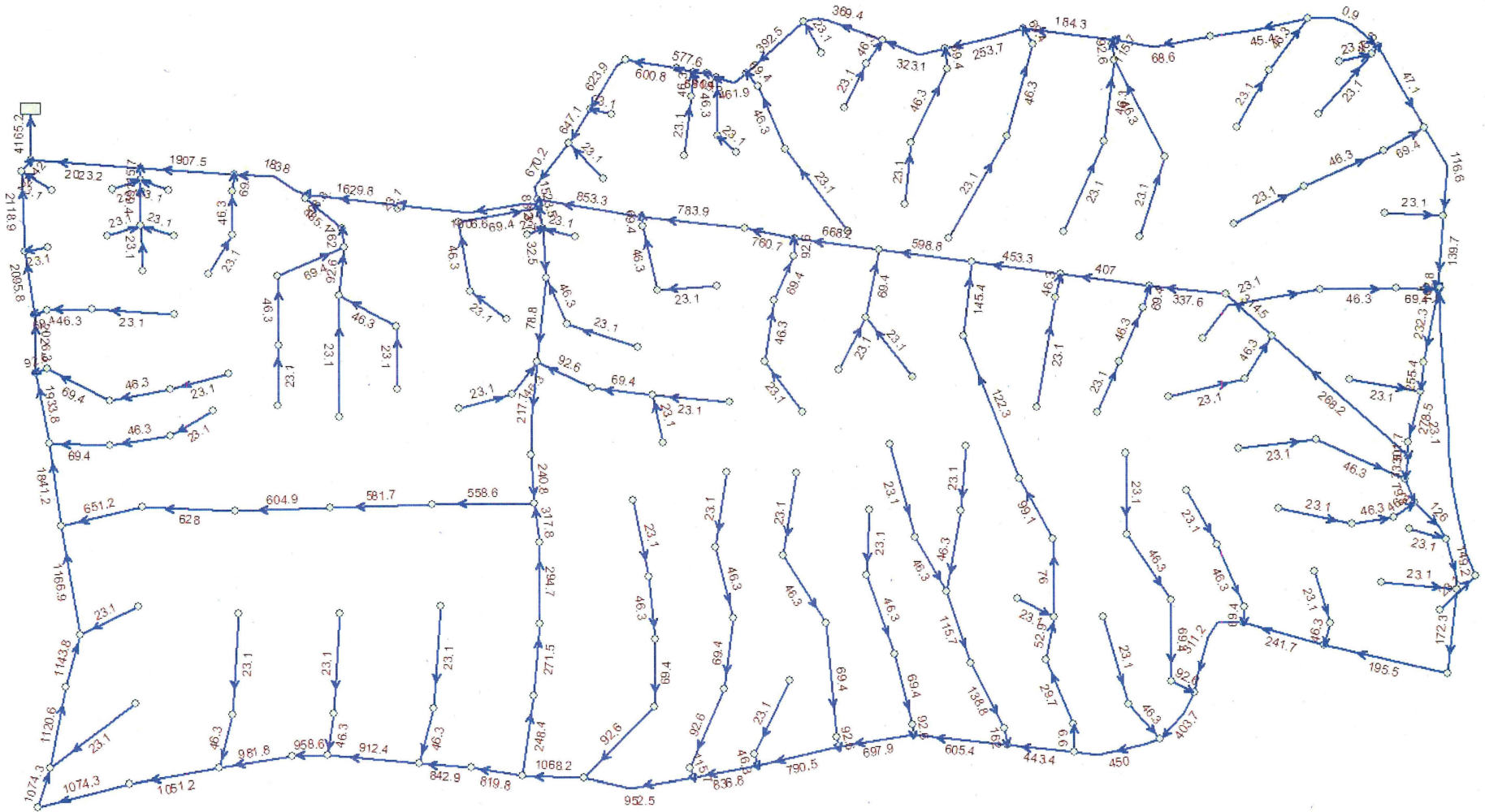

Brent Run Landfill
Landfill Gas Collection and Control System

Pipe Velocity (fps)

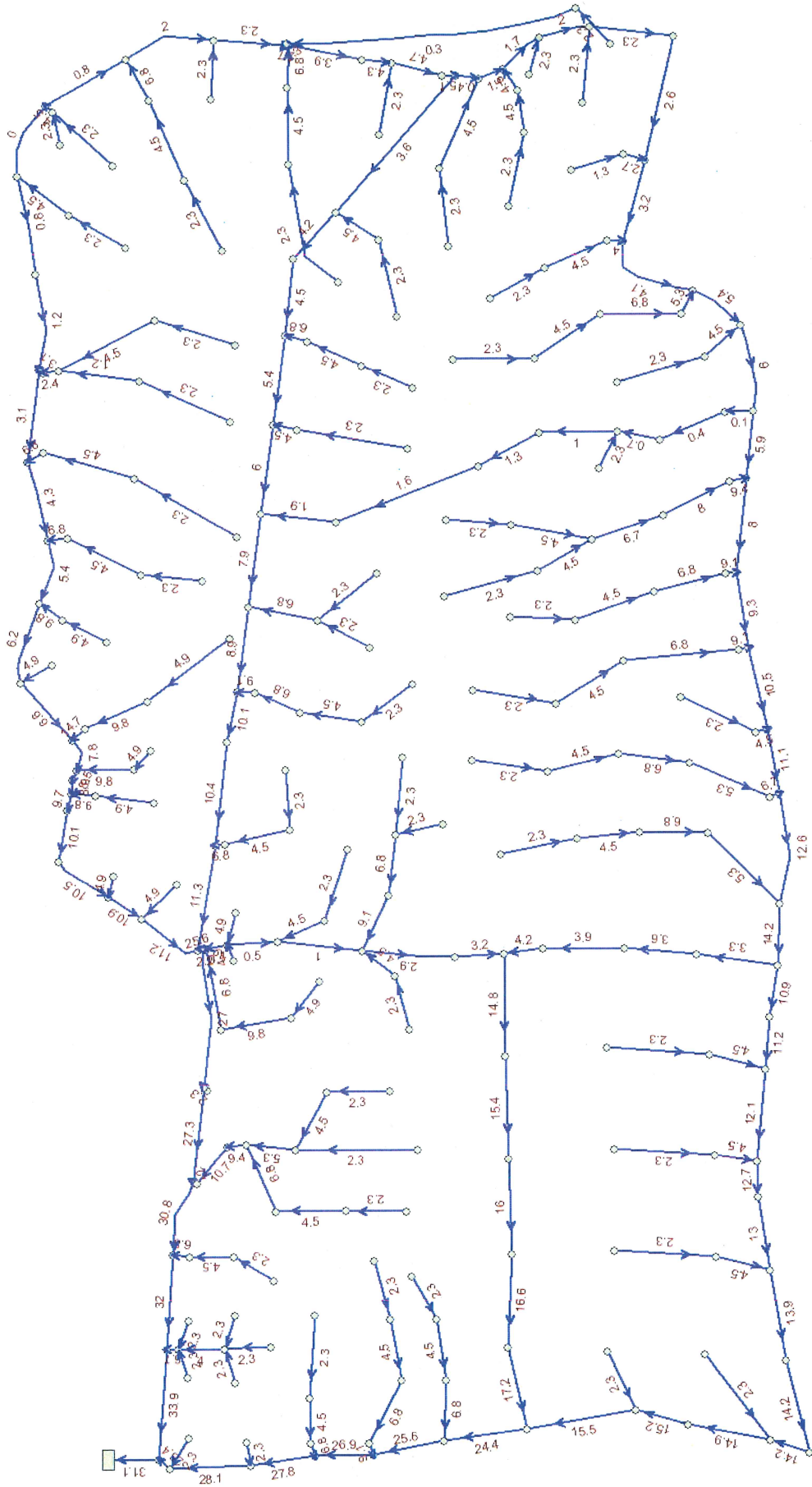

Brent Run 2023 GCCS Design Plan

```

* * * * * K Y G A S * * * * *
*
* Gas Network Analysis Software (KYGAS)
*
* CopyRighted by KYPIPE LLC (www.kypipe.com)
* Version: 11.112 01-27-2023
* Company: TETRAWIN Serial #: 580297
* Interface: KYnetic
* Licensed for Pipe2022
*
* * * * *
    
```

```

INPUT DATA FILE NAME FOR THIS SIMULATION = x:\projects\BRENT~1\423120~1\GCCSD
E~1\APPEND~4\kygas\WVBR-2~2.KYP\wvbr-202.DAT
OUTPUT DATA FILE NAME FOR THIS SIMULATION = x:\projects\BRENT~1\423120~1\GCCSD
E~1\APPEND~4\kygas\WVBR-2~2.KYP\wvbr-202.OT2
    
```

```

DATE FOR THIS COMPUTER RUN      : 4-25-2023
START TIME FOR THIS COMPUTER RUN : 14:42:49:28
    
```

SUMMARY OF DISTRIBUTION SYSTEM CHARACTERISTICS:

```

-----
NUMBER OF PIPES           = 254
NUMBER OF JUNCTION NODES = 249

UNITS SPECIFIED           = ENGLISH
    
```

```

A CONSTANT DENSITY FLUID IS SPECIFIED - DENSITY = .07POUNDS/CUBIC FOOT
ABSOLUTE VISCOSITY                   = .280E-06 POUND SECONDS/SQUARE FOOT
    
```

```

USER SPEC. FLOW UNITS (USFU) = SCF/MIN
USER SPEC. PRESSURE UNITS(USPU) = INCHES OF WATER (GAUGE)
    
```

----- SIMULATION DESCRIPTION -----

----- SUMMARY OF PIPE NETWORK GEOMETRIC AND OPERATING DATA -----

PIPE NAME	NODE #1	NODE #2	LENGTH (FT.)	DIAM. (IN.)	ROUGHNESS (MILLIFEET)	SUM-M FACT.	PUMP ID	ELEVATION CHANGE
3	5	J-172	116.0	5.8	.100	1.8	0	.0
15	25	J-228	84.0	3.9	.100	1.8	0	.0
18	31	J-249	257.0	3.9	.100	1.8	0	.0
19	33	J-185	114.0	5.8	.100	1.8	0	.0

Brent Run 2023 GCCS Design Plan

21	37	J-254	208.0	5.8	.100	1.8	0	.0
22	38	J-202	162.0	5.8	.100	1.8	0	.0
24	42	J-203	80.0	5.8	.100	1.8	0	.0
43	22	J-244	122.0	15.8	.100	1.8	0	.0
46	83	41	121.0	5.8	.100	1.8	0	.0
49	88	J-183	192.0	5.8	.100	1.8	0	.0
50	90	J-160	278.0	5.8	.100	1.8	0	.0
51	92	J-263	156.0	5.8	.100	1.8	0	.0
52	94	95	193.0	5.8	.100	1.8	0	.0
54	98	96	189.0	5.8	.100	1.8	0	.0
55	99	J-108	184.0	5.8	.100	1.8	0	.0
56	95	J-227	149.0	5.8	.100	1.8	0	.0
71	128	J-182	148.0	5.8	.100	1.8	0	.0
72	130	J-235	123.0	5.8	.100	1.8	0	.0
74	134	J-137	302.0	5.8	.100	1.8	0	.0
75	136	96	146.0	5.8	.100	1.8	0	.0
78	141	J-144	183.0	5.8	.100	1.8	0	.0
79	143	J-93	190.0	5.8	.100	1.8	0	.0
81	147	69	226.0	5.8	.100	1.8	0	.0
86	156	J-225	207.0	5.8	.100	1.8	0	.0
89	162	95	122.0	5.8	.100	1.8	0	.0
90	163	J-251	293.0	5.8	.100	1.8	0	.0
91	165	J-250	154.0	5.8	.100	1.8	0	.0
98	178	J-196	146.0	3.9	.100	1.8	0	.0
99	36	J-253	202.0	11.2	.100	1.8	0	.0
P-1	J-2	J-32	207.0	14.0	.100	1.8	0	.0
P-10	17	18	205.0	5.8	.100	1.8	0	.0
P-100	61	154	203.0	5.8	.100	1.8	0	.0
P-101	J-129	J-177	233.0	14.0	.100	1.8	0	.0
P-102	J-8	J-159	152.0	15.8	.100	1.8	0	.0
P-103	J-184	11	272.0	14.0	.100	1.8	0	.0
P-104	J-62	115	102.0	15.8	.100	1.8	0	.0
P-105	22	J-150	231.0	15.8	.100	1.8	0	.0
P-106	11	J-6	37.0	15.8	.100	1.8	0	.0
P-107	J-34	J-184	234.0	14.0	.100	1.8	0	.0
P-108	J-185	J-282	109.0	5.8	.100	1.8	0	.0
P-109	J-8	J-278	201.0	15.8	.100	1.8	0	.0
P-11	J-13	J-10	145.0	15.8	.100	1.8	0	.0
P-110	J-9	J-8	130.0	15.8	.100	1.8	0	.0
P-111	J-12	J-21	185.0	15.8	.100	1.8	0	.0
P-112	115	J-240	264.0	5.8	.100	1.8	0	.0
P-114	115	J-121	203.0	15.8	.100	1.8	0	.0
P-116	126	J-66	161.0	5.8	.100	1.8	0	.0
P-117	J-121	J-66	136.0	15.8	.100	1.8	0	.0
P-118	63	J-275	212.0	7.5	.100	1.8	0	.0
P-12	J-19	J-16	99.0	14.0	.100	1.8	0	.0
P-120	J-238	J-239	229.0	11.2	.100	1.8	0	.0
P-122	J-239	112	236.0	11.2	.100	1.8	0	.0
P-123	112	106	253.0	11.2	.100	1.8	0	.0
P-124	106	J-244	254.0	11.2	.100	1.8	0	.0
P-13	J-60	J-159	279.0	15.8	.100	1.8	0	.0
P-131	J-229	J-230	171.0	5.8	.100	1.8	0	.0
P-132	J-108	J-124	127.0	5.8	.100	1.8	0	.0
P-133	J-191	J-27	9.0	11.2	.100	1.8	0	.0
P-134	J-100	J-191	203.0	5.8	.100	1.8	0	.0

Brent Run 2023 GCCS Design Plan

P-135	J-55	J-286	255.0	15.8	.100	1.8	0	.0
P-136	J-27	J-192	12.0	14.0	.100	1.8	0	.0
P-137	J-55	J-192	263.0	15.8	.100	1.8	0	.0
P-138	J-182	J-264	164.0	5.8	.100	1.8	0	.0
P-139	J-129	176	10.0	5.8	.100	1.8	0	.0
P-14	J-24	J-247	41.0	14.0	.100	1.8	0	.0
P-140	J-193	J-236	119.0	7.5	.100	1.8	0	.0
P-141	J-177	J-193	10.0	7.5	.100	1.8	0	.0
P-142	J-194	J-229	181.0	5.8	.100	1.8	0	.0
P-143	J-137	J-194	121.0	7.5	.100	1.8	0	.0
P-144	J-195	140	156.0	5.8	.100	1.8	0	.0
P-145	J-195	J-137	163.0	5.8	.100	1.8	0	.0
P-146	J-139	J-135	75.0	5.8	.100	1.8	0	.0
P-147	J-172	169	88.0	5.8	.100	1.8	0	.0
P-148	J-15	J-172	87.0	5.8	.100	1.8	0	.0
P-149	J-19	23	53.0	3.9	.100	1.8	0	.0
P-150	J-179	J-248	24.0	14.0	.100	1.8	0	.0
P-151	J-24	J-196	59.0	3.9	.100	1.8	0	.0
P-152	J-197	171	63.0	3.9	.100	1.8	0	.0
P-153	J-179	J-197	142.0	3.9	.100	1.8	0	.0
P-154	J-32	J-170	189.0	14.0	.100	1.8	0	.0
P-155	J-170	J-198	42.0	3.9	.100	1.8	0	.0
P-156	J-32	1	88.0	3.9	.100	1.8	0	.0
P-157	J-199	30	122.0	3.9	.100	1.8	0	.0
P-158	J-2	J-199	69.0	3.9	.100	1.8	0	.0
P-159	J-166	J-29	201.0	14.0	.100	1.8	0	.0
P-16	J-27	J-129	344.0	14.0	.100	1.8	0	.0
P-160	J-29	J-200	50.0	5.8	.100	1.8	0	.0
P-161	J-164	J-166	228.0	14.0	.100	1.8	0	.0
P-162	J-166	J-201	43.0	5.8	.100	1.8	0	.0
P-163	J-164	J-252	11.0	11.2	.100	1.8	0	.0
P-164	J-39	J-35	196.0	14.0	.100	1.8	0	.0
P-165	J-35	J-202	158.0	5.8	.100	1.8	0	.0
P-166	J-168	J-44	214.0	5.8	.100	1.8	0	.0
P-167	J-39	J-203	24.0	5.8	.100	1.8	0	.0
P-168	J-203	167	195.0	5.8	.100	1.8	0	.0
P-169	J-43	J-168	118.0	5.8	.100	1.8	0	.0
P-17	J-29	J-2	163.0	14.0	.100	1.8	0	.0
P-170	J-204	J-43	235.0	14.0	.100	1.8	0	.0
P-171	J-204	46	145.0	5.8	.100	1.8	0	.0
P-172	J-205	J-204	175.0	14.0	.100	1.8	0	.0
P-173	J-47	J-205	8.0	5.8	.100	1.8	0	.0
P-174	J-206	J-205	11.0	14.0	.100	1.8	0	.0
P-175	J-40	J-206	105.0	5.8	.100	1.8	0	.0
P-176	J-207	J-256	73.0	14.0	.100	1.8	0	.0
P-177	J-207	48	179.0	5.8	.100	1.8	0	.0
P-178	J-89	J-257	148.0	5.8	.100	1.8	0	.0
P-179	J-209	J-49	34.0	14.0	.100	1.8	0	.0
P-180	J-208	J-209	450.0	15.8	.100	1.8	0	.0
P-181	J-208	J-183	127.0	5.8	.100	1.8	0	.0
P-182	J-210	J-283	192.0	15.8	.100	1.8	0	.0
P-183	J-89	J-210	56.0	5.8	.100	1.8	0	.0
P-184	J-211	J-210	220.0	15.8	.100	1.8	0	.0
P-185	J-160	J-211	60.0	5.8	.100	1.8	0	.0
P-186	J-212	J-258	378.0	15.8	.100	1.8	0	.0

Brent Run 2023 GCCS Design Plan

P-187	J-91	J-212	187.0	15.8	.100	1.8	0	.0
P-188	J-75	96	174.0	5.8	.100	1.8	0	.0
P-189	J-144	J-216	106.0	5.8	.100	1.8	0	.0
P-190	J-97	J-213	45.0	5.8	.100	1.8	0	.0
P-191	J-214	J-209	58.0	15.8	.100	1.8	0	.0
P-192	J-93	J-214	242.0	5.8	.100	1.8	0	.0
P-193	J-215	J-214	65.0	15.8	.100	1.8	0	.0
P-194	J-142	J-215	118.0	15.8	.100	1.8	0	.0
P-195	J-215	J-216	62.0	5.8	.100	1.8	0	.0
P-196	J-142	84	94.0	5.8	.100	1.8	0	.0
P-197	J-85	52	186.0	5.8	.100	1.8	0	.0
P-198	J-217	J-265	312.0	15.8	.100	1.8	0	.0
P-199	J-53	J-217	56.0	7.5	.100	1.8	0	.0
P-2	J-10	4	32.0	5.8	.100	1.8	0	.0
P-20	J-35	J-255	244.0	14.0	.100	1.8	0	.0
P-200	J-70	73	39.0	7.5	.100	1.8	0	.0
P-201	J-218	J-70	250.0	15.8	.100	1.8	0	.0
P-202	J-77	J-218	64.0	7.5	.100	1.8	0	.0
P-207	J-145	69	118.0	5.8	.100	1.8	0	.0
P-208	J-68	67	69.0	15.8	.100	1.8	0	.0
P-213	J-76	65	41.0	7.5	.100	1.8	0	.0
P-214	J-64	148	103.0	5.8	.100	1.8	0	.0
P-215	J-149	57	25.0	5.8	.100	1.8	0	.0
P-216	J-56	59	23.0	5.8	.100	1.8	0	.0
P-222	J-157	J-56	208.0	15.8	.100	1.8	0	.0
P-223	J-155	J-225	198.0	5.8	.100	1.8	0	.0
P-224	J-157	61	30.0	5.8	.100	1.8	0	.0
P-225	J-60	63	25.0	7.5	.100	1.8	0	.0
P-227	J-159	J-279	249.0	7.5	.100	1.8	0	.0
P-229	J-226	101	138.0	5.8	.100	1.8	0	.0
P-23	J-40	J-50	187.0	5.8	.100	1.8	0	.0
P-230	J-150	J-226	102.0	5.8	.100	1.8	0	.0
P-231	J-228	26	40.0	3.9	.100	1.8	0	.0
P-232	J-150	J-227	151.0	5.8	.100	1.8	0	.0
P-233	J-124	J-228	125.0	14.0	.100	1.8	0	.0
P-234	J-228	J-191	51.0	11.2	.100	1.8	0	.0
P-235	J-230	138	150.0	5.8	.100	1.8	0	.0
P-236	J-231	J-232	174.0	5.8	.100	1.8	0	.0
P-237	J-232	J-233	152.0	5.8	.100	1.8	0	.0
P-238	J-233	175	150.0	5.8	.100	1.8	0	.0
P-239	J-234	J-187	151.0	5.8	.100	1.8	0	.0
P-240	J-235	J-234	152.0	5.8	.100	1.8	0	.0
P-241	J-236	J-194	47.0	7.5	.100	1.8	0	.0
P-246	J-241	82	250.0	5.8	.100	1.8	0	.0
P-247	J-242	114	249.0	5.8	.100	1.8	0	.0
P-248	J-243	J-110	200.0	15.8	.100	1.8	0	.0
P-249	J-244	J-243	95.0	15.8	.100	1.8	0	.0
P-25	J-44	45	196.0	5.8	.100	1.8	0	.0
P-250	J-245	28	116.0	3.9	.100	1.8	0	.0
P-251	J-246	J-19	152.0	14.0	.100	1.8	0	.0
P-252	J-247	J-246	130.0	14.0	.100	1.8	0	.0
P-253	J-248	J-24	34.0	14.0	.100	1.8	0	.0
P-254	J-249	J-198	169.0	3.9	.100	1.8	0	.0
P-255	J-250	J-200	201.0	5.8	.100	1.8	0	.0
P-256	J-251	J-201	233.0	5.8	.100	1.8	0	.0

Brent Run 2023 GCCS Design Plan

P-257	J-252	36	38.0	11.2	.100	1.8	0	.0
P-258	J-253	180	245.0	5.8	.100	1.8	0	.0
P-259	J-254	36	269.0	5.8	.100	1.8	0	.0
P-26	J-47	41	725.0	15.8	.100	1.8	0	.0
P-260	J-255	J-164	241.0	14.0	.100	1.8	0	.0
P-261	J-256	J-206	184.0	14.0	.100	1.8	0	.0
P-262	J-257	161	137.0	5.8	.100	1.8	0	.0
P-263	J-258	J-259	172.0	15.8	.100	1.8	0	.0
P-264	J-259	J-64	193.0	15.8	.100	1.8	0	.0
P-267	J-262	J-213	122.0	5.8	.100	1.8	0	.0
P-268	J-263	J-262	154.0	5.8	.100	1.8	0	.0
P-269	J-264	J-55	22.0	5.8	.100	1.8	0	.0
P-27	J-49	J-207	130.0	14.0	.100	1.8	0	.0
P-270	J-265	J-85	211.0	15.8	.100	1.8	0	.0
P-272	J-267	J-266	153.0	5.8	.100	1.8	0	.0
P-273	J-268	146	196.0	5.8	.100	1.8	0	.0
P-274	J-269	J-270	187.0	7.5	.100	1.8	0	.0
P-275	J-270	J-271	204.0	5.8	.100	1.8	0	.0
P-276	J-271	103	161.0	5.8	.100	1.8	0	.0
P-279	J-274	J-273	161.0	5.8	.100	1.8	0	.0
P-28	J-50	51	336.0	5.8	.100	1.8	0	.0
P-280	J-275	J-276	179.0	5.8	.100	1.8	0	.0
P-281	J-276	J-277	179.0	5.8	.100	1.8	0	.0
P-282	J-277	153	189.0	5.8	.100	1.8	0	.0
P-284	J-279	J-280	167.0	5.8	.100	1.8	0	.0
P-285	J-280	J-281	156.0	5.8	.100	1.8	0	.0
P-286	J-281	151	192.0	5.8	.100	1.8	0	.0
P-287	J-282	J-34	42.0	5.8	.100	1.8	0	.0
P-288	J-283	J-208	154.0	15.8	.100	1.8	0	.0
P-29	J-53	71	136.0	7.5	.100	1.8	0	.0
P-291	J-286	J-97	127.0	15.8	.100	1.8	0	.0
P-30	107	109	255.0	5.8	.100	1.8	0	.0
P-31	J-56	J-149	187.0	15.8	.100	1.8	0	.0
P-32	J-260	67	174.0	15.8	.100	1.8	0	.0
P-33	J-60	J-157	160.0	15.8	.100	1.8	0	.0
P-34	J-238	J-237	207.0	11.2	.100	1.8	0	.0
P-35	J-64	J-260	110.0	15.8	.100	1.8	0	.0
P-36	J-76	J-68	167.0	15.8	.100	1.8	0	.0
P-37	J-68	J-145	216.0	15.8	.100	1.8	0	.0
P-38	J-70	J-217	207.0	15.8	.100	1.8	0	.0
P-39	J-267	73	170.0	5.8	.100	1.8	0	.0
P-4	J-3	J-6	197.0	15.8	.100	1.8	0	.0
P-41	J-75	J-91	233.0	15.8	.100	1.8	0	.0
P-42	J-77	J-268	200.0	5.8	.100	1.8	0	.0
P-44	J-237	J-187	206.0	15.8	.100	1.8	0	.0
P-45	J-21	125	225.0	15.8	.100	1.8	0	.0
P-47	J-85	J-142	126.0	15.8	.100	1.8	0	.0
P-48	146	78	203.0	5.8	.100	1.8	0	.0
P-5	J-10	J-3	160.0	15.8	.100	1.8	0	.0
P-53	J-97	J-75	212.0	15.8	.100	1.8	0	.0
P-57	J-269	65	183.0	7.5	.100	1.8	0	.0
P-58	J-270	152	156.0	5.8	.100	1.8	0	.0
P-59	152	104	239.0	5.8	.100	1.8	0	.0
P-6	11	R-1	126.0	21.0	.100	1.8	0	.0
P-60	J-100	J-245	174.0	3.9	.100	1.8	0	.0

Brent Run 2023 GCCS Design Plan

P-61	J-110	J-278	180.0	15.8	.100	1.8	0	.0
P-62	J-21	J-241	137.0	5.8	.100	1.8	0	.0
P-63	J-54	J-12	87.0	15.8	.100	1.8	0	.0
P-64	J-54	J-242	104.0	5.8	.100	1.8	0	.0
P-65	J-187	J-13	179.0	15.8	.100	1.8	0	.0
P-66	J-58	J-54	228.0	15.8	.100	1.8	0	.0
P-67	J-231	J-13	29.0	5.8	.100	1.8	0	.0
P-68	J-58	109	143.0	5.8	.100	1.8	0	.0
P-69	J-58	J-9	128.0	15.8	.100	1.8	0	.0
P-7	4	17	111.0	5.8	.100	1.8	0	.0
P-70	J-66	J-237	271.0	15.8	.100	1.8	0	.0
P-73	J-273	J-284	208.0	5.8	.100	1.8	0	.0
P-76	J-135	J-184	30.0	7.5	.100	1.8	0	.0
P-77	J-135	173	72.0	5.8	.100	1.8	0	.0
P-8	14	J-6	90.0	5.8	.100	1.8	0	.0
P-80	J-145	J-218	145.0	15.8	.100	1.8	0	.0
P-82	J-149	J-76	235.0	15.8	.100	1.8	0	.0
P-83	J-150	J-124	211.0	15.8	.100	1.8	0	.0
P-84	J-284	57	181.0	5.8	.100	1.8	0	.0
P-85	J-155	59	286.0	5.8	.100	1.8	0	.0
P-87	125	J-62	234.0	15.8	.100	1.8	0	.0
P-88	J-91	J-211	221.0	15.8	.100	1.8	0	.0
P-9	J-16	J-192	169.0	14.0	.100	1.8	0	.0
P-92	J-43	J-39	229.0	14.0	.100	1.8	0	.0
P-93	J-16	20	122.0	3.9	.100	1.8	0	.0
P-94	J-170	J-179	85.0	14.0	.100	1.8	0	.0
P-95	J-172	J-135	112.0	7.5	.100	1.8	0	.0
P-96	7	J-3	58.0	5.8	.100	1.8	0	.0
P-97	J-177	J-34	194.0	14.0	.100	1.8	0	.0

JUNCTION NAME	NODE TITLE	ELEV	DEMAND (USFU)	FPN PRESSURE
1		.00	-23.14	
4		.00	-23.14	
5		.00	-23.14	
7		.00	-23.14	
11		.00	.00	
14		.00	-23.14	
17		.00	-23.14	
18		.00	-23.14	
20		.00	-23.14	
22		.00	-23.14	
23		.00	-23.14	
25		.00	-23.14	
26		.00	-23.14	
28		.00	-23.14	
30		.00	-23.14	
31		.00	-23.14	
33		.00	-23.14	
36		.00	.00	
37		.00	-23.14	
38		.00	-23.14	
41		.00	.00	

Brent Run 2023 GCCS Design Plan

42	.00	-23.14
45	.00	-23.14
46	.00	-23.14
48	.00	-23.14
51	.00	-23.14
52	.00	-23.14
57	.00	-23.14
59	.00	-23.14
61	.00	-23.14
63	.00	-23.14
65	.00	-23.14
67	.00	-23.14
69	.00	-23.14
71	.00	-23.14
73	.00	-23.14
78	.00	-23.14
82	.00	-23.14
83	.00	-23.14
84	.00	-23.14
88	.00	-23.14
90	.00	-23.14
92	.00	-23.14
94	.00	-23.14
95	.00	-23.14
96	.00	-23.14
98	.00	-23.14
99	.00	-23.14
101	.00	-23.14
103	.00	-23.14
104	.00	-23.14
106	.00	-23.14
107	.00	-23.14
109	.00	-23.14
112	.00	-23.14
114	.00	-23.14
115	.00	-23.14
125	.00	-23.14
126	.00	-23.14
128	.00	-23.14
130	.00	-23.14
134	.00	-23.14
136	.00	-23.14
138	.00	-23.14
140	.00	-23.14
141	.00	-23.14
143	.00	-23.14
146	.00	-23.14
147	.00	-23.14
148	.00	-23.14
151	.00	-23.14
152	.00	-23.14
153	.00	-23.14
154	.00	-23.14
156	.00	-23.14
161	.00	-23.14

Brent Run 2023 GCCS Design Plan

162	.00	-23.14
163	.00	-23.14
165	.00	-23.14
167	.00	-23.14
169	.00	-23.14
171	.00	-23.14
173	.00	-23.14
175	.00	-23.14
176	.00	-23.14
178	.00	-23.14
180	.00	-23.14
J-10	.00	.00
J-100	.00	-23.14
J-108	.00	-23.14
J-110	.00	-23.14
J-12	.00	-23.14
J-121	.00	-23.14
J-124	.00	.00
J-129	.00	.00
J-13	.00	.00
J-135	.00	.00
J-137	.00	-23.14
J-139	.00	-23.14
J-142	.00	.00
J-144	.00	-23.14
J-145	.00	.00
J-149	.00	.00
J-15	.00	-23.14
J-150	.00	.00
J-155	.00	-23.14
J-157	.00	.00
J-159	.00	-23.14
J-16	.00	.00
J-160	.00	-23.14
J-164	.00	.00
J-166	.00	.00
J-168	.00	-23.14
J-170	.00	.00
J-172	.00	.00
J-177	.00	.00
J-179	.00	.00
J-182	.00	-23.14
J-183	.00	-23.14
J-184	.00	.00
J-185	.00	-23.14
J-187	.00	-23.14
J-19	.00	.00
J-191	.00	.00
J-192	.00	.00
J-193	.00	-23.14
J-194	.00	.00
J-195	.00	-23.14
J-196	.00	-23.14
J-197	.00	-23.14
J-198	.00	-23.14

Brent Run 2023 GCCS Design Plan

J-199	.00	-23.14
J-2	.00	.00
J-200	.00	-23.14
J-201	.00	-23.14
J-202	.00	-23.14
J-203	.00	.00
J-204	.00	.00
J-205	.00	.00
J-206	.00	.00
J-207	.00	.00
J-208	.00	.00
J-209	.00	.00
J-21	.00	-23.14
J-210	.00	.00
J-211	.00	.00
J-212	.00	-23.14
J-213	.00	-23.14
J-214	.00	.00
J-215	.00	.00
J-216	.00	.00
J-217	.00	.00
J-218	.00	.00
J-225	.00	-23.14
J-226	.00	-23.14
J-227	.00	-23.14
J-228	.00	.00
J-229	.00	-23.14
J-230	.00	-23.14
J-231	.00	-23.14
J-232	.00	-23.14
J-233	.00	-23.14
J-234	.00	-23.14
J-235	.00	-23.14
J-236	.00	-23.14
J-237	.00	-23.14
J-238	.00	-23.14
J-239	.00	-23.14
J-24	.00	.00
J-240	.00	-23.14
J-241	.00	-23.14
J-242	.00	-23.14
J-243	.00	-23.14
J-244	.00	.00
J-245	.00	-23.14
J-246	.00	-23.14
J-247	.00	-23.14
J-248	.00	-23.14
J-249	.00	-23.14
J-250	.00	-23.14
J-251	.00	-23.14
J-252	.00	-23.14
J-253	.00	-23.14
J-254	.00	-23.14
J-255	.00	-23.14
J-256	.00	-23.14

Brent Run 2023 GCCS Design Plan

J-257	.00	-23.14
J-258	.00	-23.14
J-259	.00	-23.14
J-260	.00	-23.14
J-262	.00	-23.14
J-263	.00	-23.14
J-264	.00	-23.14
J-265	.00	-23.14
J-266	.00	-23.14
J-267	.00	-23.14
J-268	.00	-23.14
J-269	.00	-23.14
J-27	.00	.00
J-270	.00	-23.14
J-271	.00	-23.14
J-273	.00	-23.14
J-274	.00	-23.14
J-275	.00	-23.14
J-276	.00	-23.14
J-277	.00	-23.14
J-278	.00	-23.14
J-279	.00	-23.14
J-280	.00	-23.14
J-281	.00	-23.14
J-282	.00	-23.14
J-283	.00	-23.14
J-284	.00	-23.14
J-286	.00	-23.14
J-29	.00	.00
J-3	.00	.00
J-32	.00	.00
J-34	.00	.00
J-35	.00	.00
J-39	.00	.00
J-40	.00	-23.14
J-43	.00	.00
J-44	.00	-23.14
J-47	.00	.00
J-49	.00	-23.14
J-50	.00	-23.14
J-53	.00	-23.14
J-54	.00	.00
J-55	.00	.00
J-56	.00	.00
J-58	.00	-23.14
J-6	.00	.00
J-60	.00	.00
J-62	.00	.00
J-64	.00	.00
J-66	.00	.00
J-68	.00	.00
J-70	.00	.00
J-75	.00	.00
J-76	.00	.00
J-77	.00	-23.14

Brent Run 2023 GCCS Design Plan

J-8	.00	.00	
J-85	.00	.00	
J-89	.00	-23.14	
J-9	.00	-23.14	
J-91	.00	.00	
J-93	.00	-23.14	
J-97	.00	.00	
R-1	.00	.00	-45.00

=====
Set = 0

=====
RESULTS FOR THIS SIMULATION FOLLOW
=====

Solution was obtained in 20 trials
Flow Accuracy = .6338E-03[< .500E-02]
RV Accuracy = .0000E+00[< .100E-02]

PIPE NO.	NODE #1	NODE #2	FLOW (USFU)	LOSS (USPU)	VELOCITY (FT/S)	DENSITY (#/CF)	FRICTION FACTOR	AREA RATIO
3	5	J-172	23.140	.01	2.26	.0710	.0326	
15	25	J-228	23.140	.05	4.91	.0710	.0296	
18	31	J-249	23.140	.13	4.91	.0710	.0296	
19	33	J-185	23.140	.01	2.26	.0710	.0326	
21	37	J-254	23.140	.02	2.26	.0710	.0326	
22	38	J-202	23.140	.01	2.26	.0710	.0326	
24	42	J-203	23.140	.01	2.26	.0710	.0326	
43	22	J-244	240.802	.01	3.19	.0710	.0231	
46	83	41	23.140	.01	2.26	.0710	.0326	
49	88	J-183	23.140	.02	2.26	.0710	.0326	
50	90	J-160	23.140	.02	2.26	.0710	.0326	
51	92	J-263	23.140	.01	2.26	.0710	.0326	
52	94	95	23.140	.02	2.26	.0710	.0326	
54	98	96	23.140	.02	2.26	.0710	.0326	
55	99	J-108	23.140	.02	2.26	.0710	.0326	
56	95	J-227	69.420	.09	6.79	.0710	.0248	
71	128	J-182	23.140	.01	2.26	.0710	.0326	
72	130	J-235	23.140	.01	2.26	.0710	.0326	
74	134	J-137	23.140	.02	2.26	.0710	.0326	
75	136	96	23.140	.01	2.26	.0710	.0326	
78	141	J-144	23.140	.02	2.26	.0710	.0326	
79	143	J-93	23.140	.02	2.26	.0710	.0326	
81	147	69	23.140	.02	2.26	.0710	.0326	
86	156	J-225	23.140	.02	2.26	.0710	.0326	
89	162	95	23.140	.01	2.26	.0710	.0326	
90	163	J-251	23.140	.02	2.26	.0710	.0326	

Brent Run 2023 GCCS Design Plan

91	165	J-250	23.140	.01	2.26	.0710	.0326
98	178	J-196	23.140	.08	4.91	.0710	.0296
99	36	J-253	-46.280	.00	1.22	.0710	.0321
P-1	J-2	J-32	369.380	.04	6.20	.0710	.0205
P-10	17	18	-23.140	.02	2.26	.0710	.0326
P-100	61	154	-23.140	.02	2.26	.0710	.0326
P-101	J-129	J-177	1629.788	.78	27.35	.0710	.0157
P-102	J-8	J-159	-1068.190	.16	14.16	.0710	.0171
P-103	J-184	11	2023.168	1.31	33.95	.0710	.0152
P-104	J-62	115	1074.348	.13	14.25	.0710	.0171
P-105	22	J-150	-217.662	.01	2.89	.0710	.0236
P-106	11	J-6	-2142.032	.38	28.40	.0710	.0153
P-107	J-34	J-184	1907.468	1.06	32.01	.0710	.0153
P-108	J-185	J-282	46.280	.03	4.53	.0710	.0273
P-109	J-8	J-278	248.382	.01	3.29	.0710	.0229
P-11	J-13	J-10	2026.332	.54	26.87	.0710	.0154
P-110	J-9	J-8	-819.808	.09	10.87	.0710	.0179
P-111	J-12	J-21	981.788	.15	13.02	.0710	.0173
P-112	115	J-240	-23.140	.02	2.26	.0710	.0326
P-114	115	J-121	1120.628	.21	14.86	.0710	.0169
P-116	126	J-66	23.140	.01	2.26	.0710	.0326
P-117	J-121	J-66	1143.768	.17	15.17	.0710	.0169
P-118	63	J-275	-92.560	.06	5.35	.0710	.0245
P-12	J-19	J-16	647.060	.08	10.86	.0710	.0184
P-120	J-238	J-239	-628.024	.36	16.60	.0710	.0179
P-122	J-239	112	-604.884	.34	15.98	.0710	.0180
P-123	112	106	-581.744	.34	15.37	.0710	.0181
P-124	106	J-244	-558.604	.31	14.76	.0710	.0182
P-13	J-60	J-159	952.490	.19	12.63	.0710	.0174
P-131	J-229	J-230	-46.280	.05	4.53	.0710	.0273
P-132	J-108	J-124	46.280	.04	4.53	.0710	.0273
P-133	J-191	J-27	83.158	.00	2.20	.0710	.0276
P-134	J-100	J-191	69.420	.12	6.79	.0710	.0248
P-135	J-55	J-286	-783.870	.12	10.39	.0710	.0181
P-136	J-27	J-192	-1523.490	.27	25.56	.0710	.0159
P-137	J-55	J-192	853.290	.15	11.31	.0710	.0178
P-138	J-182	J-264	46.280	.05	4.53	.0710	.0273
P-139	J-129	176	-23.140	.00	2.26	.0710	.0326
P-14	J-24	J-247	577.640	.05	9.69	.0710	.0188
P-140	J-193	J-236	-185.120	.14	10.69	.0710	.0211
P-141	J-177	J-193	-208.260	.07	12.03	.0710	.0207
P-142	J-194	J-229	-69.420	.11	6.79	.0710	.0248
P-143	J-137	J-194	92.560	.04	5.35	.0710	.0245
P-144	J-195	140	-23.140	.01	2.26	.0710	.0326
P-145	J-195	J-137	46.280	.05	4.53	.0710	.0273
P-146	J-139	J-135	23.140	.01	2.26	.0710	.0326
P-147	J-172	169	-23.140	.01	2.26	.0710	.0326
P-148	J-15	J-172	23.140	.01	2.26	.0710	.0326
P-149	J-19	23	-23.140	.03	4.91	.0710	.0296
P-150	J-179	J-248	508.220	.03	8.53	.0710	.0192
P-151	J-24	J-196	-46.280	.13	9.82	.0710	.0252
P-152	J-197	171	-23.140	.04	4.91	.0710	.0296
P-153	J-179	J-197	-46.280	.26	9.82	.0710	.0252
P-154	J-32	J-170	392.520	.05	6.59	.0710	.0203
P-155	J-170	J-198	-69.420	.22	14.73	.0710	.0231

Brent Run 2023 GCCS Design Plan

P-156	J-32	1	-23.140	.05	4.91	.0710	.0296
P-157	J-199	30	-23.140	.07	4.91	.0710	.0296
P-158	J-2	J-199	-46.280	.15	9.82	.0710	.0252
P-159	J-166	J-29	253.680	.02	4.26	.0710	.0223
P-16	J-27	J-129	1606.648	.99	26.96	.0710	.0157
P-160	J-29	J-200	-69.420	.04	6.79	.0710	.0248
P-161	J-164	J-166	184.260	.01	3.09	.0710	.0239
P-162	J-166	J-201	-69.420	.04	6.79	.0710	.0248
P-163	J-164	J-252	-115.700	.00	3.06	.0710	.0254
P-164	J-39	J-35	-.860	.00	.01	.0710	.0018
P-165	J-35	J-202	-46.280	.05	4.53	.0710	.0273
P-166	J-168	J-44	-46.280	.06	4.53	.0710	.0273
P-167	J-39	J-203	-46.280	.01	4.53	.0710	.0273
P-168	J-203	167	-23.140	.02	2.26	.0710	.0326
P-169	J-43	J-168	-69.420	.08	6.79	.0710	.0248
P-17	J-29	J-2	323.100	.03	5.42	.0710	.0211
P-170	J-204	J-43	-116.560	.01	1.96	.0710	.0267
P-171	J-204	46	-23.140	.01	2.26	.0710	.0326
P-172	J-205	J-204	-139.700	.01	2.34	.0710	.0256
P-173	J-47	J-205	23.140	.00	2.26	.0710	.0326
P-174	J-206	J-205	-162.840	.00	2.73	.0710	.0246
P-175	J-40	J-206	69.420	.07	6.79	.0710	.0248
P-176	J-207	J-256	-255.400	.01	4.29	.0710	.0222
P-177	J-207	48	-23.140	.02	2.26	.0710	.0326
P-178	J-89	J-257	-46.280	.04	4.53	.0710	.0273
P-179	J-209	J-49	-301.680	.01	5.06	.0710	.0214
P-180	J-208	J-209	-268.205	.03	3.56	.0710	.0225
P-181	J-208	J-183	-46.280	.04	4.53	.0710	.0273
P-182	J-210	J-283	-337.625	.02	4.48	.0710	.0214
P-183	J-89	J-210	69.420	.05	6.79	.0710	.0248
P-184	J-211	J-210	-407.045	.03	5.40	.0710	.0206
P-185	J-160	J-211	46.280	.02	4.53	.0710	.0273
P-186	J-212	J-258	-122.285	.01	1.62	.0710	.0271
P-187	J-91	J-212	-145.425	.00	1.93	.0710	.0260
P-188	J-75	96	-69.420	.11	6.79	.0710	.0248
P-189	J-144	J-216	46.280	.03	4.53	.0710	.0273
P-190	J-97	J-213	-92.560	.07	9.06	.0710	.0233
P-191	J-214	J-209	-33.475	.00	.44	.0710	.0389
P-192	J-93	J-214	46.280	.07	4.53	.0710	.0273
P-193	J-215	J-214	-79.755	.00	1.06	.0710	.0303
P-194	J-142	J-215	-126.035	.00	1.67	.0710	.0270
P-195	J-215	J-216	-46.280	.02	4.53	.0710	.0273
P-196	J-142	84	-23.140	.01	2.26	.0710	.0326
P-197	J-85	52	-23.140	.02	2.26	.0710	.0326
P-198	J-217	J-265	-195.455	.01	2.59	.0710	.0242
P-199	J-53	J-217	46.280	.01	2.67	.0710	.0290
P-2	J-10	4	-69.420	.03	6.79	.0710	.0248
P-20	J-35	J-255	45.420	.00	.76	.0710	.0343
P-200	J-70	73	-69.420	.01	4.01	.0710	.0262
P-201	J-218	J-70	-311.155	.02	4.13	.0710	.0218
P-202	J-77	J-218	92.560	.03	5.35	.0710	.0245
P-207	J-145	69	-46.280	.04	4.53	.0710	.0273
P-208	J-68	67	6.585	.00	.09	.0710	.1267
P-213	J-76	65	-161.980	.06	9.36	.0710	.0217
P-214	J-64	148	-23.140	.01	2.26	.0710	.0326

Brent Run 2023 GCCS Design Plan

P-215	J-149	57	-92.560	.05	9.06	.0710	.0233
P-216	J-56	59	-92.560	.05	9.06	.0710	.0233
P-222	J-157	J-56	-790.510	.11	10.48	.0710	.0180
P-223	J-155	J-225	-46.280	.06	4.53	.0710	.0273
P-224	J-157	61	-46.280	.02	4.53	.0710	.0273
P-225	J-60	63	-115.700	.03	6.68	.0710	.0233
P-227	J-159	J-279	-92.560	.07	5.35	.0710	.0245
P-229	J-226	101	-23.140	.01	2.26	.0710	.0326
P-23	J-40	J-50	-46.280	.05	4.53	.0710	.0273
P-230	J-150	J-226	-46.280	.03	4.53	.0710	.0273
P-231	J-228	26	-23.140	.03	4.91	.0710	.0296
P-232	J-150	J-227	-92.560	.16	9.06	.0710	.0233
P-233	J-124	J-228	-32.542	.00	.55	.0710	.0378
P-234	J-228	J-191	13.738	.00	.36	.0710	.0469
P-235	J-230	138	-23.140	.01	2.26	.0710	.0326
P-236	J-231	J-232	-69.420	.11	6.79	.0710	.0248
P-237	J-232	J-233	-46.280	.05	4.53	.0710	.0273
P-238	J-233	175	-23.140	.01	2.26	.0710	.0326
P-239	J-234	J-187	69.420	.09	6.79	.0710	.0248
P-240	J-235	J-234	46.280	.05	4.53	.0710	.0273
P-241	J-236	J-194	-161.980	.06	9.36	.0710	.0217
P-246	J-241	82	-23.140	.02	2.26	.0710	.0326
P-247	J-242	114	-23.140	.02	2.26	.0710	.0326
P-248	J-243	J-110	-294.662	.02	3.91	.0710	.0221
P-249	J-244	J-243	-317.802	.01	4.21	.0710	.0217
P-25	J-44	45	-23.140	.02	2.26	.0710	.0326
P-250	J-245	28	-23.140	.06	4.91	.0710	.0296
P-251	J-246	J-19	623.920	.10	10.47	.0710	.0185
P-252	J-247	J-246	600.780	.08	10.08	.0710	.0186
P-253	J-248	J-24	531.360	.04	8.92	.0710	.0191
P-254	J-249	J-198	46.280	.30	9.82	.0710	.0252
P-255	J-250	J-200	46.280	.06	4.53	.0710	.0273
P-256	J-251	J-201	46.280	.07	4.53	.0710	.0273
P-257	J-252	36	-92.560	.00	2.45	.0710	.0268
P-258	J-253	180	-23.140	.02	2.26	.0710	.0326
P-259	J-254	36	46.280	.07	4.53	.0710	.0273
P-26	J-47	41	-23.140	.00	.31	.0710	.0437
P-260	J-255	J-164	68.560	.00	1.15	.0710	.0306
P-261	J-256	J-206	-232.260	.02	3.90	.0710	.0227
P-262	J-257	161	-23.140	.01	2.26	.0710	.0326
P-263	J-258	J-259	-99.145	.00	1.31	.0710	.0286
P-264	J-259	J-64	-76.005	.00	1.01	.0710	.0307
P-267	J-262	J-213	69.420	.08	6.79	.0710	.0248
P-268	J-263	J-262	46.280	.05	4.53	.0710	.0273
P-269	J-264	J-55	69.420	.03	6.79	.0710	.0248
P-27	J-49	J-207	-278.540	.02	4.67	.0710	.0218
P-270	J-265	J-85	-172.315	.01	2.28	.0710	.0250
P-272	J-267	J-266	-23.140	.01	2.26	.0710	.0326
P-273	J-268	146	-46.280	.06	4.53	.0710	.0273
P-274	J-269	J-270	-115.700	.08	6.68	.0710	.0233
P-275	J-270	J-271	-46.280	.06	4.53	.0710	.0273
P-276	J-271	103	-23.140	.01	2.26	.0710	.0326
P-279	J-274	J-273	23.140	.01	2.26	.0710	.0326
P-28	J-50	51	-23.140	.03	2.26	.0710	.0326
P-280	J-275	J-276	-69.420	.11	6.79	.0710	.0248

Brent Run 2023 GCCS Design Plan

P-281	J-276	J-277	-46.280	.05	4.53	.0710	.0273
P-282	J-277	153	-23.140	.02	2.26	.0710	.0326
P-284	J-279	J-280	-69.420	.10	6.79	.0710	.0248
P-285	J-280	J-281	-46.280	.05	4.53	.0710	.0273
P-286	J-281	151	-23.140	.02	2.26	.0710	.0326
P-287	J-282	J-34	69.420	.04	6.79	.0710	.0248
P-288	J-283	J-208	-314.485	.02	4.17	.0710	.0218
P-29	J-53	71	-23.140	.00	1.34	.0710	.0350
P-291	J-286	J-97	-760.730	.08	10.09	.0710	.0182
P-30	107	109	23.140	.02	2.26	.0710	.0326
P-31	J-56	J-149	-697.950	.08	9.25	.0710	.0185
P-32	J-260	67	-29.725	.00	.39	.0710	.0402
P-33	J-60	J-157	-836.790	.10	11.10	.0710	.0178
P-34	J-238	J-237	651.164	.36	17.21	.0710	.0177
P-35	J-64	J-260	-52.865	.00	.70	.0710	.0339
P-36	J-76	J-68	-443.410	.03	5.88	.0710	.0202
P-37	J-68	J-145	-449.995	.04	5.97	.0710	.0202
P-38	J-70	J-217	-241.735	.01	3.21	.0710	.0231
P-39	J-267	73	46.280	.05	4.53	.0710	.0273
P-4	J-3	J-6	2118.892	.69	28.10	.0710	.0153
P-41	J-75	J-91	-598.750	.07	7.94	.0710	.0190
P-42	J-77	J-268	-69.420	.12	6.79	.0710	.0248
P-44	J-237	J-187	1841.212	.54	24.41	.0710	.0156
P-45	J-21	125	1051.208	.20	13.94	.0710	.0171
P-47	J-85	J-142	-149.175	.00	1.98	.0710	.0259
P-48	146	78	-23.140	.02	2.26	.0710	.0326
P-5	J-10	J-3	2095.752	.60	27.79	.0710	.0153
P-53	J-97	J-75	-668.170	.08	8.86	.0710	.0186
P-57	J-269	65	138.840	.11	8.02	.0710	.0224
P-58	J-270	152	-46.280	.05	4.53	.0710	.0273
P-59	152	104	-23.140	.02	2.26	.0710	.0326
P-6	11	R-1	4165.200	.58	31.07	.0710	.0142
P-60	J-100	J-245	-46.280	.31	9.82	.0710	.0252
P-61	J-110	J-278	-271.522	.01	3.60	.0710	.0225
P-62	J-21	J-241	-46.280	.04	4.53	.0710	.0273
P-63	J-54	J-12	958.648	.10	12.71	.0710	.0174
P-64	J-54	J-242	-46.280	.03	4.53	.0710	.0273
P-65	J-187	J-13	1933.772	.55	25.64	.0710	.0155
P-66	J-58	J-54	912.368	.15	12.10	.0710	.0176
P-67	J-231	J-13	92.560	.06	9.06	.0710	.0233
P-68	J-58	109	-46.280	.04	4.53	.0710	.0273
P-69	J-58	J-9	-842.948	.09	11.18	.0710	.0178
P-7	4	17	-46.280	.04	4.53	.0710	.0273
P-70	J-66	J-237	1166.908	.27	15.47	.0710	.0168
P-73	J-273	J-284	46.280	.06	4.53	.0710	.0273
P-76	J-135	J-184	115.700	.03	6.68	.0710	.0233
P-77	J-135	173	-23.140	.01	2.26	.0710	.0326
P-8	14	J-6	23.140	.01	2.26	.0710	.0326
P-80	J-145	J-218	-403.715	.02	5.35	.0710	.0206
P-82	J-149	J-76	-605.390	.07	8.03	.0710	.0190
P-83	J-150	J-124	-78.822	.00	1.05	.0710	.0304
P-84	J-284	57	69.420	.11	6.79	.0710	.0248
P-85	J-155	59	69.420	.16	6.79	.0710	.0248
P-87	125	J-62	1074.348	.21	14.25	.0710	.0171
P-88	J-91	J-211	-453.325	.04	6.01	.0710	.0201

Brent Run 2023 GCCS Design Plan

P-9	J-16	J-192	670.200	.12	11.25	.0710	.0183
P-92	J-43	J-39	-47.140	.00	.79	.0710	.0340
P-93	J-16	20	-23.140	.07	4.91	.0710	.0296
P-94	J-170	J-179	461.940	.04	7.75	.0710	.0196
P-95	J-172	J-135	69.420	.02	4.01	.0710	.0262
P-96	7	J-3	23.140	.01	2.26	.0710	.0326
P-97	J-177	J-34	1838.048	.88	30.84	.0710	.0154
R-1	R-1	R-1	-4165.200	.00	.01	.0710	.0319

JUNCTION	NODE	DEMAND	PRESSURE	PRESSURE	PRESSURE	DENSITY
NAME	TITLE	(USFU)	(USPU)	(PSIA)	(PSIG)	#/CF
1		-23.14	-38.48	13.31	-1.39	.071
4		-23.14	-42.72	13.15	-1.54	.071
5		-23.14	-43.05	13.14	-1.55	.071
7		-23.14	-43.35	13.13	-1.56	.071
11		.00	-44.42	13.09	-1.60	.071
14		-23.14	-44.03	13.11	-1.59	.071
17		-23.14	-42.69	13.16	-1.54	.071
18		-23.14	-42.67	13.16	-1.54	.071
20		-23.14	-38.94	13.29	-1.40	.071
22		-23.14	-39.41	13.27	-1.42	.071
23		-23.14	-38.89	13.29	-1.40	.071
25		-23.14	-39.35	13.28	-1.42	.071
26		-23.14	-39.37	13.28	-1.42	.071
28		-23.14	-38.90	13.29	-1.40	.071
30		-23.14	-38.28	13.32	-1.38	.071
31		-23.14	-37.93	13.33	-1.37	.071
33		-23.14	-41.97	13.18	-1.51	.071
36		.00	-38.41	13.31	-1.39	.071
37		-23.14	-38.32	13.31	-1.38	.071
38		-23.14	-38.36	13.31	-1.38	.071
41		.00	-38.43	13.31	-1.39	.071
42		-23.14	-38.40	13.31	-1.39	.071
45		-23.14	-38.27	13.32	-1.38	.071
46		-23.14	-38.41	13.31	-1.39	.071
48		-23.14	-38.45	13.31	-1.39	.071
51		-23.14	-38.28	13.31	-1.38	.071
52		-23.14	-38.49	13.31	-1.39	.071
57		-23.14	-38.67	13.30	-1.40	.071
59		-23.14	-38.75	13.30	-1.40	.071
61		-23.14	-38.90	13.29	-1.40	.071
63		-23.14	-38.99	13.29	-1.41	.071
65		-23.14	-38.59	13.30	-1.39	.071
67		-23.14	-38.62	13.30	-1.39	.071
69		-23.14	-38.54	13.31	-1.39	.071
71		-23.14	-38.51	13.31	-1.39	.071
73		-23.14	-38.52	13.31	-1.39	.071
78		-23.14	-38.34	13.31	-1.38	.071
82		-23.14	-39.89	13.26	-1.44	.071
83		-23.14	-38.42	13.31	-1.39	.071
84		-23.14	-38.49	13.31	-1.39	.071

Brent Run 2023 GCCS Design Plan

88	-23.14	-38.47	13.31	-1.39	.071
90	-23.14	-38.55	13.31	-1.39	.071
92	-23.14	-38.57	13.30	-1.39	.071
94	-23.14	-39.13	13.28	-1.41	.071
95	-23.14	-39.15	13.28	-1.41	.071
96	-23.14	-38.60	13.30	-1.39	.071
98	-23.14	-38.58	13.30	-1.39	.071
99	-23.14	-39.34	13.28	-1.42	.071
101	-23.14	-39.35	13.28	-1.42	.071
103	-23.14	-38.32	13.31	-1.38	.071
104	-23.14	-38.33	13.31	-1.38	.071
106	-23.14	-39.73	13.26	-1.43	.071
107	-23.14	-39.48	13.27	-1.42	.071
109	-23.14	-39.50	13.27	-1.43	.071
112	-23.14	-40.07	13.25	-1.45	.071
114	-23.14	-39.64	13.27	-1.43	.071
115	-23.14	-40.49	13.24	-1.46	.071
125	-23.14	-40.14	13.25	-1.45	.071
126	-23.14	-40.85	13.22	-1.47	.071
128	-23.14	-38.89	13.29	-1.40	.071
130	-23.14	-41.52	13.20	-1.50	.071
134	-23.14	-40.84	13.22	-1.47	.071
136	-23.14	-38.58	13.30	-1.39	.071
138	-23.14	-40.73	13.23	-1.47	.071
140	-23.14	-40.80	13.22	-1.47	.071
141	-23.14	-38.43	13.31	-1.39	.071
143	-23.14	-38.41	13.31	-1.39	.071
146	-23.14	-38.35	13.31	-1.38	.071
147	-23.14	-38.52	13.31	-1.39	.071
148	-23.14	-38.61	13.30	-1.39	.071
151	-23.14	-38.97	13.29	-1.41	.071
152	-23.14	-38.35	13.31	-1.38	.071
153	-23.14	-38.75	13.30	-1.40	.071
154	-23.14	-38.88	13.29	-1.40	.071
156	-23.14	-38.52	13.31	-1.39	.071
161	-23.14	-38.46	13.31	-1.39	.071
162	-23.14	-39.14	13.28	-1.41	.071
163	-23.14	-38.31	13.31	-1.38	.071
165	-23.14	-38.34	13.31	-1.38	.071
167	-23.14	-38.39	13.31	-1.39	.071
169	-23.14	-43.06	13.14	-1.55	.071
171	-23.14	-38.32	13.31	-1.38	.071
173	-23.14	-43.08	13.14	-1.55	.071
175	-23.14	-42.00	13.18	-1.52	.071
176	-23.14	-40.39	13.24	-1.46	.071
178	-23.14	-38.49	13.31	-1.39	.071
180	-23.14	-38.39	13.31	-1.39	.071
J-10	.00	-42.75	13.15	-1.54	.071
J-100	-23.14	-39.28	13.28	-1.42	.071
J-108	-23.14	-39.36	13.28	-1.42	.071
J-110	-23.14	-39.39	13.27	-1.42	.071
J-12	-23.14	-39.80	13.26	-1.44	.071
J-121	-23.14	-40.69	13.23	-1.47	.071
J-124	.00	-39.40	13.27	-1.42	.071
J-129	.00	-40.39	13.24	-1.46	.071

Brent Run 2023 GCCS Design Plan

J-13	.00	-42.22	13.17	-1.52	.071
J-135	.00	-43.09	13.14	-1.55	.071
J-137	-23.14	-40.86	13.22	-1.47	.071
J-139	-23.14	-43.08	13.14	-1.55	.071
J-142	.00	-38.50	13.31	-1.39	.071
J-144	-23.14	-38.44	13.31	-1.39	.071
J-145	.00	-38.58	13.30	-1.39	.071
J-149	.00	-38.72	13.30	-1.40	.071
J-15	-23.14	-43.06	13.14	-1.55	.071
J-150	.00	-39.40	13.27	-1.42	.071
J-155	-23.14	-38.59	13.30	-1.39	.071
J-157	.00	-38.91	13.29	-1.40	.071
J-159	-23.14	-39.20	13.28	-1.41	.071
J-16	.00	-39.01	13.29	-1.41	.071
J-160	-23.14	-38.57	13.30	-1.39	.071
J-164	.00	-38.42	13.31	-1.39	.071
J-166	.00	-38.43	13.31	-1.39	.071
J-168	-23.14	-38.34	13.31	-1.38	.071
J-170	.00	-38.58	13.30	-1.39	.071
J-172	.00	-43.06	13.14	-1.55	.071
J-177	.00	-41.17	13.21	-1.49	.071
J-179	.00	-38.62	13.30	-1.39	.071
J-182	-23.14	-38.90	13.29	-1.40	.071
J-183	-23.14	-38.48	13.31	-1.39	.071
J-184	.00	-43.11	13.14	-1.56	.071
J-185	-23.14	-41.98	13.18	-1.51	.071
J-187	-23.14	-41.67	13.19	-1.50	.071
J-19	.00	-38.92	13.29	-1.40	.071
J-191	.00	-39.40	13.27	-1.42	.071
J-192	.00	-39.13	13.28	-1.41	.071
J-193	-23.14	-41.11	13.21	-1.48	.071
J-194	.00	-40.90	13.22	-1.48	.071
J-195	-23.14	-40.82	13.22	-1.47	.071
J-196	-23.14	-38.56	13.30	-1.39	.071
J-197	-23.14	-38.36	13.31	-1.38	.071
J-198	-23.14	-38.36	13.31	-1.38	.071
J-199	-23.14	-38.34	13.31	-1.38	.071
J-2	.00	-38.49	13.31	-1.39	.071
J-200	-23.14	-38.41	13.31	-1.39	.071
J-201	-23.14	-38.40	13.31	-1.39	.071
J-202	-23.14	-38.37	13.31	-1.38	.071
J-203	.00	-38.40	13.31	-1.39	.071
J-204	.00	-38.43	13.31	-1.39	.071
J-205	.00	-38.43	13.31	-1.39	.071
J-206	.00	-38.43	13.31	-1.39	.071
J-207	.00	-38.46	13.31	-1.39	.071
J-208	.00	-38.52	13.31	-1.39	.071
J-209	.00	-38.50	13.31	-1.39	.071
J-21	-23.14	-39.95	13.25	-1.44	.071
J-210	.00	-38.56	13.30	-1.39	.071
J-211	.00	-38.59	13.30	-1.39	.071
J-212	-23.14	-38.63	13.30	-1.39	.071
J-213	-23.14	-38.71	13.30	-1.40	.071
J-214	.00	-38.50	13.31	-1.39	.071
J-215	.00	-38.50	13.31	-1.39	.071

Brent Run 2023 GCCS Design Plan

J-216	.00	-38.48	13.31	-1.39	.071
J-217	.00	-38.52	13.31	-1.39	.071
J-218	.00	-38.56	13.30	-1.39	.071
J-225	-23.14	-38.53	13.31	-1.39	.071
J-226	-23.14	-39.36	13.28	-1.42	.071
J-227	-23.14	-39.24	13.28	-1.42	.071
J-228	.00	-39.40	13.27	-1.42	.071
J-229	-23.14	-40.80	13.22	-1.47	.071
J-230	-23.14	-40.75	13.23	-1.47	.071
J-231	-23.14	-42.16	13.17	-1.52	.071
J-232	-23.14	-42.06	13.18	-1.52	.071
J-233	-23.14	-42.01	13.18	-1.52	.071
J-234	-23.14	-41.58	13.20	-1.50	.071
J-235	-23.14	-41.53	13.20	-1.50	.071
J-236	-23.14	-40.97	13.22	-1.48	.071
J-237	-23.14	-41.14	13.21	-1.48	.071
J-238	-23.14	-40.77	13.22	-1.47	.071
J-239	-23.14	-40.41	13.24	-1.46	.071
J-24	.00	-38.69	13.30	-1.40	.071
J-240	-23.14	-40.47	13.24	-1.46	.071
J-241	-23.14	-39.91	13.26	-1.44	.071
J-242	-23.14	-39.66	13.26	-1.43	.071
J-243	-23.14	-39.40	13.27	-1.42	.071
J-244	.00	-39.42	13.27	-1.42	.071
J-245	-23.14	-38.97	13.29	-1.41	.071
J-246	-23.14	-38.82	13.30	-1.40	.071
J-247	-23.14	-38.74	13.30	-1.40	.071
J-248	-23.14	-38.65	13.30	-1.39	.071
J-249	-23.14	-38.06	13.32	-1.37	.071
J-250	-23.14	-38.36	13.31	-1.38	.071
J-251	-23.14	-38.33	13.31	-1.38	.071
J-252	-23.14	-38.42	13.31	-1.39	.071
J-253	-23.14	-38.41	13.31	-1.39	.071
J-254	-23.14	-38.34	13.31	-1.38	.071
J-255	-23.14	-38.42	13.31	-1.39	.071
J-256	-23.14	-38.45	13.31	-1.39	.071
J-257	-23.14	-38.47	13.31	-1.39	.071
J-258	-23.14	-38.62	13.30	-1.39	.071
J-259	-23.14	-38.62	13.30	-1.39	.071
J-260	-23.14	-38.62	13.30	-1.39	.071
J-262	-23.14	-38.63	13.30	-1.39	.071
J-263	-23.14	-38.59	13.30	-1.39	.071
J-264	-23.14	-38.95	13.29	-1.41	.071
J-265	-23.14	-38.51	13.31	-1.39	.071
J-266	-23.14	-38.46	13.31	-1.39	.071
J-267	-23.14	-38.47	13.31	-1.39	.071
J-268	-23.14	-38.41	13.31	-1.39	.071
J-269	-23.14	-38.48	13.31	-1.39	.071
J-27	.00	-39.40	13.27	-1.42	.071
J-270	-23.14	-38.39	13.31	-1.39	.071
J-271	-23.14	-38.34	13.31	-1.38	.071
J-273	-23.14	-38.50	13.31	-1.39	.071
J-274	-23.14	-38.49	13.31	-1.39	.071
J-275	-23.14	-38.93	13.29	-1.40	.071
J-276	-23.14	-38.82	13.30	-1.40	.071

Brent Run 2023 GCCS Design Plan

J-277	-23.14	-38.77	13.30	-1.40	.071
J-278	-23.14	-39.37	13.28	-1.42	.071
J-279	-23.14	-39.13	13.28	-1.41	.071
J-280	-23.14	-39.03	13.29	-1.41	.071
J-281	-23.14	-38.98	13.29	-1.41	.071
J-282	-23.14	-42.02	13.18	-1.52	.071
J-283	-23.14	-38.54	13.31	-1.39	.071
J-284	-23.14	-38.56	13.30	-1.39	.071
J-286	-23.14	-38.86	13.29	-1.40	.071
J-29	.00	-38.46	13.31	-1.39	.071
J-3	.00	-43.35	13.13	-1.56	.071
J-32	.00	-38.53	13.31	-1.39	.071
J-34	.00	-42.05	13.18	-1.52	.071
J-35	.00	-38.42	13.31	-1.39	.071
J-39	.00	-38.42	13.31	-1.39	.071
J-40	-23.14	-38.36	13.31	-1.38	.071
J-43	.00	-38.42	13.31	-1.39	.071
J-44	-23.14	-38.28	13.31	-1.38	.071
J-47	.00	-38.43	13.31	-1.39	.071
J-49	-23.14	-38.48	13.31	-1.39	.071
J-50	-23.14	-38.31	13.31	-1.38	.071
J-53	-23.14	-38.52	13.31	-1.39	.071
J-54	.00	-39.70	13.26	-1.43	.071
J-55	.00	-38.98	13.29	-1.41	.071
J-56	.00	-38.80	13.30	-1.40	.071
J-58	-23.14	-39.54	13.27	-1.43	.071
J-6	.00	-44.04	13.11	-1.59	.071
J-60	.00	-39.01	13.29	-1.41	.071
J-62	.00	-40.35	13.24	-1.46	.071
J-64	.00	-38.62	13.30	-1.39	.071
J-66	.00	-40.87	13.22	-1.47	.071
J-68	.00	-38.62	13.30	-1.39	.071
J-70	.00	-38.53	13.31	-1.39	.071
J-75	.00	-38.70	13.30	-1.40	.071
J-76	.00	-38.65	13.30	-1.39	.071
J-77	-23.14	-38.53	13.31	-1.39	.071
J-8	.00	-39.36	13.28	-1.42	.071
J-85	.00	-38.50	13.31	-1.39	.071
J-89	-23.14	-38.51	13.31	-1.39	.071
J-9	-23.14	-39.45	13.27	-1.42	.071
J-91	.00	-38.63	13.30	-1.39	.071
J-93	-23.14	-38.43	13.31	-1.39	.071
J-97	.00	-38.78	13.30	-1.40	.071
R-1	.00	-45.00	13.07	-1.62	.071

* This designates the use of default density in a low pressure region

THE NET SYSTEM DEMAND (USFU) = -4165.192

SUMMARY OF INFLOWS (+) AND OUTFLOWS (-) :

NAME	FLOW (USFU)	FPN TITLE
------	-------------	-----------

Brent Run 2023 GCCS Design Plan

R-1 -4165.2

R-1

 SUMMARY OF MINIMUM.AND.MAXIMUM VELOCITIES (FT/S)

	MINIMUM		MAXIMUM
R-1	.01	P-103	33.95
P-164	.01	P-107	32.01
P-208	.09	P-6	31.07
P-26	.31	P-97	30.84
P-234	.36	P-106	28.40
P-32	.39	P-4	28.10

 SUMMARY OF MINIMUM.AND.MAXIMUM LOSS/1000. (PSI)

	MINIMUM		MAXIMUM
R-1	.00	P-155	.12
P-164	.00	P-103	.12
P-208	.00	P-107	.10
P-26	.00	P-97	.10
P-32	.00	P-101	.08
P-191	.00	P-16	.08

 SUMMARY OF MINIMUM.AND.MAXIMUM PRESSURES (USPU)

	MINIMUM		MAXIMUM
R-1	-45.00	31	-37.93
11	-44.42	J-249	-38.06
J-6	-44.04	45	-38.27
14	-44.03	30	-38.28
J-3	-43.35	J-44	-38.28
7	-43.35	51	-38.28

APPENDIX C

DRAWINGS

APPENDIX D

SURFACE EMISSIONS MONITORING PLAN

APPENDIX E

APPROVED ALTERNATIVES TO THE NSPS AND/OR NESHAP

ALTERNATIVES TO THE NSPS UNDER § 63.1981(D)(2) OR §62.16724(D)(2)

§62.16724(d)(2) & § 63.1981(d)(2): *“The collection and control system design plan must include any alternatives to the operational standards, test methods, procedures, compliance measures, monitoring, recordkeeping or reporting provisions of §62.16716 through 62.16726 [of Subpart XXX, or §63.1957 through 63.1983 of Subpart AAAA] proposed by the owner or operator.”*

In accordance with the above cited regulations, this design plan includes SELECTED COMPLIANCE METHODS (these items are simply provided for clarification of the selected procedure) and PROPOSED ALTERNATIVES to the operational standards, test methods, procedures, compliance measures, monitoring, recordkeeping, and reporting provisions of the NSPS and NESHAP.

As allowable by Subpart OOO, the facility has “opted-in” to the major compliance provisions of Subpart AAAA. Due to this action, the facility maintains compliance by following the analogous provisions of §63.1958, 63.1960, and 63.1961 of Subpart AAAA in lieu of compliance with §62.16716, 62.16720, and 62.16722 of Subpart OOO. Accordingly, alternatives approved for the site pursuant to language included in §63.1958, 63.1960, or 63.1961 under Subpart WWW are still considered APPROVED ALTERNATIVES per §63.1955, and do not require re-approval.

§63.1955: *Before September 28, 2021, if alternatives to the operational standards, test methods, procedures, compliance measures, monitoring, recordkeeping, or reporting provisions have already been approved under 40 CFR part 60, subpart WWW; subpart XXX; a federal plan; or an EPA- approved and effective state or tribal plan, these alternatives can be used to comply with this subpart, except that all affected sources must comply with the SSM requirements in subpart A of this part as specified in Table 1 of this subpart and all affected sources must submit compliance reports every 6 months as specified in §63.1981(h), including information on all deviations that occurred during the 6-month reporting period.*

APPROVED ALTERNATIVES

E.1 Positive Pressure

§63.1958(b)(3): “Operate the collection system with negative pressure at each wellhead except under the following conditions: Use of a geomembrane liner or synthetic cover... The owner or operator shall develop acceptable limits in the design plan.”

As referenced, extraction wells located in portions of the disposal area which are overlain by a geomembrane or synthetic cover, i.e., the closed portions of the Landfill, may be operated under positive pressure. This variance requires the demonstration of acceptable pressure limits within the Design Plan. The pressure limits below were included in the prior GCCS Design Plan for Brent Run, which was submitted in 2004 and approved in 2006.

All wells under the geomembrane final cover system are designed to lay under six (6) inches of topsoil, two (2) feet of compacted clay, and a synthetic geomembrane. The maximum allowable pressure at the wellhead before uplift of the synthetic cover system will occur is 58" of water column (WC). Calculations and supporting reference material used in the determination of the maximum allowable pressure is included in **Appendix F**. Based on these calculations, the acceptable operating pressure at landfill gas extraction wells under the geomembrane final cover system can be conservatively set at + 19" of WC. This reflects a factor of safety in excess of 3.

Since the final cap system design is the same for the entire facility, this demonstration applies to any area under a geomembrane. Currently gas extraction wells in Cells 1, 2, and 3 are under final cover, which includes active collection wells designated BRLF01 - 05, 07 - 12, 16 - 23, 27, 32, 35, 37, 38, 40, 43, 49, 51, 59, 62, 63, and 67 – 71. Brent Run Landfill will notify EGLE when new sections of the landfill reach final grade, and the final cap system is installed.

Reference Document: Approval Letter for 2004 Brent Run Landfill GCCS Design Plan

E.2 Demonstration for Temperature Higher Operating Values (HOV)

To establish an HOV for a collector, the landfill must submit a demonstration to EGLE for approval. NESHAP identifies the criteria for an HOV:

§63.1958(c): Operate each interior wellhead in the collection system with a landfill gas temperature less than...131 degrees Fahrenheit before September 27, 2021 and 145 degrees Fahrenheit on/after September 27, 2021. The owner or operator may establish a higher operating temperature value at a particular well. A higher operating value demonstration must be submitted to the Administrator for approval and must include supporting data demonstrating that the elevated parameter neither causes fires nor significantly inhibits anaerobic decomposition by killing methanogens. The demonstration must satisfy both criteria in order to be approved (i.e., neither causing fires nor killing methanogens is acceptable).

EGLE (formerly MDEQ) has approved the HOVs listed in Table E.2 for wells located at Brent Run Landfill under analogous provision §60.753 of Subpart WWW. Brent Run Landfill may request additional HOVs if deemed appropriate by future wellfield conditions.

Table E.2: Approved Temperature HOVs

Well ID	Temperature HOV	Date Approved
BRLF0115	140.00	8/17/2018
BRLFHC04	145.00	1/3/2018

Reference Document: January and August 2018 MDEQ Approval Letters

SELECTED COMPLIANCE METHODS

E.3 Other Collectors – Optional GCCS connections

Brent Run Landfill may choose to connect other points within and around the facility to the GCCS in order to implement “best management practices” for collection of LFG. These “other collectors” (leachate cleanout risers, Leachate sump risers, etc.) will be connected to the GCCS voluntarily and can be disconnected at any time provided they are “sealed” with a cap. This design plan contains no provisions for collecting gas from these other collection points. The vertical gas extraction well layout is sufficient to accomplish collection in accordance with NSPS and/or NESHAP.

A list of wells connected to the GCCS voluntarily are listed in Table E.3. However, Brent Run Landfill may choose to connect “other collector” points as they deem appropriate. When connected, Brent Run Landfill understands that any “other collector” which is within or adjacent to the waste itself would be required to meet the operational requirements of 40 CFR §63.1958, and will keep records of monitoring and any additional compliance activities performed pursuant to the rule. If the point cannot meet these requirements, Brent Run Landfill will disconnect them from the GCCS, again as the facility deems appropriate. In the event that Brent Run Landfill wishes to continue collection from an “other collector” even while it exhibits exceedances with 40 CFR §63.1958, Brent Run Landfill will request an alternative operating procedure based upon the “other collector” monitoring data.

Table E.3: Optional GCCS Connections

Well ID	Alternate Oxygen Standard*	Date Approved*
BRLCEL10	21.90	8/7/2013
BRCEL10B	21.90	11/6/2017
BRCEL10S	21.90	11/6/2017
BRLFCEL8	21.90	11/6/2017
BRLFCEL9	21.90	11/6/2017

*These wells were approved to operate up to ambient oxygen levels by EGLE under Subpart WWW as optional connections due to their intended function. However, as §63.1958 does not contain an oxygen standard, the operation of any well at elevated oxygen levels no longer requires Administrator approval.

Reference Document: USEPA Letter to Livingston Landfill

E.4 Well Decommissionion

§63.1958(b)(3): *“Operate the collection system with negative pressure at each wellhead except under the following conditions: . . . A decommissioned well. A well may experience a static positive pressure after shut down to accommodate for declining flows. All design changes shall be approved by the Administrator.”*

Brent Run Landfill recognizes that the above regulation is self-implementing and has been clearly approved by the USEPA in past correspondence. Brent Run Landfill will utilize the following standard operating procedure for decommissioned wells:

- At wells exhibiting declining flows where the resulting LFG quality is considered detrimental to the health of the wellfield, the location will be shut off from the GCCS, but may be “recommissioned” if gas quality recovers.
- The monthly monitoring required by §63.1960 will be conducted for all wells that have been shut down, but monitored positive pressure will not be considered an exceedance of the operating limits in §63.1958.
- If monthly monitoring indicates that pressure has built up in a well shut off from the GCCS, the well will be connected temporarily to relieve the pressure during the monitoring event.
- The quarterly surface emissions monitoring (SEM) required under 40 CFR §63.1960 will be conducted in areas that contain wells that have been shut down. Standard remediation steps, including evaluating the need to return wells to full-time service, will be followed if exceedances of the 500 ppm methane surface concentration limit are detected.
- Although the decommissioning of wells to compensate for declining flows is allowable without prior administrator approval, Brent Run Landfill will notify EGLE semi-annually as part of the NSPS and NESHAP semi-annual reporting. The report will contain a current list of all wells which are decommissioned (*vacuum valve is closed, and the well may have positive pressure*), in addition to monthly well monitoring and SEM results.

Reference Document: USEPA Letter to Akron Regional Landfill

E.5 Monitoring of Wells Installed Prior to 2-Year/5-Year Rule

§63.1960(C)(5)(b): *For purposes of compliance with §63.1958(a), each owner or operator of a controlled landfill must place each well or design component as specified in the approved design plan as provided in §63.1981(b). Each well must be installed no later than 60 days after the date on which the initial solid waste has been in place for a period of: (1) Five (5) years or more if active; or (2) Two (2) years or more if closed or at final grade.*

There will be occasions when Brent Run Landfill will decide to install extraction wells included in the design plan prior to the onset of NSPS and/or NESHAP requirements. Based on the foregoing regulatory citation, any extraction wells installed prior to the requirements of the NSPS and/or NESHAP will not be subject to the operational and/or recordkeeping requirements of NSPS and/or NESHAP until the age of the initial waste placed reaches 5 years old if in an active area or 2 years old if closed or at final grade. To make certain that the EGLE is made fully aware of these special circumstances, Brent Run Landfill will maintain records indicating the date of initial extraction well installation and the regulatory compliance date of any “early extraction well”. These wells will generally be operated in accordance with NESHAP operational standards for pressure and temperature; however, they are NOT subject to the NESHAP until the waste age meets the rule-based criteria and are not required to be reported.

Reference Document: USEPA/ADI Control numbers 0800012 and 0600062

E.6 NESHAP Enhanced Monitoring

§63.1961(a)(5): *“...you must initiate enhanced monitoring at each well with a measurement of landfill gas temperature greater than 62.8 degrees Celsius (145 degrees Fahrenheit) as follows...(vii) The enhanced monitoring [in] this paragraph (a)(5) must begin 7 days after the first measurement of landfill gas temperature greater than 62.8 degrees Celsius (145 degrees Fahrenheit)...”*

The preamble to the NESHAP (FRL-10006-05-OAR) includes the following statements clarifying the enhanced monitoring schedule:

“Enhanced monitoring begins 7 days after the first temperature reading exceeding 145°F is recorded and continues until the measured wellhead operating temperature is 145°F or less, or an HOV is approved.”

“Furthermore, the concern that the enhanced monitoring requirements would continue in perpetuity is unsubstantiated. First, landfills have up to 7 days to adjust the well to achieve a lower temperature before the enhanced monitoring requirements are triggered (40 CFR 63.1961(a)(5)(vii)). Second, the enhanced monitoring can stop once the well temperature drops back to 145°F or less.”

Brent Run Landfill interprets these statements to allow the facility to initiate enhanced monitoring within 7 days of the initial measurement, unless the corrective actions taken within the first 7 days reduce the well temperature to 145°F or less. Brent Run Landfill will continue enhanced monitoring until either an HOV is obtained for the well which sets a standard higher than the current operating temperature, or until the well temperature drops back to 145°F or less.

E.7 NESHAP Down-Well Monitoring

§63.1961(a)(6): *“For each wellhead with a measurement of landfill gas temperature greater than or equal to 73.9 degrees Celsius (165 degrees Fahrenheit), annually monitor temperature of the landfill gas every 10 vertical feet of the well...”*

Based on the facility’s understanding of this provision and the preceding §63.1961(a)(5), the following provisions will apply for down-well monitoring:

- The monitoring will be performed at least once at any time before the end of the calendar year following the first temperature measurement greater than 165°F.
- The well will be shut off, and the wellhead removed, in order to perform down well monitoring. Based on experience at other sites, down-well temperatures recorded while the well is operating are not representative due to heat transfer and mixing that occurs during gas extraction. Shutting off the well prior to monitoring also reduces risk to the technician performing the monitoring. Additional measures to ensure the technician’s safety will also be implemented as needed.
- If conditions (temperature, gas quality, carbon monoxide, visual indicators, etc.) at the wellhead suggest that a subsurface fire is occurring, the well will be shut off in accordance with §63.1958(b)(1). To prevent potential oxygen intrusion and unnecessary risk to personnel, the wellhead will not be removed, and down-well temperature will not be measured, until data

indicate the subsurface fire is no longer occurring. In these cases, the status of the affected well will be reported in the semi-annual report in accordance with §63.1981(h)(8).

- If there are no indications of a subsurface fire, the liquid level in the well will be measured prior to temperature monitoring. To minimize the potential for damage to the temperature monitoring probe, the down-well temperature monitoring will terminate above the liquid level.

PROPOSED ALTERNATIVES

E.8 Well Abandonment

If a well is decommissioned in accordance with the procedures presented in section E.4 above, and Brent Run Landfill provides data to EGLE that is certified by a professional engineer indicating four (4) consecutive quarters of clean SEM events, Brent Run Landfill will abandon (cut, cap, and bury) the extraction well. This information will be included in an abandonment notification submitted to EGLE as well as in the Semi-annual reports required by NSPS and NESHAP. Once abandoned, the well will no longer be required to be monitored monthly per NSPS XXX and/or NESHAP AAAA.

Reference Document: USEPA Letter to Akron Regional Landfill

E.9 Expansion of the Collection System

“Expansion” of the collection system has not been defined in NSPS or NESHAP. Brent Run Landfill wishes to define “expansion” as directly relating to the term “sufficient density”. The GCCS is designed to meet the definition of “sufficient density” as described in the GCCS Design Plan.

There are many potential methods for “expanding” the gas collection system. In the event that the need for “expansion” is triggered by some operational exceedance contained in §63.1958, Brent Run Landfill wishes to use the below definition for “expansion” for the purposes of this design plan. In order to meet this definition, solutions to any collection system/extraction well exceedance may include enhancements to the GCCS other than the installation of additional well(s). These enhancements could include one or more of the following measures:

- Installation/upgrades to the blower/flare skid equipment (bigger blowers, larger flare, additional blowers, etc.);
- Repair of collection system lateral piping to return vacuum back to the collector;
- Installation of a liquid management system in the extraction wells or sumps;
- Installation/modification of other ancillary equipment (larger air compressor, additional air, and condensate force main lines, etc.);
- Re-drilling replacement wells;

- Drilling additional wells;
- Installation of additional/replacement horizontal gas collectors;
- Repair of landfill cap to lessen the chance of encountering ambient air;
- Repair/Replace header valves; and
- Additional well field tuning and troubleshooting which will return collection efficiency to a state where “sufficient density” is met.

Please note that the foregoing list is not intended to be exhaustive. Any enhancements made to the existing GCCS will be documented in the Semi-Annual Reports prepared for compliance with NSPS/NESHAP requirements. Please note that Brent Run Landfill will/can proactively implement many of these measures expeditiously to make certain that exceedances are addressed well within the 120-day period before an exceedance triggers an expansion requirement. In the event that “sufficient density” cannot be met during the 120-day period, Brent Run Landfill will prepare an alternative compliance schedule based on the requirements of NESHAP or review and approval by EGLE.

Reference Document: NSPS regulations and EPA-453/R-94-021 – “Air Emissions From Municipal Solid Waste Landfills – Background Information For Final Standards And Guidelines”.
<http://www.epa.gov/ttnatw01/landfill/landflpg.html>

E.10 Monitoring of Wells that are Raised/In Active Areas

During the process of refuse filling operations, periodically, vertical collection devices (vertical wells) have to be “raised” so the new refuse is not placed over the top of an existing vertical well in a manner that covers the well with refuse and therefore prevents access to the well. Wells are raised in advance of a new lift of refuse, typically between 10 – 30 feet. Therefore, wells may be at a height 10 - 30 feet above grade, in anticipation of the new refuse, during the monthly wellfield monitoring event. Furthermore, after the well is raised and the waste is being filled around the well, the area is dangerous and poses significant safety concerns for a field technician attempting to perform the monthly wellfield monitoring. The time it takes to complete the construction and waste placement activities around the well will vary, but will typically not last more than two months. Therefore, due to the dangers associated with well raising and the subsequent waste placement, Brent Run Landfill requests that raised wells be exempt from the monthly NSPS monitoring for a period not greater than 60 days. It is the understanding of Brent Run Landfill that the cessation of monitoring specific wells due to various

unsafe conditions, such as at raised wells, may be requested, and approved as alternatives to the operating standard.

To provide another state's regulations/authorized methods regarding this alternative request, California's Bay Area Air Quality Management District (BAAQMD) has regulations which are written specifically to address this issue. The BAAQMD Regulation 8, Rule 34, Condition 116 allows for the temporary exemption of monthly wellhead monitoring (pressure, temperature, and oxygen) for wells that are raised provided all of the following conditions are met:

- New fill is being added,
- No more than 5 gas collection wells or 10% of the gas collection wells which contribute to designed GCCS density), whichever number is less, are shut down at any time for well raising purposes,
- A gas collection well is not disconnected from a vacuum source for longer than 24 consecutive hours unless fill is actively being placed or compacted in the immediate area,
- Once installed, a gas collection well extension is sealed or capped until the raised well is reconnected to a vacuum source, and
- Well disconnection times are recorded.

As shown above, there are different ways to approach this necessary alternative. Brent Run Landfill is simply suggesting a record be kept including the last date the well was monitored and the date the newly raised well was first monitored. The size of Brent Run Landfill's working face will by itself limit the number of wells that would be impacted by this at any one time.

Reference Document: USEPA/ADI Control number 0900059

E.11 Surface Emissions Monitoring – Dangerous Areas Exemption

According to ADI 0800010, the Three Rivers Landfill's RDF, submitted March 15, 2007, requested a waiver for the quarterly methane surface concentration monitoring for roads, active areas, truck traffic areas and areas with slopes greater than 3:1 under the analogous 40 CFR Part 60, Subpart WWW regulation. The response issued by the EPA waived "the monitoring for roads, but not for the other

areas covered by the request under NSPS subpart WWW. Based upon previous EPA determinations, surface methane monitoring requirements cannot be waived for “active areas, truck traffic areas, or areas with slopes less than 4:1.”

Brent Run Landfill believes this statement does not provide enough guidance for those who operate at the field level to make determinations on the day of sampling on how to complete the required work while maintaining a safe working environment. Unsafe and dangerous areas should be evaluated on a site-specific basis. Each facility may have its own unique set of circumstances and safety issues. For example, a facility which receives 10,000 tons of waste per day and operates five “tippers” has different concerns than a facility which receives 500 tons of waste per day via smaller waste transport vehicles.

The operational standard in §63.1958(d) states: “Areas with steep slopes or other dangerous areas may be excluded from the surface testing”. There are other areas at an active landfill, in addition to steep slopes and roads, which are dangerous and should be exempted from surface emissions monitoring.

The working face includes the turnaround/staging areas for trucks/equipment/waste tipping operations and is also considered a dangerous area for completing scans. Visibility and proximity issues create situations where someone who is in the area performing scans may encounter hazards such as flying debris (caught in or pushed out by equipment tracks, blades, or vehicle tires), breathing hazards (dust from waste loads), and crushing hazards (being in a blind spot for equipment and vehicles or wastes being offloaded). Brent Run Landfill will not monitor the working face area of the landfill during its routine surface scans.

Additionally, considering that the waste is newly placed waste where anaerobic decomposition has not commenced it would be unreasonable to do so.

Roads, truck traffic, and active construction which occur in areas required to be monitored in accordance with 40 CFR §60.765(c) are also considered unsafe and dangerous. Roads which intersect or traverse along the designated 30-meter scan route shall be excluded from the scan based on the safety exemption. Active construction areas may include, but not be limited to, the following activities:

- Capping or closure activities
- Landfill Gas (LFG) Well Drilling
- LFG collection piping construction

- Cover repair, maintenance, or installation

Performing surface scans within these types of active construction areas is unsafe and dangerous for many of the same reasons as the active working face. The hazards include equipment such as bulldozers, loaders, rollers (compaction equipment), articulating dump trucks, drill rigs, excavators, etc. which are typically operating in these construction areas.

There is also the same risk of working down slope from construction areas. Some additional hazards such as: runaway rolls of geosynthetics, soil clods, rocks, and even equipment rolling down slope present extreme hazards to anyone walking in or below active construction areas. As in the case of the working face, construction activities are temporary activities which would result in an unsafe area.

Brent Run Landfill believes there may be additional areas, not mentioned above, that are dangerous at times depending on the current site-specific conditions. Therefore, Brent Run Landfill expects a properly trained field technician performing the surface emissions monitoring to determine unsafe and dangerous areas at the time of monitoring and these areas be exempt from monitoring during the current monitoring event only. The field technician will document site conditions which predicated the determination to exclude specific areas during each monitoring event as additional recordkeeping efforts. The intention of Brent Run Landfill is not to be exempt from performing surface emissions monitoring, but to provide each on-site personnel a safe working environment, per the General Duties clause of the OSHA Act of 1970.

Reference Document: USEPA/ADI Control numbers 0800010

E.12 Additional Alternatives

Brent Run Landfill may request additional Alternatives to the NSPS and/or NESHAP from the USEPA under a site- specific determination request. Alternatives that are requested and subsequently approved by the USEPA will be submitted to EGLE as an amendment to this GCCS Design Plan.

APPENDIX F

REFERENCE DOCUMENTS FOR APPROVED ALTERNATIVES TO THE NSPS AND/OR NESHAP

**E.1 - APPROVAL LETTER FOR 2004 BRENT RUN LANDFILL GCCS
DESIGN PLAN**



STATE OF MICHIGAN
DEPARTMENT OF ENVIRONMENTAL QUALITY
LANSING DISTRICT OFFICE



JENNIFER M. GRANHOLM
GOVERNOR

STEVEN E. CHESTER
DIRECTOR

February 13, 2006

Mr. Brian J. Ezyk
Republic Services of Michigan
P.O. Box 634
New Boston, MI 48164

Dear Mr. Ezyk:

SUBJECT: Gas Collection and Control System Design Plan
Brent Run Landfill, 8247 Vienna Road (M-57), Montrose

This letter is in regard to the submittal on May 14, 2004, of the May 2004 revision of the Gas Collection and Control System Design Plan for the Brent Run Landfill.

Recently, a review of the plan by Air Quality Division (AQD) and the Waste and Hazardous Materials Division (WHMD) was completed. The result of the review indicates that the Gas Collection and Control System Design Plan submitted on May 14, 2004, met the minimum requirements of the AQD and WHMD review procedure and is approved.

If you have any questions regarding this matter, please contact me.

Sincerely,

Kenneth L. Damrel
Sr. Environmental Engineer
Air Quality Division
517-335-6305

KLD:TG

**BRENT RUN LANDFILL
MONTROSE, MICHIGAN**

**LANDFILL GAS COLLECTION
AND CONTROL SYSTEM
DESIGN PLAN**

Prepared for

Republic Services of Michigan III, LLC

May 2004

Prepared by

EMCON/OWT, Inc.
14155 Farmington Road
Livonia, Michigan 48154
(734) 524-9610

Project 102421

On February 9, 2001, EMCON conducted Tier 2 and Tier 3 testing at the Brent Run Landfill. Based on the Tier 2 and Tier 3 NSPS method for estimating the potential maximum NMOC emission rate, the Brent Run Landfill did not exceed the 50 Mg/yr threshold. On May 10, 2001, Republic submitted to the Michigan Department of Environmental Quality (MDEQ) an NSPS applicability determination request, requesting acceptance of the Tier 2 and Tier 3 results. A similar request was submitted to the USEPA Region 5 on December 10, 2001. However, the USEPA concluded that the test results could not be accepted beyond the NSPS final compliance deadline of December 10, 1998. Therefore, Brent Run Landfill is required to comply with section §60.752(b)(2) of the NSPS.

4.6.1 Submit a Design Plan

§60.752(b)(2)(i) Submit a collection and control system design plan prepared by a professional engineer to the Administrator within 1 year:

On behalf of Republic, EMCON has prepared this GCCS design plan to update and replace the existing GCCS design plan prepared in June 1997 by Conestoga-Rovers and Associates. Republic is submitting this design plan to the MDEQ, with a copy sent to the USEPA Region 5 office for approval, consistent with NSPS requirements.

4.6.2 Alternatives to the NSPS

§60.752(b)(2)(i)(B) The collection and control system design plan shall include any alternatives to the operational standards, test methods, procedures, compliance measures, monitoring, record keeping or reporting provisions of §60.753 through §60.758 proposed by the owner or operator.

On September 13, 2001, EMCON, on behalf of Republic, submitted a request to the MDEQ to establish a higher operating oxygen concentration of 20% for LFG Well #10 at the Brent Run Landfill. Based on well readings, surface emissions monitoring, and well and landfill cover integrity inspections, Well #10 did not demonstrate any signs of negative impacts to the landfill, such as potentially causing fires or significantly inhibiting anaerobic decomposition, as required by section §60.753(c) of the NSPS. On January 16, 2002, MDEQ approved the request of a higher operating oxygen concentration of 20% for LFG Well #10. A copy of the MDEQ approval letter is provided in Appendix F.

Section 60.753(b)(2) of the New Source Performance Standards (NSPS), being 40 CFR Part 60 Subpart WWW, states that the permittee (landfill owner/operator) "operate the collection system with negative pressure except under the following conditions: Use of a geomembrane or synthetic cover. The owner or operator shall develop acceptable pressure limits in the design plan."

All wells under the geomembrane final cover system are under six (6) inches of topsoil, two (2) feet of compacted clay, and a synthetic geomembrane. Based on calculations performed by EMCON, and as-built information, landfill gas extraction wells under a geomembrane final cover system may be operated with positive pressure pursuant to Section 60.753(b)(2). The maximum allowable pressure at the wellhead before uplift of the synthetic cover system will occur is 58" of water column (WC). Calculations and supporting reference material used in the determination of the maximum allowable pressure is included in Appendix F. Based on these calculations, EMCON estimates that the acceptable operating pressure at landfill gas extraction wells under the geomembrane final cover system can be conservatively set at +19" of WC. This reflects a factor of safety in excess of 3.

Currently gas extraction wells 1, 2, 3, 4, 5, 6, 9, 10, 14, 16, 17, 19, 20, 21, 22, 23, and 35 are under final cover. Since the final cap system is the same for the entire facility, this demonstration applies to any area under a geomembrane. Brent Run Landfill will notify MDEQ when a gas extraction well can be operated under positive pressure as the landfill reaches final grade and the final cap system is installed.

4.6.3 Specifications for Active Collection Systems

As stated in Sections 4.1 through 4.5 of this design plan, the GCCS proposed at the Brent Run Landfill complies with the specifications for active collection systems as stipulated in §60.759 of the NSPS. If future expansions of the GCCS are necessary, they will be designed to comply with the NSPS requirements or any approved alternatives.

4.6.4 Install a Landfill Gas Collection and Control System

§60.752(b)(2)(ii) Install a collection and control system that captures the gas generated within the landfill as required by paragraphs (b)(2)(ii)(A) or (B) and (b)(2)(iii) of this section within 30 months after the first annual report in which the emission rate equals or exceeds 50 megagrams per year, unless Tier 2 or Tier 3 sampling demonstrates that the emission rate is less than 50 megagrams per year, as specified in §60.757(c)(1) or (2).

§60.752(b)(2)(ii)(A)(2) Collect gas from each area, cell, or group of cells in the landfill in which the initial solid waste has been placed for a period of:

§60.752(b)(2)(ii)(A)(2)(i) 5 years or more if active; or

§60.752(b)(2)(ii)(A)(2)(ii) 2 years or more if closed or at final grade.

The GCCS will be constructed within the prescribed schedule under §60.752(b)(2)(ii). Future expansions to the GCCS will proceed in accordance with the schedules under paragraphs (i) and (ii) of this section.

APPENDIX F
ALTERNATIVE OPERATING PARAMETER DOCUMENTATION

BRENT RUN LANDFILL
Genesee County, Michigan
Geomembrane Uplift Resistance Calculations

Well Number	Cover Thickness (ft)	Soil Density (pcf)	Soil Load (psf)	Uplift Resistance (psi)	Uplift Resistance (inches of WC)	Factor of Safety	Allowable Positive Pressure (inches of WC)
1	2.5	121.2	303	2.1	58	3.00	19
2	2.5	121.2	303	2.1	58	3.00	19
3	2.5	121.2	303	2.1	58	3.00	19
4	2.5	121.2	303	2.1	58	3.00	19
5	2.5	121.2	303	2.1	58	3.00	19
6	2.5	121.2	303	2.1	58	3.00	19
9	2.5	121.2	303	2.1	58	3.00	19
10	2.5	121.2	303	2.1	58	3.00	19
14	2.5	121.2	303	2.1	58	3.00	19
16	2.5	121.2	303	2.1	58	3.00	19
17	2.5	121.2	303	2.1	58	3.00	19
19	2.5	121.2	303	2.1	58	3.00	19
20	2.5	121.2	303	2.1	58	3.00	19
21	2.5	121.2	303	2.1	58	3.00	19
22	2.5	121.2	303	2.1	58	3.00	19
23	2.5	121.2	303	2.1	58	3.00	19
35	2.5	121.2	303	2.1	58	3.00	19

* Soil Density and cover thickness values obtained from the Construction Documentation Report 1999 Final Closure

Sample Calculations: Well #5

Cover Thickness = 2.5 ft

Soil Density = 121.2 pcf

Load on Geomembrane = 2.5 ft * 121.2 pcf = 303 psf

Uplift Resistance in psi = Load / (144 psf / psi) = 303 psf / 144 (psf/psi)

Unit weight of water = 62.4 pcf

1 psi = 144 psf = 144 psf / 62.4 pcf = 2.31 feet of water column = 27.7 inches of water column

Uplift Resistance (inches of water column) = psi * 27.7 inches of water column/ psi

E.2 - JANUARY AND AUGUST 2018 MDEQ APPROVAL LETTERS

From: Luplow, Michelle (DEQ) <LuplowM1@michigan.gov>
Sent: Wednesday, January 3, 2018 7:38 AM
To: Boudreau, Matt
Cc: Tim Church; Mahmood, Khaled; pete.campbell@landfillgasom.com; Joe Chalker
Subject: RE: Brent Run - Wellfield Matrix - ACT / HOV Request for Wells GW-75 and HC04
Attachments: BRL Wellfield Matrix 2017 12-26-17.xls

Matt,
Attached is the Wellfield Matrix with my approvals for each request.

Thank you,
Michelle

Michelle Luplow, MPH
Environmental Quality Analyst, MDEQ Air Quality Division
517-284-6636

Lansing District Office
Constitution Hall, First Floor South
525 W. Allegan
P.O. Box 30242
Lansing, MI 48909

From: Boudreau, Matt [mailto:Matt.Boudreau@Cornerstoneeg.com]
Sent: Tuesday, December 26, 2017 11:55 AM
To: Luplow, Michelle (DEQ) <LuplowM1@michigan.gov>
Cc: Tim Church <TimC@WasteConnections.com>; Mahmood, Khaled <Khaled.Mahmood@Cornerstoneeg.com>;
pete.campbell@landfillgasom.com; Joe Chalker <joe.chalker@landfillgasom.com>
Subject: Brent Run - Wellfield Matrix - ACT / HOV Request for Wells GW-75 and HC04

Michelle,

Please find attached an Alternate Compliance Timeline (ACT) and Higher Operating Value (HOV) for wells BRLF0075 and BRLFHC04 and the associated rolling wellfield data for these wells. These wells have exhibited elevated concentrations of Oxygen (BRLF0075) or elevated Temperature (BRLFHC04) approaching 15 days. Let us know if you have any comments or questions concerning the attached request and data.

Thank you,

Matt Boudreau
Project Manager

Oct-17	Nov-17	Dec-17	Well ID	BRL Comments/Request 12/26/2017	MDEQ Response 1/3/2018
Temperature					
		BRLFHC04	BRLFHC04	<p>During the monthly monitoring for December performed on December 12, 2017 horizontal landfill gas collector BRLFHC04 exhibited elevated temperatures above 131 degrees F. Adjustments were made to the wellhead in an attempt to correct the temperature exceedance and re-monitoring was performed immediately and again on December 23, 2017. However, these tuning events failed to bring the temperatures within the well below 131 degrees F. The wellhead was inspected for potential air intrusion and signs of soot or smoke. No leaks were detected and no signs of soot or smoke where indicated during this inspection.</p> <p>An additional Carbon Monoxide (CO) monitoring was performed with a Draeger stain tube which indicated a CO concentration of 0 ppm was present within the landfill gas at this well location. Additionally the landfill gas monitoring data (attached) shows methane concentrations ranging from 45 - 55 percent methane. These monitoring results indicate that the increased temperatures observed within this well are not causing a fire or significantly inhibiting anaerobic decomposition by killing methanogens.</p> <p>Therefore, BRL requests a Higher Operating Temperature of 145 degrees F at this well location. Additionally, BRL requests an alternate compliance timeline of March 12, 2018 (90 days from initial exceedance) to allow time beyond 15 days for the approval of this HOV.</p>	<p>Higher Temperature Operating Value of 145 degrees approved for this well, with the caveat that methane concentrations will be consistent with the 45-55% range specified in the request.</p>

From: Luplow, Michelle (DEQ) <LuplowM1@michigan.gov>
Sent: Friday, August 17, 2018 7:23 AM
To: Carmack, Doug
Cc: Timothy.Church@WasteConnections.com; Mahmood, Khaled; Boudreau, Matt; Pete Campbell
Subject: RE: Brent Run - Wellfield Matrix - HOV Request
Attachments: BRL Wellfield Matrix 2018 7-27-18.xls

Categories: Blue Category

Doug,

Attached is the HOV approval. Thank you for the additional information to correlate past HOV approvals to this one.

From: Carmack, Doug <Doug.Carmack@cornerstoneeg.com>
Sent: Monday, July 30, 2018 10:11 AM
To: Luplow, Michelle (DEQ) <LuplowM1@michigan.gov>
Cc: Timothy.Church@WasteConnections.com; Mahmood, Khaled <Khaled.Mahmood@Cornerstoneeg.com>; Boudreau, Matt <Matt.Boudreau@Cornerstoneeg.com>; Pete Campbell <Pete.Campbell@landfillgasom.com>
Subject: Brent Run - Wellfield Matrix - HOV Request
Importance: High

Michelle,

Please find attached updated information on the Alternate Compliance Timeline (ACT) requested on May 15, 2018, as well as an HOV request for temperature of 140 degrees for well BRLF0115. Please contact us with any questions or comments you may have.

Thanks,

Doug Carmack
Environmental Scientist



39395 West Twelve Mile Road, Suite 103, Farmington Hills, MI 48331
P: 630.410.7210 | **M:** 586.846.6385 | **F:** 248.994.5456 | [Follow us on LinkedIn!](#)
Doug.Carmack@CornerstoneEG.com
www.CornerstoneEG.com

Brent Run Landfill Field Matrix - 2018

May-18	Jun-18	Jul-18	Well ID	BRL Comments/Request 5/15/2018	MDEQ Response 5/21/2018	BRL Comments/Request 7/30/2018	MDEQ Response 8/17/18
Oxygen						No Oxygen exceedances being tracked at this time. All wells showing pressures within NSPS parameters or approved alternates.	
Pressure						No Pressure exceedances being tracked at this time. All wells showing pressures within NSPS parameters or approved alternates.	
Temperature							
BRLF0115	BRLF0115	BRLF0115	BRLF0115	<p>BRLF0115 displayed elevated temperature on May 1, 2018. This is a new well and was started-up on April 13, 2018. Investigations are currently being performed to determine the cause of the elevated temperature. No smoke or soot was observed at the wellhead during tuning events and it is not believed that the elevated temperatures are causing a fire within the landfill. Additional time is needed to stabilize the monitored parameters. Therefore, BRL requests an Alternate Compliance Timeline of 90 days (07/30/18) from the original exceedance date to further investigate the cause and determine if an Higher Operating Value (HOV) is appropriate.</p>	<p>An ACT request of 7/30/18 is approved for further investigation on the cause of the temperature exceedance at BRLF0115. 5/21/18 ML</p>	<p>During the monthly monitoring for May performed on May 1, 2018 landfill gas collector BRLF0115 exhibited elevated temperatures above 131 degrees F. Adjustments were made to the wellhead in an attempt to correct the temperature exceedance and re-monitoring was performed immediately and again on May 14, 2017. However, these tuning events failed to bring the temperatures within the well below 131 degrees F. The wellhead was inspected for potential air intrusion and signs of soot or smoke. No leaks were detected and no signs of soot or smoke where indicated during this inspection.</p> <p>An additional Carbon Monoxide (CO) monitoring was performed with a Draeger stain tube which indicated a CO concentration of <20 ppm was present within the landfill gas at this well location. Additionally the landfill gas monitoring data (attached) shows methane concentrations ranging from 36 - 43 percent methane. These monitoring results indicate that the increased temperatures observed within this well are not causing a fire or significantly inhibiting anaerobic decomposition by killing methanogens.</p> <p>Therefore, BRL requests a Higher Operating Temperature of 140 degrees F at this well location.</p>	<p>AQD received HOV request via email 7/30/18. HOV of 140F approved for BRLF0115; if at any time this well is operated between the permitted 131F and the HOV of 140F and there are indications that methanogens are being killed and/or that there are indicators of a fire, the HOV of 140F must be reconsidered. ML</p>
Other							
						No Other issues currently being tracked at this time.	

E.3 USEPA LETTER TO LIVINGSTON LANDFILL



UNITED STATES ENVIRONMENTAL PROTECTION AGENCY
REGION 5
77 WEST JACKSON BOULEVARD
CHICAGO, IL 60604-3590

DEC 28 2015

REPLY TO THE ATTENTION OF:

CERTIFIED MAIL
RETURN RECEIPT REQUESTED

Eric Dippon
Environmental Manager
American Disposal Services of Illinois, Inc.
Livingston Landfill
14206 E 2100 N. Road
Pontiac, Illinois 61764

RE: Livingston Landfill
Leachate Cleanout Risers

Dear Mr. Dippon:

Thank you for your letter dated September 30, 2015 to the U.S. Environmental Protection Agency requesting approval of an alternative operating procedure in accordance with 40 C.F.R. § 60.753(c) at the Livingston Landfill located in Pontiac, Illinois. The Livingston Landfill is subject to the New Source Performance Standards (NSPS) for Municipal Solid Waste Landfills (40 C.F.R. Part 60, Subpart W or the Landfill NSPS). The Landfill NSPS sets forth operational standards and compliance provisions for gas collection and control systems (GCCS) under 40 C.F.R. § 60.753 and 60.755. In summary, EPA grants your requests.

Livingston Landfill's Request

The Livingston Landfill operates a network of leachate collection piping and leachate cleanout risers. This network of leachate collection piping and leachate cleanout risers is located within the leachate collection media underlying the waste. The leachate cleanout risers are sealed with blind flanges to prevent uncontrolled emissions to the atmosphere, and connected to the GCCS as part of the facility's odor management prevention measures. According to the Livingston Landfill, the leachate cleanout risers' engineered design and sole purpose is to collect and transport collected leachate. The Livingston Landfill asserts that the risers are not necessary in order to meet the 500 ppm surface methane concentration limit.

According to Livingston Landfill, leachate cleanout risers frequently exhibit elevated oxygen concentrations based on their designed intention to convey liquid and the pumping operation sequences based on liquid levels within the leachate cleanout risers, and that elevated oxygen levels are difficult to correct due to the system's design.

The purpose of the Livingston Landfill's letter is to request to operate a leachate cleanout riser, LCR LIV-L352 consistent with an alternative operating procedure first set forth in a November 7, 2008 determination by EPA Region 4. This determination allows, under certain circumstances, that leachate cleanout risers remain shut off, under positive pressure, with monthly monitoring and periodic adjustments to the vacuum to remove accumulated landfill gas. This procedure has been approved by EPA in situations where intermittent connection to the GCCS would result in lower emissions than permanently disconnecting the collector, and these procedures have historically been approved at several leachate cleanout risers at the Livingston Landfill. Recently, monthly methane and oxygen monitoring has suggested declining gas quality and rising oxygen content from LCR LIV-L352.

EPA's Findings

EPA approves the Livingston Landfill's request for alternative operating procedures for leachate cleanout riser LCR LIV-L352 based on the fact there have been no documented surface emission exceedances in the vicinity of wells, it is sealed with blind flanges, and monthly wellhead monitoring has demonstrated declining gas quality.

Specifically, EPA approves the below described alternate procedure for leachate cleanout riser LCR LIV-L352:

1. When the oxygen concentration at the collector does not decline to acceptable levels after more than one hour of reduced vacuum, the location may be shut off until the gas quality recovers.
2. The monthly monitoring required by 40 C.F.R. Part 60, Subpart WWW will be conducted at the collector but positive pressure or elevated oxygen concentrations will not be considered as exceedances of the operating limits in 40 C.F.R. § 60.753. However, the monthly monitoring results must be reported to the Illinois EPA in the Livingston Landfill's semi-annual NSPS report. The reports to Illinois EPA shall note if and when the leachate collector is shut off in accordance with this letter.
3. If monthly monitoring indicates that pressure has built up in the leachate collector and the oxygen concentration still exceeds 5 percent, the collector will be briefly opened to relieve the pressure and may then be shut down until it is monitored the following month.
4. The surface monitoring required by 40 C.F.R. Part 60, Subpart WWW will continue to be conducted in this area. Standard remediation steps, including evaluating the need to return the collector to full-time service, must be followed if exceedances of the 500 ppm methane surface concentration limit are detected in the immediate vicinity.
5. If the monthly monitoring indicates that gas quality has improved (i.e., the oxygen concentration has dropped below 5 percent), the collector will be brought back on line until the gas quality declines again. **If the oxygen levels can be maintained below the regulatory limit of 5 percent, this alternate operating procedure is terminated and the leachate collector shall be operated in accordance with the regulatory requirements.**

Livingston Landfill also requests an amendment to the currently existing alternative operating

procedure EPA approved for other leachate cleanout risers at the landfill. Livingston Landfill requests that the monthly monitoring data for each of these wells be reported semi-annually as part of the NSPS semi-annual report. This request is approved. Rather than submitting individual monthly reports to Illinois EPA, Livingston Landfill may accumulate 6 months of monitoring data, and submit this data to Illinois EPA as part of its semi-annual NSPS report.

If you have any further questions please contact Nathan Frank of my staff at 312-886-3850.

Sincerely,



Sara Breneman
Chief
Air Enforcement and Compliance Assurance Branch

cc: Eric Jones, Manager
Bureau of Air, Compliance Unit
Illinois Environmental Protection Agency

CERTIFICATE OF MAILING

I, Chynna Hampton, certify that I sent a response to the Livingston Landfill's requests for alternative operating procedures for leachate cleanout riser LCR LIV-L352 by Certified Mail, Return Receipt Requested, to

Eric Dippon
Environmental Manager
American Disposal Services of Illinois, Inc.
Livingston Landfill
14206 E 2100 N. Road
Pontiac, Illinois 61764

I also certify that I sent a copy of the response to the Livingston Landfill's requests for alternative operating procedures for leachate cleanout riser LCR LIV-L352 pursuant to the Clean Air Act by First Class Mail to:

Eric Jones, Manager
Bureau of Air, Compliance Unit
Illinois Environmental Protection Agency
P.O. Box 19506
Springfield, Illinois 62794

On the 29 day of December 2015.



Kathy Jones
Program Technician
AECAB, PAS

Certified Mail Receipt Number: 7014 2870 0001 9581 4049

E.4 & E.8 USEPA LETTER TO AKRON REGIONAL LANDFILL

AE-17J

Darrin F. Hartman
Compliance Coordinator/LFG Technician
Akron Regional Landfill, Inc.
P.O. Box 13680
Akron, Ohio 44334

Dear Mr. Hartman:

The United States Environmental Protection Agency (U.S. EPA) has reviewed your December 17, 2002, letter regarding Akron Regional Landfill Inc.'s (ARLI or you) request for variance. The variance request was submitted for your Municipal Solid Waste (MSW) landfill in Akron, Ohio. This MSW landfill is subject to the **Standards of Performance for Municipal Solid Waste Landfills**, 40 C.F.R. Part 60, Subpart WWW.

Specifically, your variance request pertains to gas wells OLD-1, OLD-2, OLD-3, and OLD-4, and you also request allowance for the wells to be shut down. You report that the four wells have oxygen readings that consistently exceed the NSPS threshold of 5% and that measured temperatures usually reflect the ambient temperature of the air. You state that landfills undergoing the mesophilic stage of decomposition should consistently exhibit temperatures in the range of 70°F and 110°F regardless of the ambient air temperature. Given the poor rate of gas generation in the area of the four wells, we do not believe U.S. EPA needs to act on this variance request. ARLI has discretion in operating its gas collection wells in conformance with the operational standards at 40 C.F.R. § 60.753.

If ARLI locks out the vacuum valves for each well, but keeps in place each of the well casings and heads, then we would view this as an operational change rather than a design change, which must conform with the operational standards at 40 C.F.R. § 60.753.

ARLI must continue with surface monitoring as required at 40 C.F.R. § 60.753(d) in the vicinity of such decommissioned wells to assure the gas collection system is operating in conformance with the operational standards, and effectively controlling any landfill gas emissions from this area of the landfill. This may entail re-starting the wells to address any surface monitoring

exceedances in the area influenced by the wells, or in adjacent areas. We also require that ARLI update the facility diagrams to reflect which wells are in operation.

If ARLI physically removes one or more wells, such a removal would constitute a design change, requiring approval of the Administrator or his/her authorized representative, per 40 C.F.R. § 60.753(b)(3). For such a change, U.S. EPA would require a registered professional engineer to certify that removal of the well(s) will not reduce the capability of the gas collection system to meet the operational requirements of 40 C.F.R. § 60.753.

If you have any questions regarding this determination, feel free to contact Julie Monahan, of my staff, at (312) 886-0120.

Sincerely yours,

George T. Czerniak, Chief
Air Enforcement and Compliance Assurance Branch

cc: Lynn Malcolm
Akron Regional Air Quality Management District

cc: Lynn Malcolm
Akron Regional Air Quality Management District
146 South High Street Room 904
Akron, Ohio 44308

standard bcc's: official file copy w/attachment(s)
 branch reading file copy w/attachment(s)
 originator reading file copy w/attachment(s)

other bcc's: J. Gahrts
 L. Roberts

Creation Date:	November 16, 2005
Filename:	C:\EPAWork\Landfills\Landfill AD\akronwelldecom.wpd
Legend:	ARD:AECAB:AECAS (MN/OH) :JMonahan

E.5 USEPA/ADI CONTROL NUMBERS 0800012 AND 0600062



U.S. Environmental Protection Agency Applicability Determination Index

Control Number: 0800012

Category: NSPS
EPA Office: Region 4
Date: 05/31/2007
Title: Applicability of Well Monitoring Requirements
Recipient: Stephens, Barry R.
Author: Banister, Beverly H.
Comments:

Part 60, WWW Municipal Solid Waste Landfills

References:

- 60.753(a)
- 60.753(b)
- 60.753(c)
- 60.755(a)
- 60.753
- 60.755
- 60.753(a)(2)

Abstract:

Q: Does EPA approve delaying implementation of the pressure, temperature, and oxygen monitoring requirements under 40 CFR part 60, subpart WWW until September 2010, for seven wells that are located in an active area that first received waste in September 2005, at the Chestnut Ridge Landfill in Heiskell, Tennessee?

A: EPA finds that the proposal to delay monitoring for these wells would be consistent with the intent of § 60.753 in NSPS subpart WWW provided that the area of the landfill where the wells are located is not closed or does not reach final grade prior to September 2010.

Letter:

Barry R. Stephens, P.E., Director
Division of Air Pollution Control
TN Dept. of Environment & Conservation
9th Floor, L&C Annex
401 Church Street
Nashville, TN 37243-1531

Dear Mr. Stephens:

This letter is in response to a letter in which Lacey J. Hardin of your staff requested a determination regarding an applicability issue that the Waste Management Company (WMC) raised regarding seven gas extraction wells at the Chestnut Ridge Landfill in Heiskell, Tennessee. This landfill is subject to 40 CFR Part 60, Subpart WWW (Standards of Performance for Municipal Solid Waste Landfills), and WMC

requested that the seven wells in question be exempt from monthly pressure, temperature, and oxygen monitoring requirements until September 2010. Based upon our review of Subpart WWW and the information submitted by WMC, we have determined that exempting the wells in question from pressure, temperature, and oxygen content monitoring would be consistent with the intent of Subpart WWW if this area of the landfill remains active until September 2010 or later. Details regarding the basis for this determination are provided in the remainder of this letter.

Under provisions in 40 CFR Sec. 60.753(a), owners and operators of landfills subject to Subpart WWW are required to operate a gas collection and control system (GCCS) where waste has been in place for five years or more in active areas or where waste has been in place for two years or more in closed areas or in areas that have reached final grade. A number of operating limits for well heads in the GCCS are specified in 40 CFR Sec. 60.753(b) and 40 CFR Sec. 60.753(c). These provisions require that well heads be operated under negative pressure, that well head temperatures be kept below 55 C, and that landfill gas nitrogen or oxygen levels be maintained within specified limits (less than 20 percent for nitrogen or less than 5 percent for oxygen). Under provisions in 40 CFR Sec. 60.755(a), owners and operators of GCCS subject to these operational limits are required to monitor well head pressure, temperature, and gas composition on a monthly basis. When deviations from any of the operating limits in the rule are noted, owners and operators must take corrective action to bring the collection system back into compliance.

According to the letter in which WMC requested a monitoring waiver, the seven wells in question are located in an active area of the Chestnut Ridge Landfill where waste was first placed in September 2005. Based upon the date when this area was first used for waste disposal, the company would not be required to operate gas extraction wells until September 2010. Since the wells in this area were installed prior to the applicable operating deadline in Subpart WWW, WMC asked that they be exempt from temperature, pressure, and oxygen monitoring until September 2010 if the area remains active or until two years after final grade is reached in the area where the wells are located.

Based upon our review of Subpart WWW, the operational requirements in 40 CFR Sec. 60.753 and the associated monitoring requirements in 40 CFR Sec. 60.755 are applicable in areas where a GCCS must be installed and operated under provisions in 40 CFR Sec. 60.753(a). Since the seven wells covered by WMC's request for a monitoring exemption are located in an active area that first received waste in September 2005, they are in an area where a GCCS would not be required under the provisions in 40 CFR Sec. 60.753(a). Because WMC is not currently required to operate a GCCS in this area of the landfill, the pressure, temperature, and oxygen limits in 40 CFR Sec. 60.753 would not apply to the seven well heads covered by the company's request for a monitoring waiver. Therefore WMC's proposal to delay pressure, temperature, and oxygen monitoring for these seven wells until September 2010 would be consistent with the intent of Subpart WWW if this area of the landfill remains active until September 2010 or later.

If any portion of the landfill covered by WMC's waiver request reaches final grade between September 2007 (i.e., two years after the area was first used for waste disposal) and September 2010, the requirement to operate a GCCS would apply at the time final grade is reached. This determination is based upon the provisions in 40 CFR Sec. 60.753(a)(2) that require operation of a GCCS where waste has been in place for two years or more in closed areas or areas at final grade. Therefore, WMC's request that the monitoring waiver for the seven wells in question be extended for two years if final grade is reached prior to September 2010 would not be consistent with the intent of Subpart WWW. If this area of the landfill reaches final grade prior to September 2007, the requirement to have a GCCS and implement the associated monitoring provisions would apply beginning in September 2007. If this area of the landfill reaches final grade after September 2007, but prior to September 2010, the requirement to have a GCCS and implement the associated monitoring would apply at the time final grade is reached.

If you have any questions about the issues addressed in this letter, please contact Mr. David McNeal of the U.S. Environmental Protection Agency Region 4 staff at (404) 562-9102.

Sincerely,

Beverly H. Banister
Director
Air, Pesticides and Toxics
Management Division

EPA Applicability Determinations Index

cc: Lacey J. Hardin
Division of Air Pollution Control
TN Dept. of Environment & Conservation
9th Floor, L&C Annex
401 Church Street
Nashville, TN 37243-1531



U.S. Environmental Protection Agency Applicability Determination Index

Control Number: 0600062

Category: NSPS
EPA Office: Region 4
Date: 02/09/2005
Title: Changes to Standard Operating Procedures
Recipient: Kozlov, L. T.
Author: Banister, Beverly H.
Comments:

Part 60, WWW Municipal Solid Waste Landfills

References: 60.753(b)
 60.753(c)
 60.753(d)
 60.755

Abstract:

Q: May the Orange County Solid Waste Management facility change its standard operating procedures for landfill gas extraction wells, under 40 CFR part 60, subpart WWW, and shut down, as an alternative to decommissioning, the wells where gas flows are so low that applying even minimal vacuum results in air infiltration that causes exceedances of the applicable oxygen concentration limit?

A: Yes. EPA approves the alternative operating procedure provided that that the facility diagrams are updated to indicate which wells have been shutdown because landfill gas production rates are too low to permit continuous extraction. EPA finds that shutting down nonproductive wells, rather than decommissioning them, has the potential to lower overall non-methane organic compounds emissions by making it easier to resume gas collection in nonproductive areas of the landfill that subsequently experience an improvement in gas quality.

Letter:

UNITED STATES ENVIRONMENTAL PROTECTION AGENCY
REGION 4
ATLANTA FEDERAL CENTER
61 FORSYTH STREET
ATLANTA GEORGIA 30303-8960

FEB 09 2005

4APT-ATMB

L.T. Kozlov, P.E.
Program Administrator
Air Resources Management
Central District

Florida Department of Environmental Protection
3319 Maguire Boulevard, Suite 232
Orlando, Florida 32803-3767

Dear Mr. Kozlov:

The purpose of this letter is to provide you with a written determination regarding proposed changes to the standard operating procedures for landfill gas extraction wells at the Orange County Solid Waste Management Facility. This landfill is subject to 40 CFR Part 60, Subpart WWW (Standards of Performance for Municipal Solid Waste Landfills), and in a request sent to the U.S. Environmental Protection Agency (EPA) Region 4 and to your agency, Orange County proposed changes in standard operating procedures for certain wells in the landfill's active gas collection system. These changes involve an alternative to decommissioning wells where low landfill gas generation rates make it difficult to simultaneously operate wellheads at negative pressure and maintain compliance with oxygen concentration limits. Based upon our review, the changes proposed by Orange County are acceptable. Details regarding the County's proposal and the basis for our conclusions are provided in the remainder of this letter.

Operating requirements for gas collection and control systems (GCCS) are promulgated at 40 CFR Sec. 60.753(b), (c), and (d). Under these provisions, wellheads must be operated under negative pressure, the temperature of interior wellheads must be less than 55 degrees C, gas quality limits for interior wells (either less than 20 percent nitrogen or less than five percent oxygen) must be met, and the methane concentration at the surface of the landfill must be less than 500 parts per million (ppm). Under provisions in 40 CFR Sec. 60.755, monitoring to verify compliance with the wellhead pressure, temperature, and gas quality limits must be conducted on a monthly basis. Monitoring to verify compliance with the 500 ppm surface methane concentration limit must be conducted on a quarterly basis.

Orange County's request for approval of changes to its standard operating procedures involves wells where gas flow rates are so low that applying even minimal vacuum results in air infiltration that causes exceedances of the applicable oxygen concentration limit. Shutting such wells down will prevent the air infiltration that leads to the oxygen exceedances, but shutting a well down is likely to cause positive pressure in the wellhead as landfill gas builds up. Therefore, simultaneously complying with both the negative pressure and oxygen concentration limits in 40 CFR Sec. 60.753 can be difficult for wells where gas flow rates have declined over time.

Under provisions in 40 CFR Sec. 60.753(b)(3), wells that experience positive pressure after being shutdown to accommodate declining landfill gas flow rates can be decommissioned if permission is granted by the Administrator. As an alternative to decommissioning wells under the provisions, Orange County has proposed to make the following changes to its standard operating procedure for wells where persistent oxygen exceedances are not the result of operations and/or maintenance issues:

1. Wells where oxygen concentrations do not decline to acceptable levels after more than one hour of reduced vacuum will be shut off until the gas quality recovers.
2. The monthly monitoring required by 40 CFR Sec. 60.755 will be conducted for wells that have been shutdown, but positive pressure or elevated oxygen concentrations will not be considered exceedances of the operating limits in 40 CFR Sec. 60.753.
3. If monthly monitoring indicates that pressure has built up in the well and the oxygen concentration still exceeds five percent, the well will be opened to relieve the pressure and will be shutdown until it is monitored the following month.
4. If the monthly monitoring indicates that gas quality has improved (i.e., the oxygen concentration has dropped below five percent), the well will be brought back on line until the gas quality declines again.
5. The quarterly methane surface concentration monitoring required under 40 CFR Sec. 60.755 will be conducted for wells that have been shutdown. Standard remediation steps, including evaluating the need to return wells to full-time service, will be followed if exceedances of the 500 ppm methane surface concentration limit are detected.

According to Mr. Daniel Morical of Orange County Utilities, the operating procedure changes outlined

above would apply to approximately four or five of the 130 wells at its landfill at any one time. Mr. Morical also indicated that there is a high probability of gas quality improving to the point it would be necessary to restart wells that had been shutdown. Based upon our review, the proposed changes to Orange County's standard operating procedures are acceptable because shutting down nonproductive wells, instead of decommissioning them, has the potential to lower overall nonmethane organic compound (NMOC) emissions at the landfill. This potential increase in NMOC control system efficiency stems from the ability to quickly resume gas collection if there are improvements in the gas quality or increases in the gas production rate in an area of the landfill where wells have become nonproductive. If wells in a nonproductive area are decommissioned, instead of merely being shutdown, NMOC emissions would not be controlled between the time an exceedance is identified and a new well is installed. Once condition for approval of the proposed changes in standard operating procedures at the Orange County Solid Waste Management Facility is that facility diagrams must be updated to indicate which wells have been shutdown because landfill gas production rates are too low to permit continuous extraction.

If you have any questions about the determination provided in this letter, please contact Mr. David McNeal of the EPA Region 4 staff at (404) 562-9102.

Sincerely,

Beverly H. Banister
Director
Air, Pesticides & Toxics
Management Division

cc: Daniel Morical
Orange County Utilities - Solid Waste Division
5901 Young Pine Road
Orlando, Florida 32829

E.10 USEPA/ADI CONTROL NUMBER 0900059

Regulatory Background

Under the provisions of 40 CFR § 60.753(a), owners or operators of landfills subject to Subpart WWW are required to operate a gas collection and control system ("GCCS") where waste has been in place for five years or more in active areas or where waste has been in place for two years or more in closed areas that have reached final grade. A number of operating limits for wellheads in the GCCS are specified in 40 CFR § 60.753(b) and 60.753(c). These provisions require that wellheads be operated under negative pressure, with a landfill gas temperature less than 55 degrees Celcius and with either a nitrogen level less than 20 percent or an oxygen level less than 5 percent.

Per 40 CFR § 60.755(a), owners or operators of GCCS subject to these operational limits are required to monitor wellhead pressure, temperature and gas composition on a monthly basis. When exceedances of any of the operating limits in the rule are noted, owners or operators must take corrective action to bring the collection system back into compliance. If the exceedances cannot be remedied within 15 days, the GCCS system must be expanded to correct the deviations within 120 days of the initial exceedance. However, an alternative timeline for compliance can be requested from the Administrator for approval.

In addition, 40 CFR § 60.753(d) allows areas of steep slopes or other dangerous areas to be excluded from surface testing.

Roxana's Requests

The June 30, August 23 and September 23, 2008 letters together make five requests to EPA:

Request 1: Request for Approval of Alternative Monitoring Procedure or Alternative Compliance Timeline for Wells 9, 36, 41, 44, and 47

Roxana was unable to perform the required monthly monitoring for landfill gas extraction wells 9, 36, 41, 44, and 47 in May 2008 due to landfill conditions in the areas of these wells. The above referenced wells are located in the active face of the landfill. According to Roxana, these conditions made it unsafe for operations and maintenance personnel to conduct the required monthly monitoring. Roxana explains that wells which are placed in active areas periodically need to be raised (i.e., the well casing extended 15 to 25 feet vertically) in order to not be buried under lifts of trash. When they are raised, the HDPE line which provides the applied vacuum is temporarily disconnected until the surrounding lift of trash is brought high enough to reconnect the well. The time frame between when a well is disconnected and raised, and when the waste height is high enough to reconnect the lateral, can often range from a few weeks to a few months. This can result in missed monthly readings at the well, since the well casing is too high for the technician to safely reach. Roxana originally requested until September 30, 2008 to allow for filling activities to cease in this area and allow safe access to the identified landfill gas monitoring wells. However, the September 23, 2008 letter states that the wells were able to be monitored in June 2008 and therefore only one month of monitoring was missed. Roxana has reported the failure to monitor to the Illinois EPA via a submittal dated May 30, 2008 of the required Excess Emissions, Monitoring, Equipment Downtime, and Miscellaneous Reporting Form under the Title 5 permitting program.

EPA's Determination on Request 1

Based upon our review of the information submitted by Roxana, we agree that the request to exempt wells 9, 36, 41, 44, and 47 from one month of monitoring is acceptable based upon the following factors:

1. Roxana's concerns about safety and the ability to make adjustments for wells that have been raised to between 15 to 25 feet in the air appears legitimate.
2. The number of wells that will be covered by this monitoring exemption is about 6.25 percent of the wells located at the site. Currently, there are more than 80 gas extraction wells at the landfill, and Roxana's request covers 5 wells.
3. Per 40 CFR § 60.752(b)(2)(v), the GCCS for a closed landfill cannot be removed until it has been in operation for at least 15 years. Since this provision also prohibits the GCCS from being removed until NMOC emissions are less than 50 MG per year, the actual operating life of the GCCS at the Roxana landfill could be considerably longer than 15 years. In the context of the operating life of the GCCS, the

duration of the proposed monitoring exemption (one month) is relatively short.

Request 2: Request for Alternative Timeline to Fix Well 46

According to the June 30, 2008 letter, gas extraction well 46 was hit and became inoperable as a result of construction in the area. The well was capped and is being replaced as part of the installation of new landfill gas extraction wells. As of September 23, 2008, the well remained inoperable. Roxana requests until approximately December 23, 2008 to complete the installation of this well and bring the well online. Roxana also reported this event via the Excess Emissions, Monitoring Equipment Downtime, and Miscellaneous Report Form under Title 5.

EPA's Determination on Request 2

EPA will grant Roxana an alternative compliance timeline of not more than 120 days from the date well 46 became inoperable to fix the well and bring it back into compliance. Since the well became inoperable in June, Roxana has until sometime in October to fix this well (120 day from the date in June when the well became inoperable). EPA will not grant Roxana until December to fix this well.

Request 3: Request for Alternative Compliance Timeline for Wells 25 and 36 for Oxygen Exceedances

The August 23 and September 23, 2008 letters request additional time to bring wells 25 and 36 back into compliance for oxygen exceedances which occurred in August 2008. Roxana suspects that well 25 is blocked and will require re-drilling. Well 36 experienced high liquid levels but was brought back into compliance in September 2008. Roxana first requested 90 days from August 23 to repair well 25 but now requests 90 days from September 23 to repair well 25.

EPA's Determination on Request 3

Since well 36 returned to compliance in September 2008, EPA will approve an alternative compliance timeline from the date of the monthly monitoring in August 2008 to the date of the monthly monitoring in September 2008 when the well returned to compliance. For well 25, EPA will only approve an alternative timeline of 90 days from August 23, 2008 to return this well to compliance.

Request 4: Request for Alternative Timeline for Wells 38, 39, 40, 41, 44, 45, 47, and 75 for Pressure Exceedances

The August 23 and September 23, 2008 letters request additional time to bring the following wells back into compliance: 38, 39, 40, 41, 44, 45, 47 and 75. The wells exhibited positive pressure during the August 2008 monthly monitoring event. The above reference wells are located in the area of the landfill undergoing construction activities for the installation of additional wells. Roxana originally requested three months to complete construction activities, including the installation, replacement and re-drilling of wells to bring all wells back into compliance. In the September 23, 2008 letter, however, Roxana explained that wells 38, 39, 40, 41, 44, 45 and 47 all returned to compliance in September 2008. Well 75 still has a positive pressure and Roxana requests 90 days from September 23, 2008 to bring well 75 back into compliance.

EPA's Determination on Request 4

Since wells 38, 39, 40, 41, 44, 45 and 47 returned to compliance in September 2008, EPA will approve an alternative compliance timeline from the monthly monitoring date in August 2008 to the monthly monitoring date in September 2008 (approximately 30 days). For well 75, EPA will approve an alternative timeline of 120 days from the date of the initial exceedance in August 2008 to return this well to compliance.

Request 5: Request for Alternative Compliance Timeline for Wells 30, 31, 32, and 33

Wells 30, 31, 32 and 33 showed positive pressure during the monthly monitoring event on September 23, 2008. No vacuum is currently available for these wells because they are disconnected due to the construction activities. Roxana requests 90 days from September 23, 2008 to re-connect these wells and bring them back into compliance.

EPA's Determination on Request 5

EPA Applicability Determinations Index

EPA will approve an alternative compliance date of 90 days from September 23, 2008, which is the date of the initial pressure exceedance, to bring these wells back into compliance.

If you have any questions about the determination provided in this letter, please contact Ms. Linda H. Rosen, of my staff, at (312) 886-6810.

Sincerely,

George T. Czerniak
Chief
Air Compliance and Compliance Assurance Branch

cc: Ray Pilapil, Manager
Bureau of Air - Compliance and Enforcement Section
Illinois Environmental Protection Agency

Yasmine Keppner
Bureau of Air - Compliance and Enforcement Section Illinois Environmental Protection Agency

1 Although the September 23, 2008 letter did not list well 44 as returning to compliance, Ms. Rachelle Maxheimer informed Ms. Linda Rosen, EPA, during an October 1, 2008 phone call that well 44 did indeed return to compliance in September 2008.

E.11 USEPA/ADI CONTROL NUMBERS 0800010



U.S. Environmental Protection Agency Applicability Determination Index

Control Number: 0800010

Category: NSPS
EPA Office: Region 4
Date: 03/15/2007
Title: Operational and Monitoring Alternatives
Recipient: Reece, Myra
Author: Banister, Beverly H.
Comments: See related ADI determination, Control No. 0400033.

Part 60, WWW Municipal Solid Waste Landfills

References:

- 60.753(a)(1)
- 60.753
- 60.755(c), 60.753(d)
- 60.753(c)(3)
- 60.756(b)(1)

Abstract:

Q1: Is a proposal to delay the installation of gas collection wells in active areas that have held waste for five years or more at the Three Rivers Landfill in Aiken County, South Carolina acceptable under 40 CFR part 60, subpart WWW?

A1: No. EPA finds that the proposal is not acceptable under NSPS subpart WWW since the collection system would be less effective than that required under provisions in 40 CFR Â§ 60.753. The use of the leachate collection system only to extract gas from active areas that have held waste for five years or more will result in a less effective system than one that incorporates both the leachate system components and properly located extraction wells.

Q2: Does EPA allow quarterly methane surface concentration monitoring to be waived for roads, active areas, truck traffic areas, and areas with slopes greater than 3:1, at the Three Rivers Landfill located in Aiken County, South Carolina, under 40 CFR part 60, subpart WWW?

A2: EPA waives the monitoring for roads, but not for the other areas covered by the request under NSPS subpart WWW. Based upon previous EPA determinations, surface methane monitoring requirements cannot be waived for active areas, truck traffic areas, or areas with slopes less than 4:1.

Q3: Does EPA find that a probe may be placed near the tops of vegetation as an alternative to placing the methane surface concentration monitoring probe within five to ten centimeters of the landfill surface, at the Three Rivers Landfill in Aiken County, South Carolina under 40 CFR part 60, subpart WWW?

A3: No. EPA finds this proposal is not acceptable under NSPS subpart WWW because dilution of the sample will result in the methane concentration being lower at the top of vegetation than it is at the landfill surface.

Q4: Does EPA waive the requirement to monitor the temperature of internal combustion engines used as control devices at the Three Rivers Landfill be waived under 40 CFR part 60, subpart WWW?

A4: No. Although EPA finds that the combustion temperature monitoring requirement cannot be waived under NSPS subpart WWW, EPA has approved temperature monitoring alternatives in the past. Therefore, Three Rivers Landfill may want to consider approval of a similar alternative for its site.

Q5: Does EPA approve the use of an orifice plate for measuring the flow rate to the flare that serves as backup control device at the Three Rivers Landfill under 40 CFR part 60, subpart WWW?

A5: Yes. The use of orifice plates are commonly used for measuring process flow rates, therefore, such practice is appropriate and does not require prior EPA approval for use at the Three Rivers Landfill.

Q6: Does EPA approve the use of a continuous relighter as an alternative to a heat sensing device, such as an ultraviolet beam sensor or thermocouple at the pilot light or in the flame, for a back up flare expected to operate for 120 days or less per year at the Three Rivers Landfill under 40 CFR part 60, subpart WWW?

A6: No. EPA determines that a continuous relighter is not an acceptable substitute for a heat sensing device under NSPS subpart WWW, as stated in a previous EPA determination.

Letter:

4APT-ATMB

Myra Reece, Chief
Bureau of Air Quality Control
South Carolina Department of
Health and Environmental Control
2600 Bull Street
Columbia, SC 29201

Dear Ms. Reece:

The purpose of this letter is to provide you with a written determination regarding several operational and monitoring alternatives proposed for the Three Rivers Landfill located in Aiken County, South Carolina. This landfill is subject to 40 CFR part 60, Subpart WWW (Standards of Performance for Municipal Solid Waste Landfills), and the alternatives for this site were described in the landfill's collection and control system design plan. Denise Hall of your Agency forwarded a copy of this design plan to the U.S. Environmental Protection Agency (EPA) Region 4 because the authority to approve several of the alternatives proposed in it has been delegated to the Region. The remainder of this letter describes the alternatives proposed for the Three Rivers Landfill and provides our determination regarding each proposal.

The first alternative proposed in the design plan involves the requirement to install gas collection wells in all active areas that have held waste for five years or more. This requirement is promulgated at 40 CFR Sec. 60.753(a)(1), and the design plan proposes to delay the installation of wells until active areas have reached final grade even if waste has been in place in the active area for five years or more. Under this proposal, leachate collection risers would be used for gas extraction until final grade is reached. Based upon our review, this proposal is not acceptable because using only the leachate collection system to extract gas from active areas that have held waste for five years or more will result in a less effective system than one that incorporates both the leachate system components and properly located extraction wells. Since Subpart WWW does not provide the authority to approve a collection system that is less effective than that specified under the provisions in 40 CFR Sec. 60.753, the proposal to delay the installation of gas extraction wells in active areas that have held waste for five years or more is not acceptable.

The second alternative proposed in the design plan involves the exclusion of dangerous areas from the quarterly methane surface concentration monitoring required under 40 CFR Sec. 60.755(c). According to 40 CFR Sec. 60.753(d), areas with steep slopes or other dangerous areas may be excluded during this monitoring, and the design plan proposes to exclude roads, active areas, truck traffic areas, and slopes greater than 3:1 from surface monitoring under these provisions. Of the four potentially excluded areas identified in the design plan, roads are the only one where the quarterly monitoring requirement can be waived. Under Subpart WWW, surface methane concentration levels must be checked at 30

meter intervals, and based upon the dimension of typical roads, it should be possible to exclude them from the quarterly monitoring without making major deviations from the 30-meter spacing requirement. EPA has previously denied requests to waive monitoring requirements in active areas where a gas collection system is required (i.e., active areas that have held waste five years or more) or in steep areas with a slope of less than 4:1 (see enclosed EPA Region 4 determination dated April 28, 2000). Based on EPA's previous determinations, quarterly methane surface concentration monitoring cannot be waived in active areas, truck traffic areas, or areas with slopes less than 4:1.

The third alternative proposed in the design plan involves the placement of the probe inlet during the quarterly surface methane concentration monitoring. According to 40 CFR Sec. 60.755(c)(3), the probe inlet must be placed within five to ten centimeters of the ground during the monitoring. As an alternative to these provisions, the design plan proposes to conduct monitoring near the top of vegetation in areas where meeting the five to ten centimeter requirements may cause the probe to become clogged with debris, dirt, or grass. EPA has previously denied requests of this type because the methane concentration at the top of vegetation will be lower than it would be nearer the landfill surface as a result of dilution (see enclosed EPA Region 7 determination dated February 19, 2004). Based upon EPA's previous determinations, the alternative monitoring procedures proposed for areas with vegetation are not acceptable.

The fourth alternative proposed in the design plan involves the temperature monitoring requirement for combustion devices. Under 40 CFR Sec. 60.756(b)(1), owners/operators are required to monitor the temperature of enclosed combustion devices. The primary control devices at the Three Rivers Landfill are internal combustion engines, and the design plan asks that the temperature monitoring and recordkeeping requirement be waived for these engines. The factors cited to support this request are the difficulties associated with measuring combustion temperatures in an engine and questions about whether internal combustion engines should be classified as enclosed combustors.

Based upon previous EPA determinations (provided as enclosures with this letter), the requirement to monitor the temperature of internal combustion engines at landfills cannot be waived, but alternative monitoring approaches or locations may be acceptable. One of these determinations is dated April 7, 2003, and it indicates that the requirement to monitor the combustion temperature of engines used to control landfill emissions cannot be waived because such engines are considered enclosed combustors. This determination did, however, provide the landfill owner/operator with the opportunity to pursue an alternative monitoring approach based upon the oxygen concentration level in the engine's exhaust gas. In another determination dated February 27, 2004, EPA Region 3 approved post-combustion temperature monitoring for a landfill gas fired turbine, and the basis for this approval was the difficulty associated with measuring the temperature in the turbine's combustion zone. Consistent with EPA's previous determinations, we cannot waive the temperature monitoring requirement for the internal combustion engines at the Three Rivers Landfill, but the site's owner/operator may want to consider requesting approval for an alternative monitoring approach or location.

The fifth alternative proposed in the design plan involves the requirement to monitor the flow rate to the flare used as a backup control device at the Three Rivers Landfill. According to the design plan, a log indicating the startup and shutdown times for the flare will be maintained and an orifice plate will be used to determine the quantity of gas burned when the flare is in use. The plan refers to this as a flow monitoring alternative, but EPA approval to measure the flow rates with an orifice plate does not appear necessary since orifice plates are commonly used to measure process flow rates in a wide range of applications.

The sixth alternative proposed in the design plan involves the requirement to install and operate a heat sensing device, such as an ultraviolet beam sensor or thermocouple at the pilot light or in the flame of the flare used as a backup control device at the Three Rivers Landfill. As an alternative to this requirement, the design plan proposes the installation of a continuous relighter if the flare is expected to run for more than 120 days per year. Based upon the wording of this proposal, the plan also appears to be requesting a waiver of the temperature monitoring requirement if the flare is expected to operate for 120 days or less per year. After considering these proposals, we have determined that the requirement to monitor for the presence of a flame in the flare cannot be waived, irrespective of the number of days the flare operates. In addition, EPA has previously determined that a constant sparking device is not an acceptable alternative to a heat sensing device (see enclosed Region 3 letter dated July 12, 2001). Based upon this previous determination, the proposal to substitute a continuous relighter for a heat sensing device on the flare at the Three Rivers Landfill is not acceptable.



LEGEND

---	PROPERTY BOUNDARY
---	EXISTING SOLID WASTE BOUNDARY
---	EXISTING PHASE BOUNDARY
---	EXISTING 10' CONTOUR
---	EXISTING LANDFILL GAS HEADER
---	EXISTING HORIZONTAL COLLECTOR
+	EXISTING LFG EXTRACTION WELL
+	EXISTING REMOTE WELLHEAD
+	EXISTING HEADER ACCESS RISER
+	EXISTING ISOLATION VALVE
+	EXISTING BLIND FLANGE
+	EXISTING FLANGE CONNECTION
+	EXISTING REDUCER FITTING
+	EXISTING CONDENSATE DRIPLEG
+	EXISTING LEACHATE CLEANOUT RISER
+	EXISTING MANHOLE
+	EXISTING ROAD CROSSING
+	EXISTING FINAL COVER AREA
→	PROPOSED SURFACE EMISSIONS MONITORING PATHWAY

- NOTES:**
- GRADES SHOWN REFLECT ANTICIPATED FINAL DEVELOPMENT ELEVATIONS.
 - SURFACE EMISSIONS MONITORING PATHWAY REPRESENTS FINAL GRADE CONDITIONS. INTERIM PATHWAYS WILL BE MONITORED BASED UPON THE SEQUENCE AND EXTENT OF WASTE PLACEMENT AND GCSS DEVELOPMENT, IN ACCORDANCE WITH NSPS.
 - TYPICAL SPACING FOR SERPENTINE PATTERN IS APPROXIMATELY 30 METERS (100 FT). SOME LOCAL VARIATIONS MAY OCCUR TO ACCOMMODATE LANDFILL PHASING AND FIELD CONDITIONS AT THE TIME OF MONITORING.
 - AN ALTERNATE SEM PATTERN OF 60 METERS MAY BE USED IN AREAS EMPLOYING AN FML FINAL COVER SYSTEM.
 - MONITORING TO BE PERFORMED IN ACCORDANCE WITH 40 CFR 62, SUBPART 600, 62.16718(a)(6), AND 40 CFR 63, NESHAP SUBPART AAAA, 63.1960(a)(c).
 - THE FACILITY MAY EXCLUDE DANGEROUS AREAS, SUCH AS ROAD, THE ACTIVE FILL AREA, TRUCK TRAFFIC AREAS, AREAS WITH SNOW OR ICE COVER AND SLOPES STEEPER THAN OR EQUAL TO 3:1 FROM SURFACE TESTING.

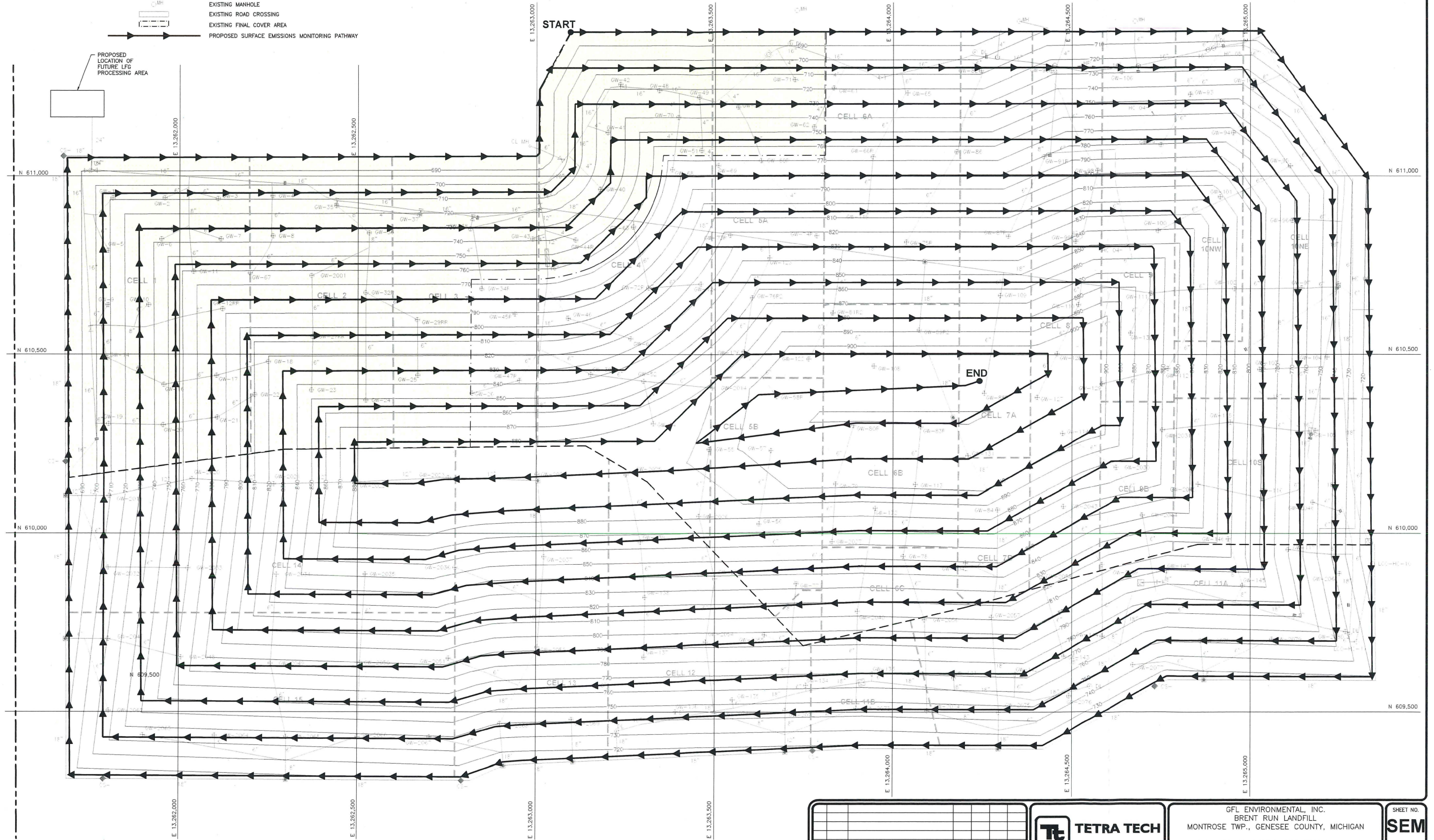
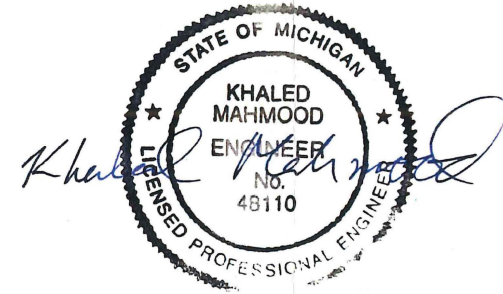

1" = 100' 0"

DATE: 5/1/23

PROJECT: BRENT RUN LANDFILL

SHEET: SEM-01

REV	DATE	DESCRIPTION	DWN BY	DES BY	CHK BY	APP BY
1	5/1/23					



GFL ENVIRONMENTAL, INC.
BRENT RUN LANDFILL
MONTROSE TWP., GENESEE COUNTY, MICHIGAN

**LANDFILL GAS COLLECTION AND CONTROL SYSTEM
SURFACE EMISSIONS MONITORING PLAN**

SHEET NO.
SEM

PROJECT NO.
209-4231207

This document represents intellectual property of Tetra Tech. Any modification to the original or other Tetra Tech documents without the original author and as such is prohibited. Tetra Tech will not be held liable for any errors or omissions in this document without notice, and shall not be held liable for any damages resulting from the use of this document.

NSPS DESIGN PLANS FOR THE LANDFILL GAS COLLECTION AND CONTROL SYSTEM BRENT RUN LANDFILL MONTROSE TWP., GENESEE COUNTY, MICHIGAN

MAY 2023



PREPARED FOR:

**BRENT RUN, INC.
8335 W. VIENNA ROAD
MONTROSE TWP., GENESEE COUNTY, MI 48457**

SHEET INDEX	
1	EXISTING CONDITIONS SITE PLAN
2	FINAL DEVELOPMENT SITE PLAN
DS1	DETAILS
DS2	DETAILS

PREPARED BY:



TETRA TECH

39395 WEST TWELVE MILE ROAD
SUITE 103
FARMINGTON HILLS, MICHIGAN 48331
Tel: (877) 633-5520
Fax (248) 994-5456

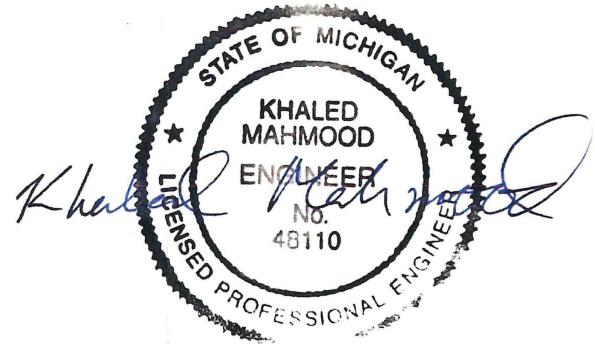

1" 1/2" 0" 1"

This drawing represents intellectual property of Tetra Tech. Any modification to the original by other than Tetra Tech personnel violates its original purpose and as such is rendered void. Tetra Tech will not be held liable for any changes made to this document without express written consent of the originator.

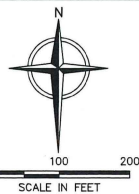

LEGEND

	PROPERTY BOUNDARY
	EXISTING SOLID WASTE BOUNDARY
	EXISTING PHASE BOUNDARY
	EXISTING 10' CONTOUR
	EXISTING 2' CONTOUR
	EXISTING LANDFILL GAS HEADER
	EXISTING HORIZONTAL COLLECTOR
	EXISTING LFG EXTRACTION WELL
	EXISTING REMOTE WELLHEAD
	EXISTING HEADER ACCESS RISER
	EXISTING ISOLATION VALVE
	EXISTING BLIND FLANGE
	EXISTING FLANGE CONNECTION
	EXISTING REDUCER FITTING
	EXISTING CONDENSATE DRIPLEG
	EXISTING LEACHATE CLEANOUT RISER
	EXISTING MANHOLE
	EXISTING ROAD CROSSING
	EXISTING FINAL COVER AREA

- NOTES:**
1. TOPOGRAPHIC SURVEY MAP AERIAL SURVEY PERFORMED BY SNIFFER ROBOTICS, LLC. ON OCTOBER 11, 2022.
 2. AS-BUILT GAS COLLECTION AND CONTROL SYSTEM DESIGN PROVIDED BY TETRA TECH IN DRAWING TITLED "GCCS 2021 RECORD PLAN" DATED 12/19/22.

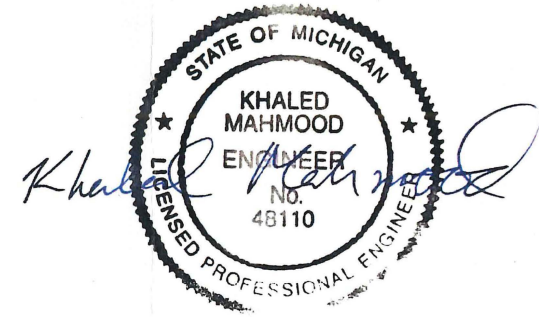

1" = 1/2" 0'
 File: P:\PROJECTS\BRENT RUN\BRENT RUN\GCCS 2021\GCCS 2021\GCCS 2021.dwg
 Plot: P:\PROJECTS\BRENT RUN\BRENT RUN\GCCS 2021\GCCS 2021\GCCS 2021.plt
 Date: 5/1/23
 Time: 10:00:00 AM
 User: KMAHMOED

REV	DATE	DESCRIPTION	DWN BY	DES BY	CHK BY	APP BY
1	5/1/23					



GFL ENVIRONMENTAL, INC.
 BRENT RUN LANDFILL
 MONTROSE TWP., GENESEE COUNTY, MICHIGAN
LANDFILL GAS COLLECTION AND CONTROL SYSTEM
EXISTING CONDITIONS SITE PLAN

SHEET NO.
1
 PROJECT NO.
 209-4231207

This drawing represents intellectual property of Tetra Tech. Any modification to the original design shall be made by Tetra Tech. No other person shall be permitted to reproduce or use this drawing without the written consent of Tetra Tech.

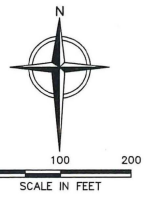

- LEGEND**
- PROPERTY BOUNDARY
 - EXISTING SOLID WASTE BOUNDARY
 - EXISTING PHASE BOUNDARY
 - PROPOSED 10' CONTOUR
 - EXISTING LANDFILL GAS HEADER
 - EXISTING HORIZONTAL COLLECTOR
 - ⊕ GW- EXISTING LFG EXTRACTION WELL
 - ⊕ EXISTING REMOTE WELLHEAD
 - ⊕ EXISTING HEADER ACCESS RISER
 - ⊕ EXISTING ISOLATION VALVE
 - ⊕ EXISTING BLIND FLANGE
 - ⊕ EXISTING FLANGE CONNECTION
 - ⊕ EXISTING REDUCER FITTING
 - ⊕ EXISTING CONDENSATE DRIPLEG
 - ⊕ EXISTING LEACHATE CLEANOUT RISER
 - ⊕ EXISTING MANHOLE
 - ⊕ EXISTING ROAD CROSSING
 - ⊕ EXISTING FINAL COVER AREA

- 6" PROPOSED LANDFILL GAS HEADER/LATERAL
- ⊕ GW- PROPOSED LFG EXTRACTION WELL
- ⊕ PROPOSED FLANGE CONNECTION
- ⊕ PROPOSED HEADER ACCESS RISER
- ⊕ CS- PROPOSED CONDENSATE SUMP
- ⊕ PROPOSED HEADER ISOLATION VALVE

- NOTES:**
- GRADES SHOWN REFLECT ANTICIPATED FINAL DEVELOPMENT ELEVATIONS.
 - EXISTING GAS COLLECTION AND CONTROL SYSTEM COMPONENTS PROVIDED BY TETRA TECH IN DRAWING TITLED "GCCS 2021 RECORD PLAN" DATED 12/19/22.

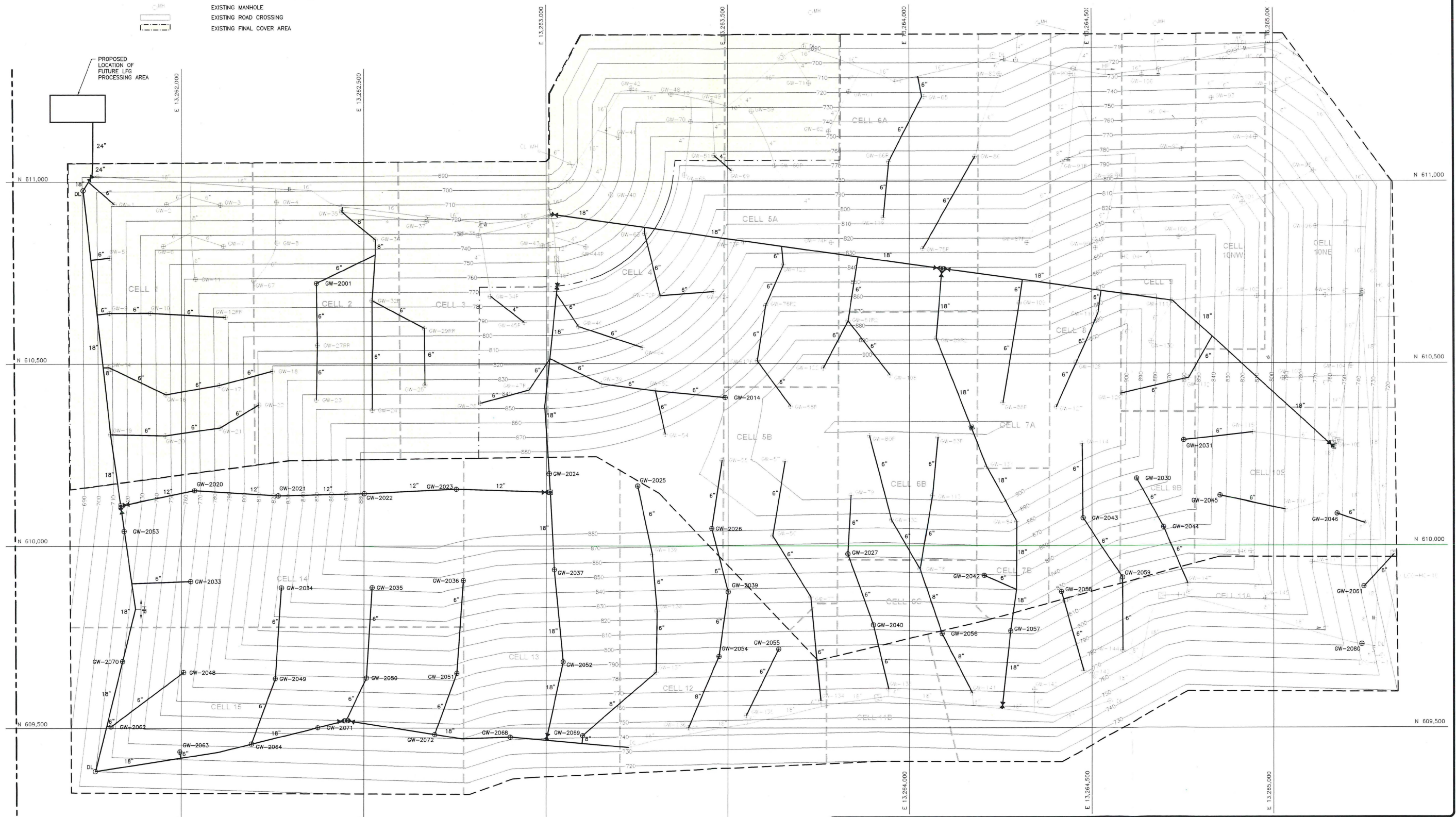

File: P:\PROJECTS\BRENT RUN\GCCS 2021\DWG\GCCS 2021 Final Development Plan.dwg
 User: KMAHMOOD
 Date: 5/1/23
 Scale: 1" = 100'

REV	DATE	DESCRIPTION	DWN BY	DES BY	CHK BY	APP BY
1	5/1/23	ISSUE FOR PERMIT	NUL	NUL	JPS	KM



GFL ENVIRONMENTAL, INC.
 BRENT RUN LANDFILL
 MONTROSE TWP., GENESEE COUNTY, MICHIGAN
**LANDFILL GAS COLLECTION AND CONTROL SYSTEM
 FINAL DEVELOPMENT PLAN**

SHEET NO.
2
 PROJECT NO.
 209-4231207

This drawing represents intellectual property of Tetra Tech. Any modification to the original design shall be made by Tetra Tech personnel under the direct supervision and in the presence of Tetra Tech. Tetra Tech will not be held liable for any changes made to this document without written approval of Tetra Tech.

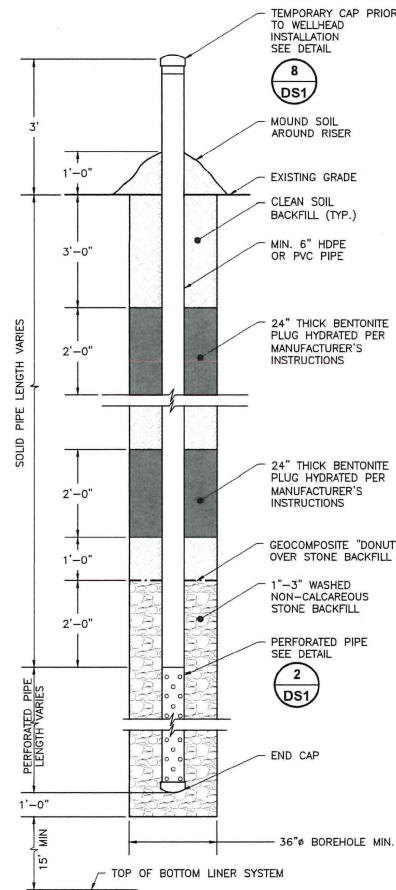

EXTRACTION WELL
DETAIL 1
SCALE: NOT TO SCALE DS1

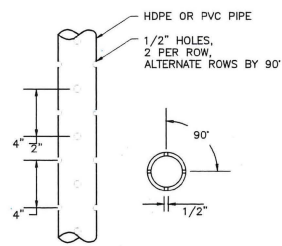

PERFORATED PIPE
DETAIL 2
SCALE: NOT TO SCALE DS1

- NOTES:**
1. PERFORATIONS SPACED 90° APART HORIZONTALLY.
 2. PERFORATIONS SPACED 4\"/>

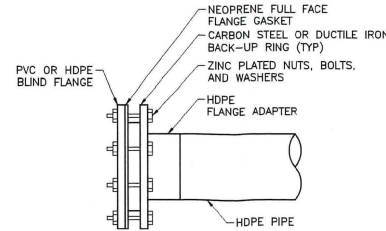

BLIND FLANGE ASSEMBLY
DETAIL 3
SCALE: NOT TO SCALE DS1

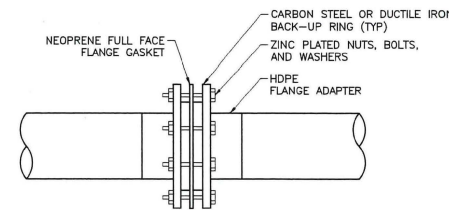

FLANGE CONNECTION
DETAIL 4
SCALE: NOT TO SCALE DS1

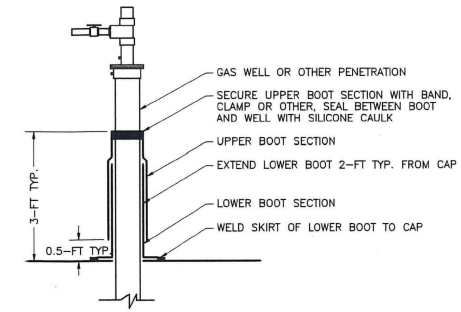

EXTRACTION WELL AND VERTICAL PIPE PENETRATION BOOT
DETAIL 5
SCALE: NOT TO SCALE DS1

- NOTE:**
1. WELL SEAL IS TO BE INSTALLED ON WELLS AND VERTICAL PIPE PENETRATIONS IN FINAL CAPPED AREAS.



ISOLATION VALVE
DETAIL 7
SCALE: NOT TO SCALE DS1

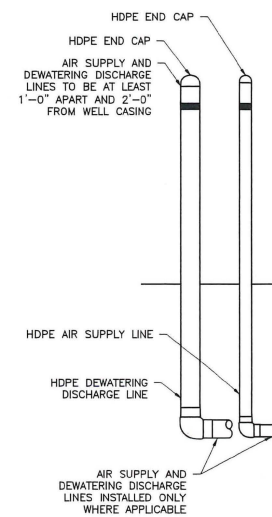

WELLHEAD
DETAIL 8
SCALE: NOT TO SCALE DS1

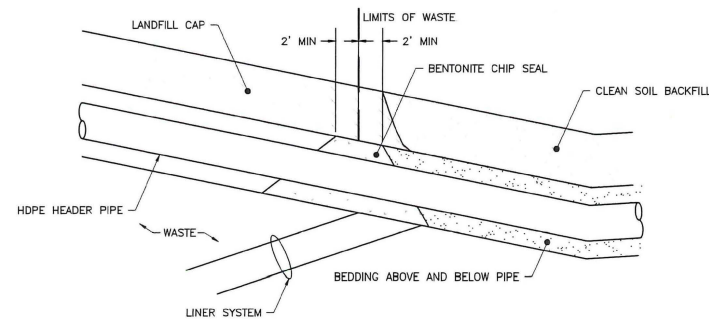

ANTI-SEEP COLLAR
DETAIL 6
SCALE: NOT TO SCALE DS1

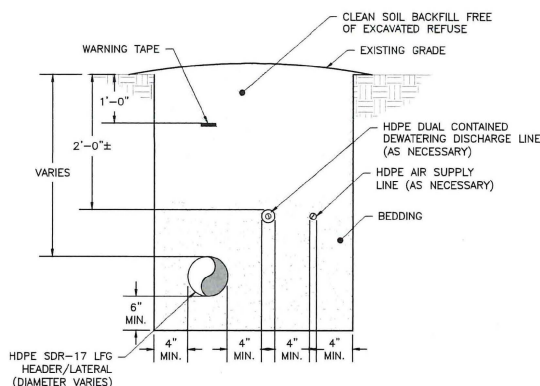

HEADER/LATERAL TRENCH INSTALLED OUTSIDE LIMITS OF WASTE
DETAIL 10
SCALE: NOT TO SCALE DS1

- NOTES:**
1. WARNING TAPE SHALL BE MIN. 3\"/>

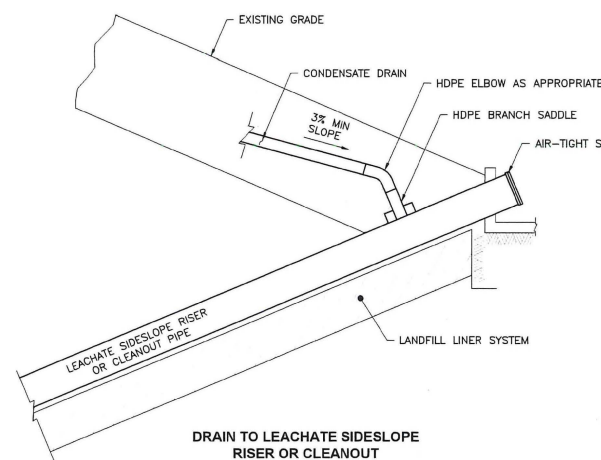

DRAIN TO LEACHATE SIDESLOPE RISER OR CLEANOUT
DETAIL 11
SCALE: NOT TO SCALE DS1

- NOTES:**
1. FIELD FIT CONDENSATE CONNECTION TO EXISTING LEACHATE RISER. RISER SIZE VARIES (6\"/>

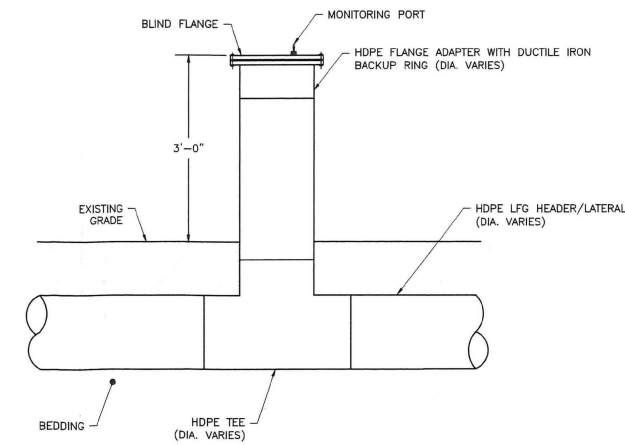

HEADER ACCESS RISER
DETAIL 12
SCALE: NOT TO SCALE DS1

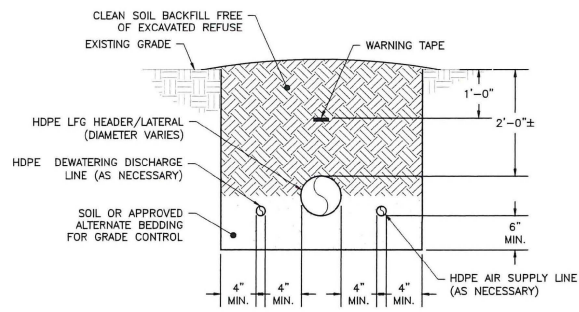

HEADER AND LATERAL PIPELINE TRENCH
DETAIL 9
SCALE: NOT TO SCALE DS1

- NOTES:**
1. WARNING TAPE SHALL BE MIN. 3\"/>



NOTE:
LAYOUT OF COMPONENTS AND DETAILS OF CONSTRUCTION ARE TYPICAL AND MAY VARY TO ACCOMMODATE FIELD CONDITIONS AND AVAILABLE TECHNOLOGY AT THE TIME OF CONSTRUCTION.

REV	DATE	DESCRIPTION	DESIGNED BY	CHECKED BY	APP. BY
1	5/1/23		NJL	JFS	KM

TETRA TECH

GFL ENVIRONMENTAL, INC.
BRENT RUN LANDFILL
MONTROSE TWP., GENESEE COUNTY, MICHIGAN

LANDFILL GAS COLLECTION AND CONTROL SYSTEM DETAILS

SHEET NO. **DS1**
PROJECT NO. 209-4231207

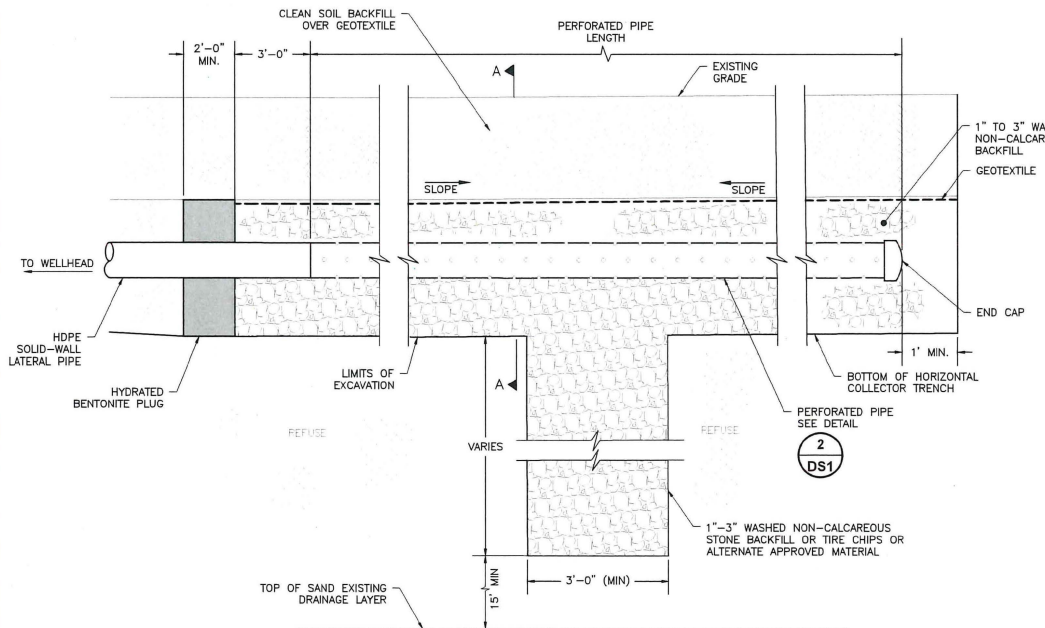

INTERIM HORIZONTAL COLLECTOR
DETAIL 1
 SCALE: NOT TO SCALE DS2

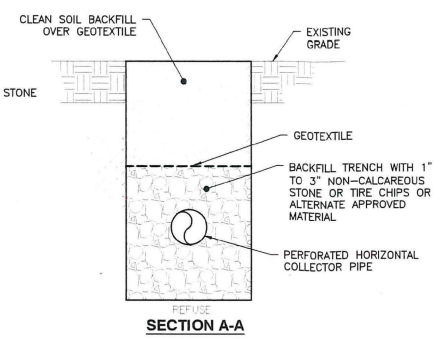

SECTION A-A

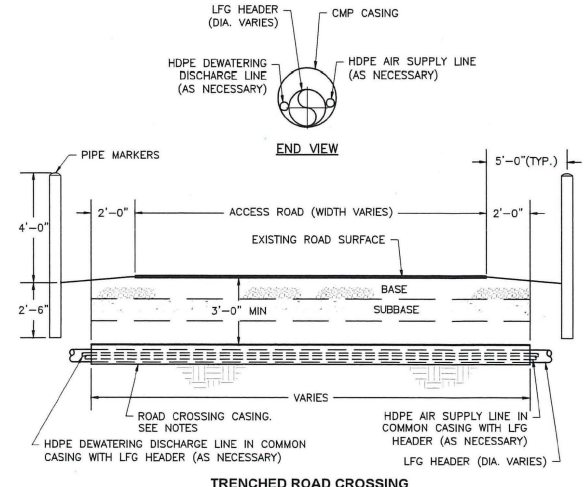

TRENCHED ROAD CROSSING
DETAIL 2
 SCALE: NOT TO SCALE DS2

- NOTES:**
1. ROAD SHALL BE RESTORED TO MATCH ORIGINAL CONDITIONS.
 2. CMP CASING A MINIMUM OF 5" GREATER THAN THE CUMULATIVE DIAMETER OF THE PIPES ENCASED.
 3. NUMBER AND TYPES OF PIPES ENCASED IN ROAD CROSSING VARIES.

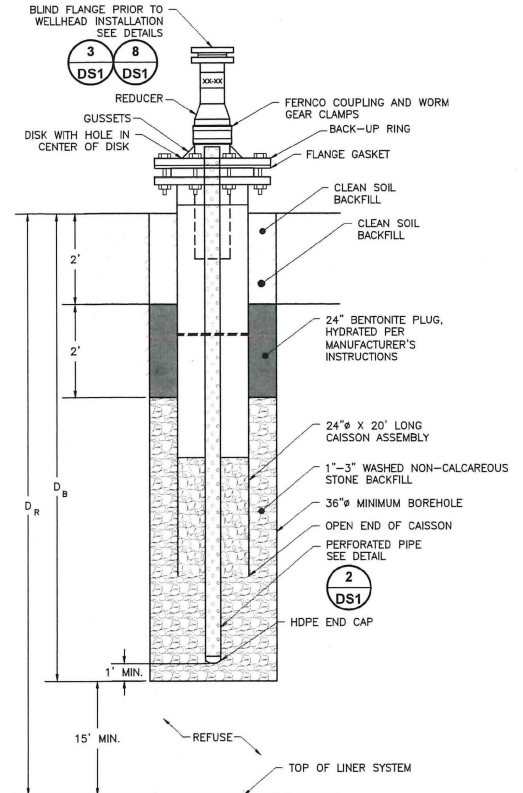

LFG EXTRACTION WELL WITH CAISSON
DETAIL 3
 SCALE: NOT TO SCALE DS2

- NOTES:**
1. D_r = DEPTH OF REFUSE
D_b = DEPTH OF BORING
 2. MINIMUM 15 FEET SEPARATION BETWEEN BASE OF BORING AND TOP OF LINER SYSTEM.

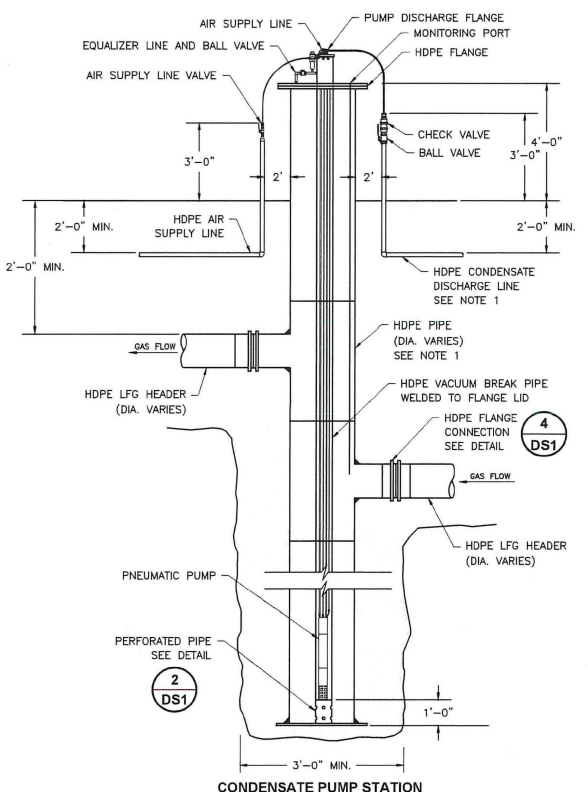

CONDENSATE PUMP STATION
DETAIL 5
 SCALE: NOT TO SCALE DS2

- NOTES:**
1. CONDENSATE PUMP STATIONS AND CONDENSATE DISCHARGE LINES INSTALLED OUTSIDE OF LIMITS OF WASTE SHALL BE DUAL CONTAINED.

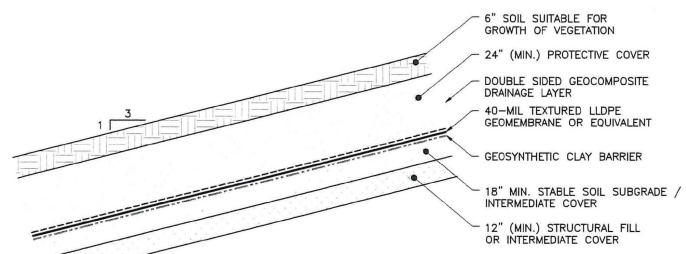

TYPICAL FINAL COVER
DETAIL 4
 SCALE: NOT TO SCALE DS2

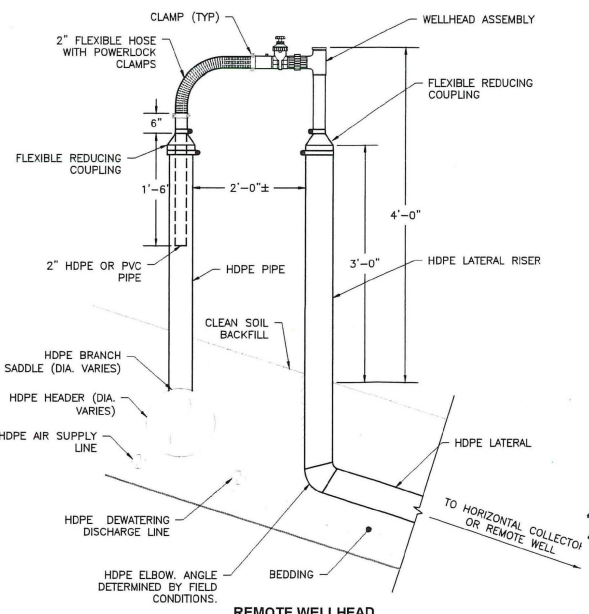

REMOTE WELLHEAD
DETAIL 6
 SCALE: NOT TO SCALE DS2

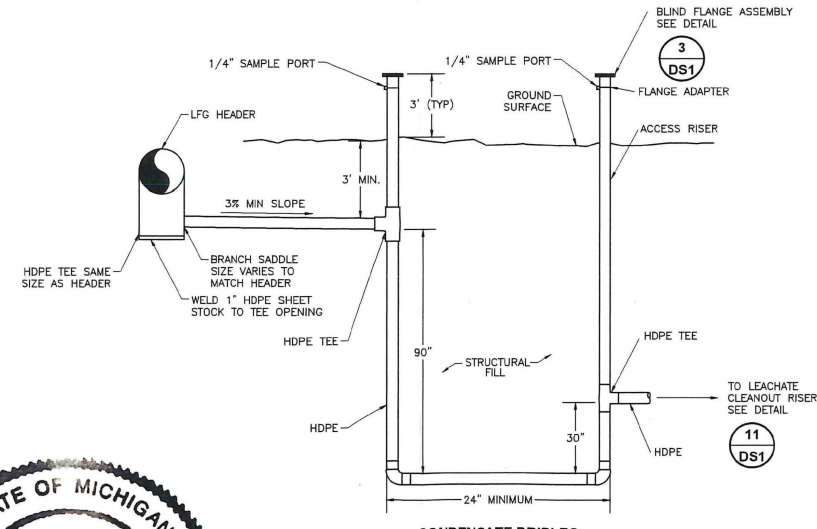

CONDENSATE DRIPLEG
DETAIL 7
 SCALE: NOT TO SCALE DS2

- NOTES:**
1. DRIPLEG DESIGNED FOR 60" W.C. APPLIED VACUUM.
 2. FILL DRIPLEG WITH CLEAN WATER PRIOR TO OPERATION.

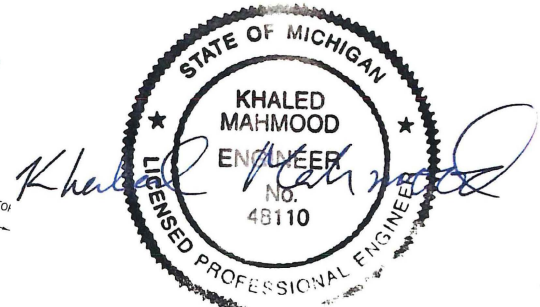

REV	DATE	DESCRIPTION	OWN BY	DES BY	CHK BY	APP BY



GFL ENVIRONMENTAL, INC.
 BRENT RUN LANDFILL
 MONTROSE TWP., GENESEE COUNTY, MICHIGAN
LANDFILL GAS COLLECTION AND CONTROL SYSTEM
DETAILS

SHEET NO.
DS2
 PROJECT NO.
 209-4231207

NOTE:
 LAYOUT OF COMPONENTS AND DETAILS OF CONSTRUCTION ARE TYPICAL AND MAY VARY TO ACCOMMODATE FIELD CONDITIONS AND AVAILABLE TECHNOLOGY AT THE TIME OF CONSTRUCTION.

This drawing represents intellectual property of Tetra Tech. Any modification to the original by other than Tetra Tech shall be approved by the original author and in such a manner that Tetra Tech will not be held liable for any design errors. In the absence of such approval, Tetra Tech shall not be held liable for any design errors.

1/2" = 0'
 1" = 0'
 2" = 0'
 3" = 0'
 4" = 0'
 5" = 0'
 6" = 0'
 7" = 0'
 8" = 0'
 9" = 0'
 10" = 0'
 11" = 0'
 12" = 0'
 13" = 0'
 14" = 0'
 15" = 0'
 16" = 0'
 17" = 0'
 18" = 0'
 19" = 0'
 20" = 0'
 21" = 0'
 22" = 0'
 23" = 0'
 24" = 0'
 25" = 0'
 26" = 0'
 27" = 0'
 28" = 0'
 29" = 0'
 30" = 0'
 31" = 0'
 32" = 0'
 33" = 0'
 34" = 0'
 35" = 0'
 36" = 0'
 37" = 0'
 38" = 0'
 39" = 0'
 40" = 0'
 41" = 0'
 42" = 0'
 43" = 0'
 44" = 0'
 45" = 0'
 46" = 0'
 47" = 0'
 48" = 0'
 49" = 0'
 50" = 0'
 51" = 0'
 52" = 0'
 53" = 0'
 54" = 0'
 55" = 0'
 56" = 0'
 57" = 0'
 58" = 0'
 59" = 0'
 60" = 0'
 61" = 0'
 62" = 0'
 63" = 0'
 64" = 0'
 65" = 0'
 66" = 0'
 67" = 0'
 68" = 0'
 69" = 0'
 70" = 0'
 71" = 0'
 72" = 0'
 73" = 0'
 74" = 0'
 75" = 0'
 76" = 0'
 77" = 0'
 78" = 0'
 79" = 0'
 80" = 0'
 81" = 0'
 82" = 0'
 83" = 0'
 84" = 0'
 85" = 0'
 86" = 0'
 87" = 0'
 88" = 0'
 89" = 0'
 90" = 0'
 91" = 0'
 92" = 0'
 93" = 0'
 94" = 0'
 95" = 0'
 96" = 0'
 97" = 0'
 98" = 0'
 99" = 0'
 100" = 0'