

**Air Emissions Test
of
No. 1 Biofilter**

Decorative Panels International



RECEIVED

NOV 13 2017

AIR QUALITY DIVISION

416 Ford Avenue
Alpena, Michigan

State Registration No. B1476

Prepared for

Decorative Panels International
Alpena, Michigan

November 10, 2017

Bureau Veritas Project No. 11017-000100.02



**BUREAU
VERITAS**

Move Forward with Confidence

Bureau Veritas North America, Inc.
22345 Roethel Drive
Novi, Michigan 48375
248.344.2661
www.us.bureauveritasHSE.com



RECEIVED

NOV 13 2017

AIR QUALITY DIVISION

Executive Summary

Decorative Panels International, Inc. retained Bureau Veritas North America, Inc. to test air emissions from the No. 1 Biofilter source at their hardboard manufacturing facility in Alpena, Michigan. The No. 1 Biofilter controls emissions from the No. 1 Board Press, and cooler (EUPRESS2S). The source is grouped in the permit within the FGPRESES and FGMACTDDDD flexible groups.

The objective of the testing was to evaluate compliance of the No. 1 Biofilter source with emission limits and requirements in:

- Michigan Department of Environmental Quality (MDEQ) Renewable Operating Permit (ROP) MI-ROP-B1476-2015a, effective December 21, 2015, for the FGMACTDDDD sources, and
- 40 CFR 63, Subpart DDDD, "National Emission Standards for Hazardous Air Pollutants: Plywood and Composite Wood Products."

Bureau Veritas measured total hydrocarbons (THC), methanol, and formaldehyde at the inlet and outlet of the No. 1 Biofilter control device.

Three 60-minute compliance test runs were performed under normal operating conditions following United States Environmental Protection Agency (USEPA) Methods 1, 2, 3, 25A, and 320.

Detailed results are presented in Table 1 after the Tables Tab of this report. The following table summarizes the results of the testing conducted on October 12, 2017.



No. 1 Biofilter Formaldehyde, Methanol, and THC Results

Parameter	Unit	Run 1	Run 2	Run 3	Average
Formaldehyde inlet concentration	ppmvw	23.7	25.9	25.8	25.1
Formaldehyde inlet emission rate	lb/hr	6.4	6.8	6.8	6.7
Formaldehyde outlet concentration	ppmvw	1.92	2.17	2.19	2.1
Formaldehyde outlet emission rate	lb/hr	0.63	0.66	0.68	0.66
Formaldehyde removal efficiency	%	90	90	90	90
Methanol inlet concentration	ppmvw	46.4	47.2	45.8	46.5
Methanol inlet emission rate	lb/hr	13.5	13.2	12.9	13.2
Methanol outlet concentration	ppmvw	12.5	18.2	16.0	15.6
Methanol outlet concentration	lb/hr	4.4	5.9	5.3	5.2
Methanol removal efficiency	%	67	55	59	61
THC inlet concentration as carbon	ppmvw	455.9	394.8	360.8	403.8
THC inlet emission rate as carbon	lb/hr	49.6	41.4	38.1	43.0
THC outlet concentration as carbon	ppmvw	61.9	68.4	60.4	63.6
THC outlet emission rate as carbon	lb/hr	8.2	8.3	7.5	8.0
THC removal efficiency as carbon	%	84	80	80	81

Note: The average biofilter bed temperature during the three test runs was 83°F.

The results of the emissions testing established the following:

- The No. 1 Biofilter source complies with the formaldehyde destruction efficiency limit of 90% or greater.



1.0 Introduction

1.1 Summary of Test Program

Decorative Panels International, Inc. retained Bureau Veritas North America, Inc. to test air emissions from the No. 1 Biofilter source at their hardboard manufacturing facility in Alpena, Michigan. The No. 1 Biofilter controls emissions from the No. 1 Board Press, and cooler (EUPRESS2S). The source is grouped in the permit within the FGPRESES and FGMACTDDDD flexible groups.

The objective of the testing was to evaluate compliance of the No. 1 Biofilter source with emission limits and requirements in:

- Michigan Department of Environmental Quality (MDEQ) Renewable Operating Permit (ROP) MI-ROP-B1476-2015a, effective December 21, 2015, for the FGMACTDDDD sources, and
- 40 CFR 63, Subpart DDDD, “National Emission Standards for Hazardous Air Pollutants: Plywood and Composite Wood Products.”

Bureau Veritas measured total hydrocarbons (THC), methanol, and formaldehyde at the inlet and outlet of the No. 1 Biofilter control devices on October 12, 2017.

Three 60-minute compliance test runs were performed under normal operating conditions following United States Environmental Protection Agency (USEPA) Methods 1, 2, 3, 25A, and 320.

1.2 Key Personnel

The key personnel involved in this test program are listed in Table 1-1 on the following page. Mr. David Kawasaki, Air Quality Consultant II with Bureau Veritas, led the emission testing. Mr. Bob Budnik, former Corporate Environmental Manager with Decorative Panels International, Inc., provided process coordination and recorded operating parameters. Ms. Becky Radulski and Mr. Jeremy Howe, Environmental Quality Analysts with MDEQ, witnessed the testing.



2.0 Source and Sampling Locations

2.1 Process Description

Decorative Panels International, Inc. produces a variety of hardboard products including wall paneling, pegboard, and marker board. Hardwood chips, such as aspen, ash, maple, and beech chips, are purchased and stored in an outdoor raw material storage area and reclaimed into silos. The wood chips are cooked and softened in one of four digesters using steam injection and ground into wood pulp fibers.

The pulp fibers are conveyed to a forming machine, which forms a mat of un-pressed hardboard. The mats are processed through a Coe dryer and cut using a trimmer and panel brush. The mats are conveyed to one of two hardboard lines, Line 1 or 3. Line 2 was historically operated but has since been decommissioned.

On the hardboard lines, the mats enter a predryer, a press, cooler, and tempering area. The predryer ensures the mat has the desired moisture content before the mat enters presses that heat and form hardboard. The hardboard is coated with linseed or Oxi-Cure® oil in the tempering area. The oil tempers the board thereby increasing its strength and “paintability.” The hardboard is humidified to approximate atmospheric conditions to limit warping. The boards are inspected, graded, cut, and packed for shipping.

The No. 1 Biofilter controls emissions from the No. 1 Board Press and cooler.

2.2 Process Operating Parameters

The process was operated under normal operating conditions during testing. The facility was manufacturing ¼-inch thick board at the No. 1 Board Press. For a standard production schedule under normal operating conditions, the rated capacity of the EUPRESS2S is 580 to 620 thousand square feet per day (24.2 to 25.8 thousand square feet per hour).

Table 2-1 summarizes the number of press loads, boards, and production based on the number of THC concentration peaks that were measured during the test periods.

Refer to Appendix E for process data recorded during testing.



Table 2-1
Summary of EUPRESS2S Production Data

Test Run	Press Loads	Boards Pressed	Production Rate
			msf/hour
1	19	380	24.32
2	20	400	25.60
3	18	360	23.04
Average	19	380	24.32

msf: thousand square feet

2.3 Control Equipment

Gaseous emissions from the No. 1 Board Press are controlled by a DynaWave Engineering water scrubber and the No. 1 Biofilter. Emissions from the No. 1 Board Press are captured by a permanent total enclosure that surrounds the press area. The air from the enclosure continuously exhausts through a duct that exits the roof of the building and flows towards the pollution control equipment. The captured air (flue gas) enters the top of the scrubber and flows downwards in the vessel. Inside the vessel, water (containing sodium hydroxide to maintain a neutral pH) is sprayed into the air to remove particulates and humidify the air before the air enters the biofilter. The water is sprayed onto a series of chevrons to increase the air-to-water contact surface area.

As the flue gas mixes with the water, particulates and other pollutants are removed. The water drains to the bottom of the vessel and a portion is recirculated into the system with the remaining portion discharged to the onsite water treatment system. The flue gas exits the top of the scrubber and flows into the No. 1 Biofilter.

The No. 1 Biofilter, manufactured by Monsanto Enviro-Chem., consists of six compartments. The air from the scrubber can be heated by a heat exchanger before being directed into the six-biobed compartments. The compartments contain water sprayers to maintain a moist environment, and layers of Douglas-fir bark from the western United States. The Douglas-fir bark provides an environment where biologically active microbes can oxidize and remove the contaminants.

After passing through the bark, the flue gas is drawn into fans that discharge the gas through the stack, SVS2COOLR-STK28.

The biofilter bed temperatures are continuously monitored by multiple thermocouples in each chamber. These temperatures are reduced to 15-minute averages and recorded by the facility.



The No. 1 Biofilter average bed temperatures during testing are presented in Table 2-2. Refer to Appendix E for facility operating data.

Table 2-2
No. 1 Biofilter Bed Average Temperature During Testing

Test Run	Minimum 15-minute Temperature (°F)	Maximum 15-minute Temperature (°F)	Average Temperature (°F)
1	84	86	85
2	82	83	83
3	80	81	81
Average	82	83	83

2.4 Flue Gas Sampling Locations

Figures 2-1 and 2-2 provide photographs that show the sampling ports for the No. 1 Biofilter sampling locations. Appendix Figures 1 and 2 present the No. 1 Biofilter inlet and outlet sampling ports and traverse point locations.

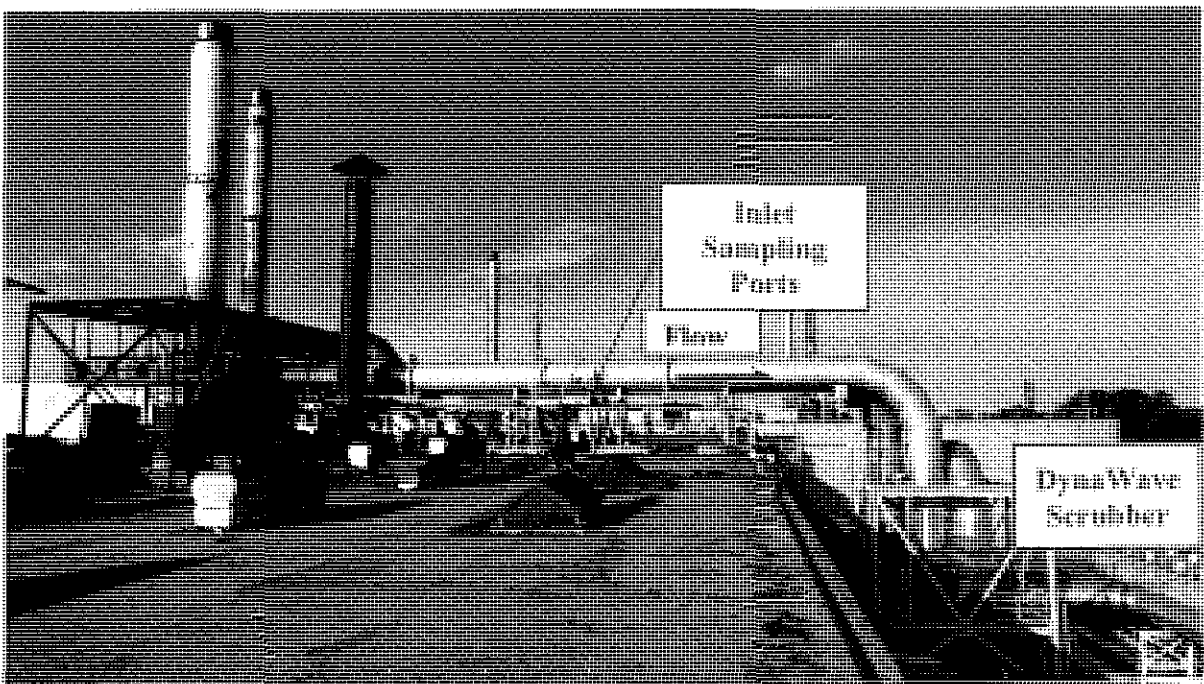

Figure 2-1. No. 1 Biofilter Inlet Sampling Location

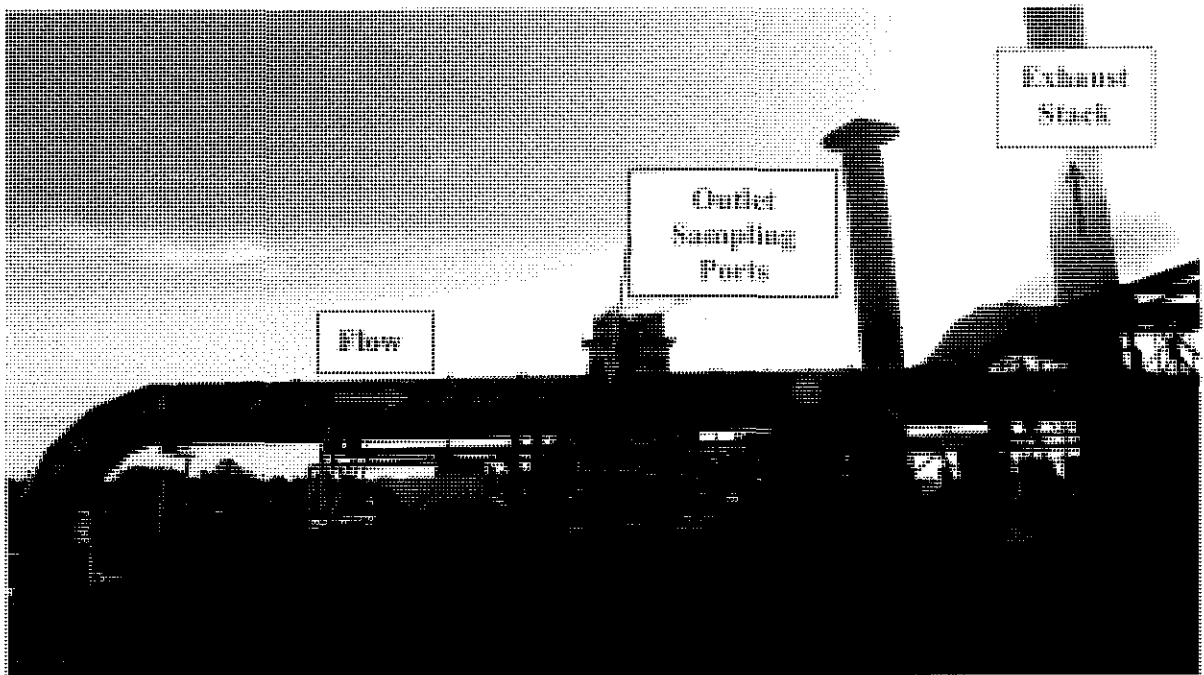

Figure 2-2. No. 1 Biofilter Outlet Sampling Location



2.5 Process Sampling Locations

Process sampling was not required during this test program. A process sample is a sample that is analyzed for operational parameters, such as calorific value of a fuel (e.g., natural gas, coal), organic compound content (e.g., paint coatings), or composition (e.g., polymers).



3.0 Summary and Discussion of Results

3.1 Objectives and Test Matrix

The objective of the testing was to satisfy testing requirements and evaluate compliance of the No. 1 Biofilter source with emission limits and requirements in:

- MDEQ ROP: MI-ROP-B1476-2015a, effective December 21, 2015, for the FGMACTDDDD sources, and
- 40 CFR 63, Subpart DDDD, “National Emission Standards for Hazardous Air Pollutants: Plywood and Composite Wood Products.”

Compliance with the FGMACTDDDD total hazardous air pollutant (HAP) permit limits, based on the use of an add-on control device, can be demonstrated by any one of the following criteria:

1. 90% reduction of total HAP mass emission rate, measured as THC, as carbon.
2. Total HAP concentration less than 20 part per million by volume, dry (ppmvd), measured as THC (as carbon).
3. Total HAP reduction so that methanol mass emission rate is reduced by 90%.
4. Total HAP reduction so that methanol concentration is less than 1 ppmvd, if the uncontrolled methanol concentration entering the control device is greater than 10 ppmvd.
5. Total HAP reduction so that formaldehyde mass emission rate is reduced by 90%.
6. Total HAP reduction so that formaldehyde concentration is less than 1 ppmvd, if the uncontrolled formaldehyde entering the control device is greater than 10 ppmvd.

Bureau Veritas measured THC, methanol, and formaldehyde at the inlet and outlet stack of No.1 Biofilter. Table 3-1 summarizes the sampling and analytical test matrix.



RECEIVED

NOV 13 2017

~~AIR QUALITY DIVISION~~

**Table 3-1
Sampling and Analytical Matrix**

Sampling Location	Sample/ Type of Pollutant	Sample Method	Date (2017)	Run	Start Time	End Time	Analytical Method	Analytical Laboratory	Comment
Inlet and Outlet of No. 1 Biofilter	Flowrate, molecular weight, moisture content, formaldehyde, methanol, total hydrocarbons	EPA 1, 2, 3, 25A, 320	Oct 12	1	10:07	11:06	Pitot tube, chemical absorption analyzer, flame ionization analyzer, Fourier transform infrared analyzer	Bureau Veritas	Compliance tests
				2	11:44	12:43			
				3	13:56	14:55			

3.2 Field Test Changes and Issues

The testing was performed in accordance with USEPA procedures, during normal operating conditions, as outlined in the Intent-to-Test Plan submitted to MDEQ on July 26, 2017, and approved on August 4, 2017.

No field test changes or issues were encountered during the test program, with the exception that the No. 1 Biofilter testing date was first moved to September 13, 2017, due to the production material deficiency on the original test date, and was then rescheduled to October 12, 2017 due to unanticipated operational issues encountered on September 13, 2017.

3.3 Summary of Results

Detailed results are presented in Table 1 after the Tables Tab of this report. The results of the testing are presented in Table 3-2.



**Table 3-2
No. 1 Biofilter Formaldehyde, Methanol, and THC Results**

Parameter	Unit	Run 1	Run 2	Run 3	Average
Formaldehyde inlet concentration	ppmvd	23.7	25.9	25.8	25.1
Formaldehyde inlet emission rate	lb/hr	6.4	6.8	6.8	6.7
Formaldehyde outlet concentration	ppmvd	1.92	2.17	2.19	2.1
Formaldehyde outlet emission rate	lb/hr	0.63	0.66	0.68	0.66
Formaldehyde removal efficiency	%	90	90	90	90
Methanol inlet concentration	ppmvd	46.4	47.2	45.8	46.5
Methanol inlet emission rate	lb/hr	13.5	13.2	12.9	13.2
Methanol outlet concentration	ppmvd	12.5	18.2	16.0	15.6
Methanol outlet concentration	lb/hr	4.4	5.9	5.3	5.2
Methanol removal efficiency	%	67	55	59	61
THC inlet concentration as carbon	ppmvd	455.9	394.8	360.8	403.8
THC inlet emission rate as carbon	lb/hr	49.6	41.4	38.1	43.0
THC outlet concentration as carbon	ppmvd	61.9	68.4	60.4	63.6
THC outlet emission rate as carbon	lb/hr	8.2	8.3	7.5	8.0
THC removal efficiency as carbon	%	84	80	80	81

Note: The average biofilter bed temperature during the three test runs was 83°F.

The results of the emissions testing established the following:

- The No. 1 Biofilter source complies with the formaldehyde destruction efficiency limit of 90% or greater.



4.0 Sampling and Analytical Procedures

Bureau Veritas measured emissions following the guidelines and procedures specified in 40 CFR 51, Appendix M, "Recommended Test Methods for State Implementation Plans," 40 CFR 60, Appendix A, "Standards of Performance for New Stationary Sources," 40 CFR 63, Appendix A, "Test Methods Pollutant Measurement Methods from Various Waste Media," and State of Michigan Part 10 Rules, "Intermittent Testing and Sampling." Table 4-1 outlines the test methods for the test parameters, including ancillary measurements required by the USEPA methods (i.e., traverse point selection, velocity, molecular weight, and moisture content).

**Table 4-1
Emission Test Parameters**

Parameter	Source		USEPA Reference	
	Inlet of No. 1 Biofilter	Outlet of No. 1 Biofilter	Method	Title
Sampling ports and traverse points	•	•	1	Sample and Velocity Traverses for Stationary Sources
Velocity and flowrate	•	•	2	Determination of Stack Gas Velocity and Volumetric Flow Rate (Type S Pitot Tube)
Molecular weight	•	•	3	Gas Analysis for the Determination of Dry Molecular Weight
Total hydrocarbons	•	•	25A	Determination of Total Gaseous Organic Concentration using a Flame Ionization Analyzer
Gas dilution calibration	•	•	205	Verification of Gas Dilution Systems for Field Instrument Calibrations
Formaldehyde, methanol, and moisture content	•	•	320	Measurement of Vapor Phase Organic and Inorganic Emissions by Extractive Fourier Transform Infrared (FTIR) Spectroscopy

4.1 Emission Test Methods

4.1.1 Volumetric Flowrate (USEPA Methods 1 and 2)

Method 1, "Sample and Velocity Traverses for Stationary Sources," from the Code of Federal Regulations, Title 40, Part 60 (40 CFR 60), Appendix A, was used to evaluate the sampling location, the number of traverse points for sampling, and the measurement of velocity profiles. Details of the sampling location and number of velocity traverse points are presented in Table 4-2.



**Table 4-2
Sampling Location and Number of Traverse Points**

Source	Sampling Location	Duct Diameter (inches)	Distance from Ports to Upstream Flow Disturbance (diameters)	Distance from Ports to Downstream Flow Disturbance (diameters)	Number of Ports Used	Traverse Points per Port	Total Traverse Points	Cyclonic Flow Null Angle (°)
No. 1 Biofilter	Inlet	59.75	8.8	8.0	2	12	24	0
No. 1 Biofilter	Outlet	59.25	7.6	3.4	2	12	24	0

Figures 2-1 and 2-2 are photographs depicting the sampling locations at the No. 1 Biofilter sources. Appendix Figures 1 and 2 present the No. 1 Biofilter's inlet and outlet sampling ports and traverse point locations.

Method 2, "Determination of Stack Gas Velocity and Volumetric Flow Rate (Type S Pitot Tube)," was used to measure flue gas velocity and calculate volumetric flowrate. S-type Pitot tubes and thermocouple assemblies, calibrated in accordance with Method 2, Section 10.0, were used during testing. Because the dimensions of the Pitot tubes met the requirements outlined in Method 2, Section 10.1, and were within the specified limits, the baseline Pitot tube coefficient of 0.84 (dimensionless) was assigned. Refer to Appendix A for the Pitot tube inspection sheets.

Cyclonic Flow Check. Bureau Veritas evaluated whether cyclonic flow was present at the sampling locations. Cyclonic flow is defined as a flow condition with an average null angle greater than 20°. The direction of flow can be determined by aligning the Pitot tube to obtain zero (null) velocity head reading—the direction would be parallel to the Pitot tube face openings or perpendicular to the null position. By measuring the angle of the Pitot tube face openings in relation to the stack walls when a null angle is obtained, the direction of flow is measured. If the absolute average of the flow direction angles is greater than 20 degrees, the flue gas is considered cyclonic at that sampling location and an alternative location should be found.

The measurements summarized in Table 4-2 indicate the absence of cyclonic flow at the sampling locations. Field data sheets are included in Appendix C. Computer-generated field data sheets are included in Appendix D.

4.1.2 Molecular Weight (USEPA Method 3)

Molecular weight at the No. 1 Biofilter location was measured using USEPA Method 3, "Gas Analysis for the Determination of Dry Molecular Weight." Flue gas was extracted from the

stack through a probe positioned near the centroid of the duct and directed into a Fyrite® gas analyzer. The concentrations of carbon dioxide (CO₂) were measured by chemical absorption to within ±0.5%. The average CO₂ results of the grab samples were used to calculate molecular weight.

4.1.3 Total Hydrocarbons (USEPA Method 25A)

The THC sampling followed USEPA Method 25A, “Determination of Total Gaseous Organic Concentration Using a Flame Ionization Analyzer” procedures. Samples were collected through a stainless steel probe and heated sample line into the analyzer. Bureau Veritas used J.U.M. manufactured flame ionization detector based hydrocarbon analyzers.

A flame ionization detector (FID) determines the average hydrocarbon concentration in part per million by volume (ppmv) of THC as the calibration gas (i.e., propane). The FID is fueled by 100% hydrogen, which generates a flame with a negligible number of ions. Flue gas is introduced into the FID and enters the flame chamber. The combustion of flue gas generates electrically charged ions. The analyzer applies a polarizing voltage between two electrodes around the flame, producing an electrostatic field. Negatively charged ions, anions, migrate to a collector electrode, while positive charged ions, cations, migrate to a high-voltage electrode. The current between the electrodes is directly proportional to the hydrocarbon concentration in the sample. The flame chamber is depicted at right.

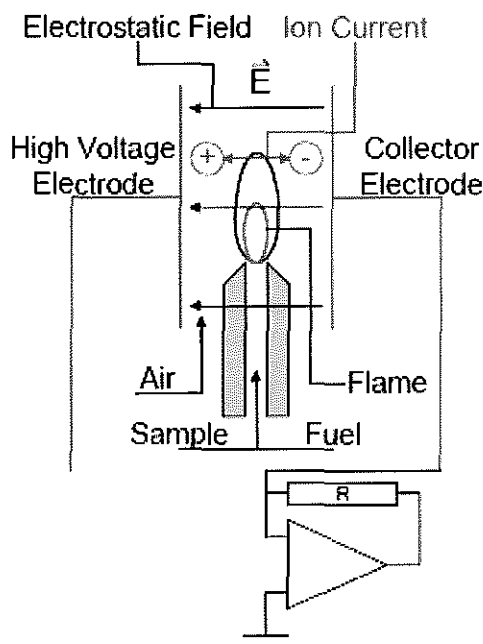

Figure 4-1. FID Flame Chamber

Using the voltage analog signal, measured by the FID, the concentration of total hydrocarbons is recorded by a data acquisition system (DAS). The average concentration of total hydrocarbons is reported as the calibration gas (i.e., propane) in equivalent units.

Before testing, the FID analyzers were calibrated by introducing a zero-calibration range gas (<1% of span value) and high-calibration range gas (80-90% span value) to the tip of the sampling probe. The span values were set to 1.5 to 2.5 times the expected concentration (e.g., 0-100 ppmv). Next, a low-calibration range gas (25-35% of span value) and mid-calibration range gas (45-55% of span value) were introduced. The analyzers were considered to be calibrated when the analyzer response was ±5% of the calibration gas value.

At the conclusion of a test run, a calibration drift test was performed by introducing the zero- and mid-calibration gases to the tip of the sampling probe. The test run data were considered valid if the calibration drift test demonstrated the analyzers responded within $\pm 3\%$ of calibration span from pre-test to post-test calibrations.

Figure 4-2 depicts the USEPA Method 25A sampling train.

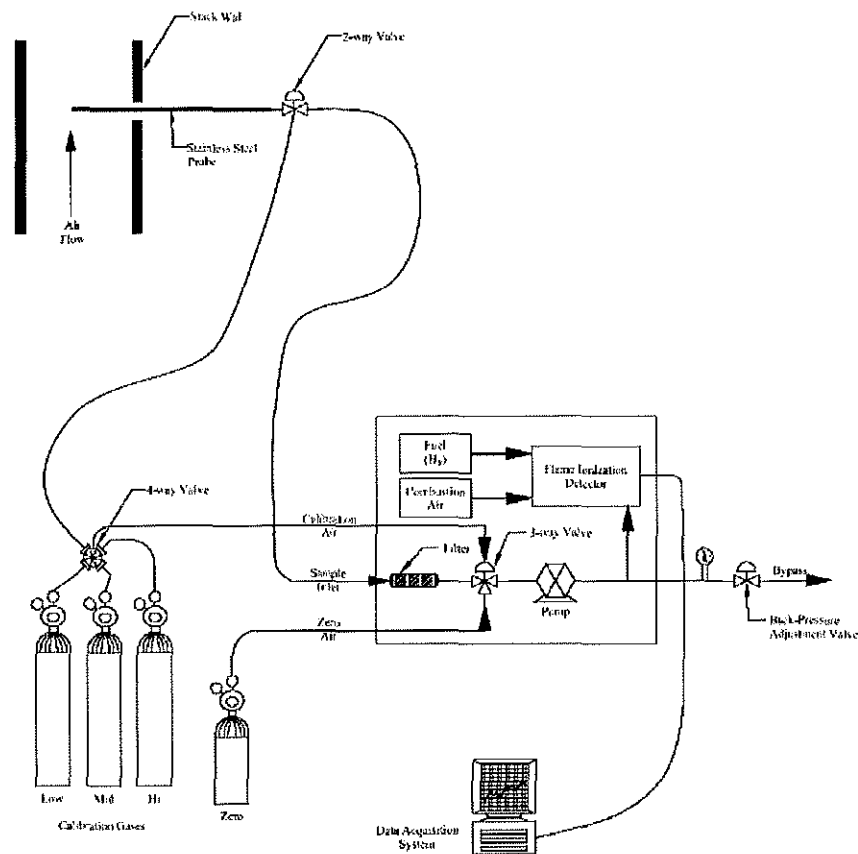

Figure 4-2. USEPA Method 25A Sampling Train

4.1.4 Formaldehyde, Methanol, and Moisture Content (USEPA Method 320)

Formaldehyde and methanol emissions and moisture content were measured in accordance with USEPA Method 320, "Measurements of Vapor Phase Organic and Inorganic Emissions by Extractive Fourier Transform Infrared (FTIR) Spectroscopy." Gaseous samples were withdrawn from the stack and transferred to MKS Instruments MultiGas 2030 FTIR spectrometers for formaldehyde and methanol measurements. Figure 4-3 depicts the USEPA Method 320 sampling train.



The samples were directed through a heated probe, heated filter and heated transfer line connected to the FTIR. The probes, filters, transfer lines, and FTIRs were maintained at 191° C (375° F) during testing. The formaldehyde and methanol concentrations were measured based on their infrared absorbance compared to reference spectra. The FTIR analyzer scans the sample approximately once per second. A data point consists of the co-addition of 64 scans, with a data point generated every minute.

FTIR quality assurance procedures followed USEPA Method 320. A calibration transfer standard (CTS) was analyzed before and after testing. Acetaldehyde and methanol analyte spiking was performed before the tests. Section 3.29 of USEPA Method 320 allows the use of a surrogate analyte for the purposes of analyte spiking. Acetaldehyde was chosen as surrogate to formaldehyde for the following reasons:

- The highest obtainable formaldehyde cylinder is 30 ppm: therefore, the spiked concentration would be 3 ppm (analyte spiking consists of sampling 1 part calibration gas in the presence of 9 parts effluent gas). The formaldehyde concentrations of the sources tested were much higher than 3 ppm.
- Acetaldehyde's physical and chemical properties are similar to those of formaldehyde. Formaldehyde is the C₁ aldehyde (CH₂O); acetaldehyde is the C₂ aldehyde (CH₃CHO).

The analyte spikes were set to a target dilution ratio of 1:10 or less. Valid tests required acetaldehyde and methanol spike recoveries to be within the Method 320 allowance of ±30%.

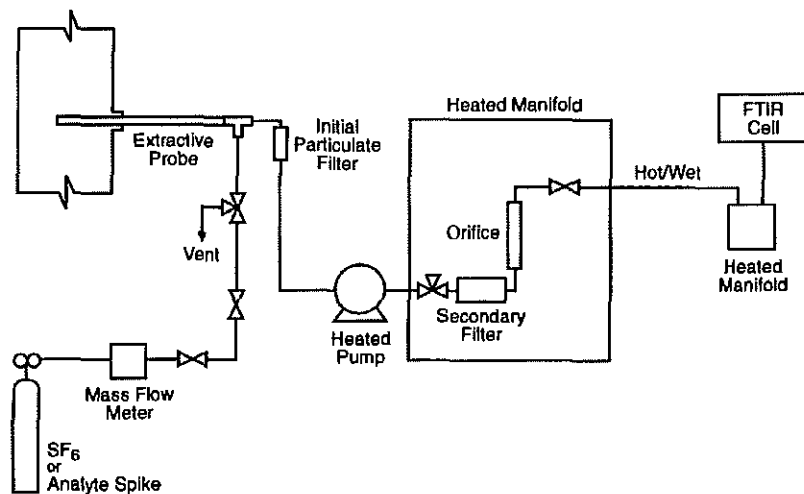

Figure 4-3. USEPA Method 320 Sample Train



4.1.5 Gas Dilution (USEPA Method 205)

A gas dilution system was used to introduce known values of calibration gases into the THC analyzers. The gas dilution system consisted of calibrated mass flow controllers. The system diluted a high-level calibration gas to within $\pm 2\%$ of predicted values. This gas divider was capable of diluting gases at various increments.

Before the start of testing, the gas divider dilutions were verified to be within $\pm 2\%$ of predicted values. Two sets of dilutions of the high-level calibration gas were performed. Subsequently, a certified mid-level calibration gas was introduced into the analyzer; the calibration gas concentration was within $\pm 10\%$ of a dilution. Table 4-3 presents the USEPA Method 205 gas dilution field verification measurements for the No.1 Biofilter.

**Table 4-3
No. 1 Biofilter Gas Dilution Field Verification**

Expected/Actual Concentration	Acceptable Range†		Actual Concentration 1	Actual Concentration 2	Actual Concentration 3	Acceptable Yes/No
	Low	High				
(ppmv)	(ppmv)	(ppmv)	(ppmv)	(ppmv)	(ppmv)	
1,500	1,470	1,530	1,478.9	1,476.9	1,475.8	Yes
3,000	2,940	3,060	3,011.9	3,047.6	3,042.2	Yes
3,001	2,941	3,061	3,058.0	3,054.9	3,057.1	Yes

† Acceptable range is $\pm 2\%$ of the expected concentration.

The field calibrations verified the accuracy of the gas dilution system. Refer to Appendix A for the calibration gas certifications and gas dilution field calibrations.

4.2 Procedures for Obtaining Process Data

Process data were recorded by Decorative Panels International, Inc. personnel during testing. The number of press loads was obtained from the number of THC concentration peaks recorded during testing. Refer to Sections 2.1 and 2.2 for discussions of process and control device data and Appendix E for the operating parameters recorded during testing.



5.0 QA/QC Activities

5.1 Pretest QA/QC Activities

Before testing, the sampling equipment was cleaned, inspected, and calibrated according to procedures outlined in the applicable USEPA sampling method and USEPA's "Quality Assurance Handbook for Air Pollution Measurement Systems, Volume and Principles" and, Volume III, "Stationary Source Specific Methods." Refer to Appendix A for inspection and calibration sheets.

5.2 QA/QC Audits

The results of select sampling and equipment QA/QC audits and the acceptable USEPA tolerance are presented in the following sections.

5.2.1 Instrument Analyzer QA/QC Audits

The FID and FTIR analyzers met the QA/QC requirements of USEPA Methods 25A and 320. The analyzers were calibrated using USEPA Traceability Protocol or Certified Standard calibration gases with an uncertainty $\pm 2\%$ of certified value. FID calibration error tests indicated the analyzers were responding to $\pm 5.0\%$ of the cylinder concentration and did not drift more than $\pm 3\%$ after each test run. The FTIR analyzers passed all QA/QC procedures including acetaldehyde and methanol spike recoveries within the $\pm 30\%$ allowance.

Refer to Appendix A for the calibration gas certificates and analyzer calibration data and Appendix F for the FTIR calibration data.

5.3 QA/QC Problems

QA/QC problems were not encountered during this test program.

RECEIVED
NOV 13 2017
AIR QUALITY DIVISION



Limitations

The information and opinions rendered in this report are exclusively for use by Decorative Panels International, Inc. Bureau Veritas North America, Inc. will not distribute or publish this report without Decorative Panels International, Inc.'s consent except as required by law or court order. The information and opinions are given in response to a limited assignment and should be implemented only in light of that assignment. Bureau Veritas North America, Inc. accepts responsibility for the competent performance of its duties in executing the assignment and preparing reports in accordance with the normal standards of the profession, but disclaims any responsibility for consequential damages.

This report prepared by: *David Kawasaki*
David Kawasaki, QSTI
Air Quality Consultant II
Health, Safety, and Environmental Services

This report reviewed by: *Derek R. Wong*
Derek R. Wong, Ph.D., P.E.
Director and Vice President
Health, Safety, and Environmental Services



Table 1
No. 1 Biofilter Compliance Results
Decorative Panels International, Inc.
Alpena, Michigan
Bureau Veritas Project No. 11017-000100.02
Sampling Date: October 12, 2017

Parameter		Units	Run 1	Run 2	Run 3	Average	
Sampling Time			10:07 - 11:06	11:44 - 12:43	13:56 - 14:55		
Duration		min	60	60	60		
Inlet	Average Gas Stream Volumetric Flowrate	scfm	58,152	56,090	56,375	56,872	
	Gas Stream Percent Moisture Content	%	1.8	1.8	1.8	1.8	
	Formaldehyde Concentration	ppmvw, as CH ₂ O	23.7	25.9	25.8	25.1	
	Formaldehyde Mass Emission Rate	lb/hr, as CH ₂ O	6.4	6.8	6.8	6.7	
	Methanol Concentration	ppmvw, CH ₃ OH	46.4	47.2	45.8	46.5	
	Methanol Mass Emission Rate	lb/hr, as CH ₃ OH	13.5	13.2	12.9	13.2	
	THC Concentration	ppmvw, as propane	152.0	131.6	120.3	134.6	
	THC Concentration	ppmvw, as carbon	455.9	394.8	360.8	403.8	
	THC Mass Emission Rate	lb/hr, as propane	60.6	50.6	46.5	52.6	
	THC Mass Emission Rate	lb/hr, as carbon	49.6	41.4	38.1	43.0	
	Outlet	Gas Stream Volumetric Flowrate	scfm	70,553	64,980	66,087	67,206
		Gas Stream Percent Moisture Content	%	3.5	3.4	3.4	3.4
		Formaldehyde Concentration	ppmvw, as CH ₂ O	1.9	2.2	2.2	2.1
Formaldehyde Mass Emission Rate		lb/hr, as CH ₂ O	0.63	0.66	0.68	0.66	
Methanol Concentration		ppmvw, CH ₃ OH	12.5	18.2	16.0	15.6	
Methanol Mass Emission Rate		lb/hr, as CH ₃ OH	4.4	5.9	5.3	5.2	
THC Concentration		ppmvw, as propane	20.6	22.8	20.1	21.2	
THC Concentration		ppmvw, as carbon	61.9	68.4	60.4	63.6	
THC Mass Emission Rate		lb/hr, as propane	10	10	9.1	9.8	
THC Mass Emission Rate		lb/hr, as carbon	8.2	8.3	7.5	8.0	
Formaldehyde Destruction Efficiency Results		%	90	90	90	90	
Methanol Destruction Efficiency Results		%	67	55	59	61	
No. 1 Biofilter THC Destruction Efficiency Results		%	84	80	80	81	

TRAVERSE POINT	DISTANCE FROM STACK WALL (INCHES)
1	1.3
2	4.0
3	7.1
4	10.6
5	14.9
6	21.3
7	38.5
8	44.8
9	49.2
10	52.7
11	55.7
12	58.5

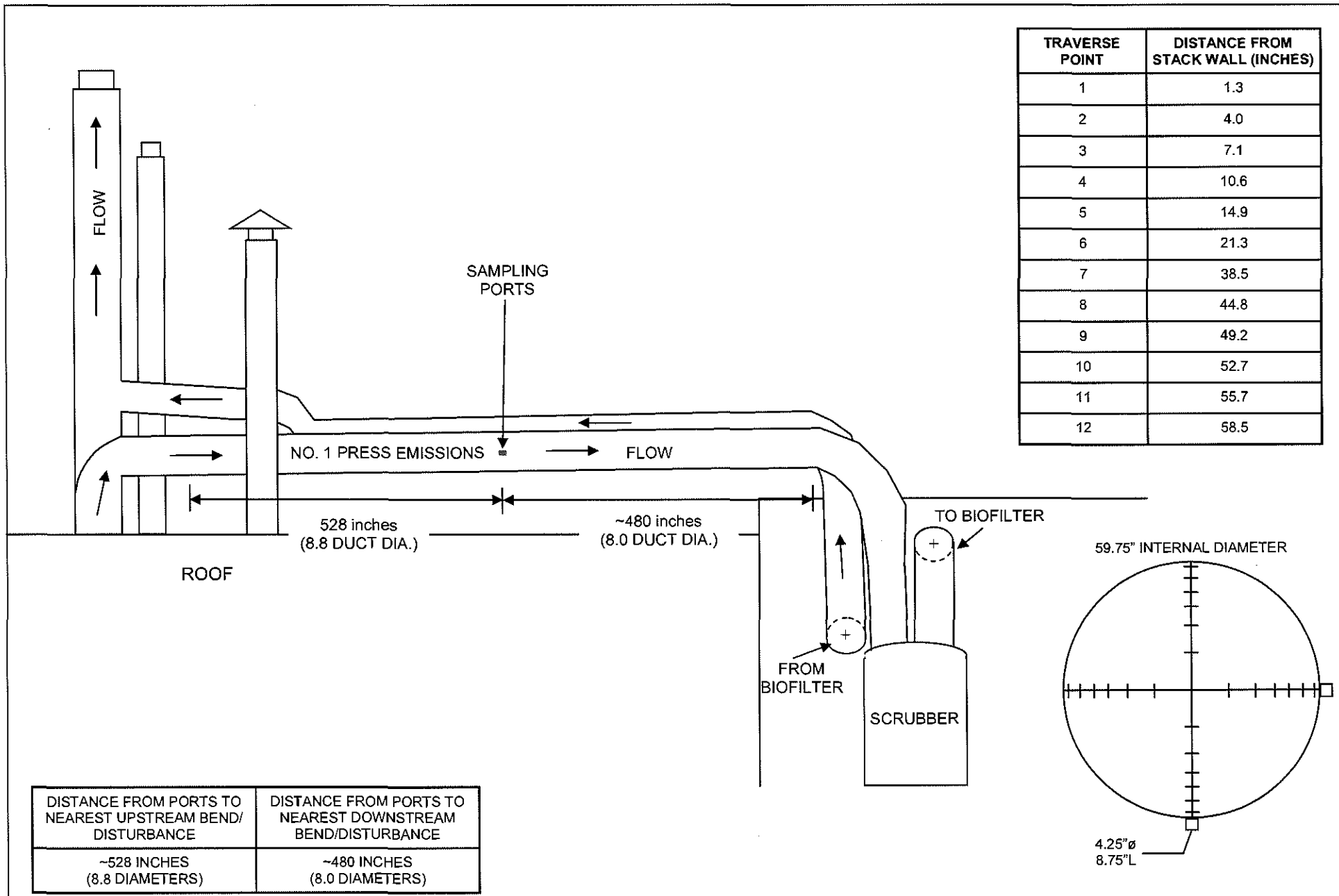

DISTANCE FROM PORTS TO NEAREST UPSTREAM BEND/DISTURBANCE	DISTANCE FROM PORTS TO NEAREST DOWNSTREAM BEND/DISTURBANCE
~528 INCHES (8.8 DIAMETERS)	~480 INCHES (8.0 DIAMETERS)

SCALE	NOT TO SCALE
DATE	October 16, 2017
PRJ NO.	11017-000100.02

NO. 1 BIOFILTER INLET SAMPLING PORTS AND TRAVERSE POINT LOCATIONS

DECORATIVE PANELS INTERNATIONAL, INC.
ALPENA, MICHIGAN



FIGURE

1

TRAVERSE POINT	DISTANCE FROM STACK WALL (INCHES)
1	1.2
2	4.0
3	7.0
4	10.5
5	14.8
6	21.1
7	38.2
8	44.4
9	48.8
10	52.3
11	55.3
12	58.0

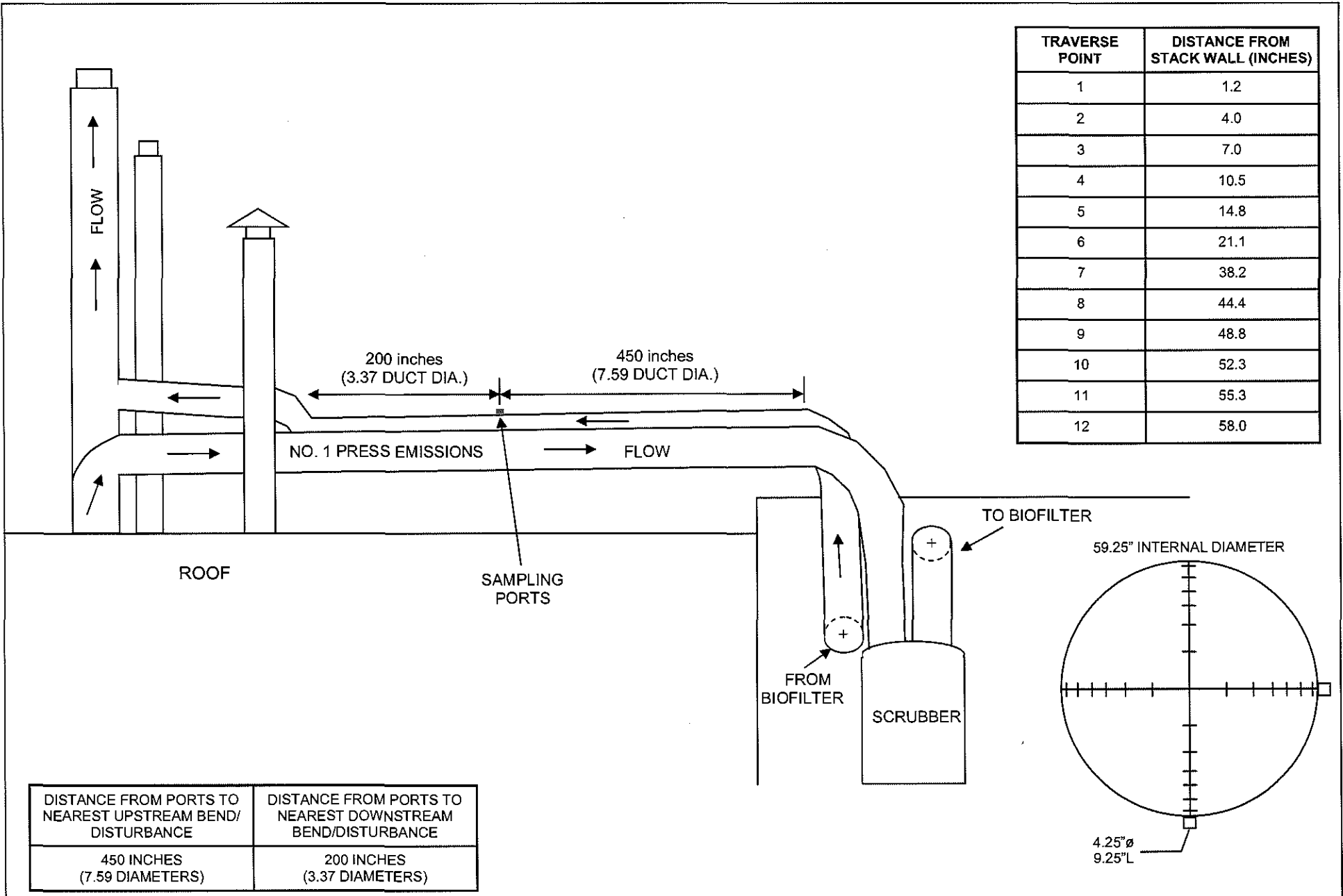

DISTANCE FROM PORTS TO NEAREST UPSTREAM BEND/DISTURBANCE	DISTANCE FROM PORTS TO NEAREST DOWNSTREAM BEND/DISTURBANCE
450 INCHES (7.59 DIAMETERS)	200 INCHES (3.37 DIAMETERS)

SCALE	NOT TO SCALE
DATE	October 16, 2017
PRJ NO.	11017-000100.02

NO. 1 BIOFILTER OUTLET SAMPLING PORTS AND TRAVERSE POINT LOCATIONS
 DECORATIVE PANELS INTERNATIONAL, INC.
 ALPENA, MICHIGAN





No. 1 Biofilter Inlet and Outlet Concentrations - Run 1
Decorative Panels International, Inc.
Alpena, Michigan
Bureau Veritas Project No. 11017-000100.02
Sampling Date: October 12, 2017

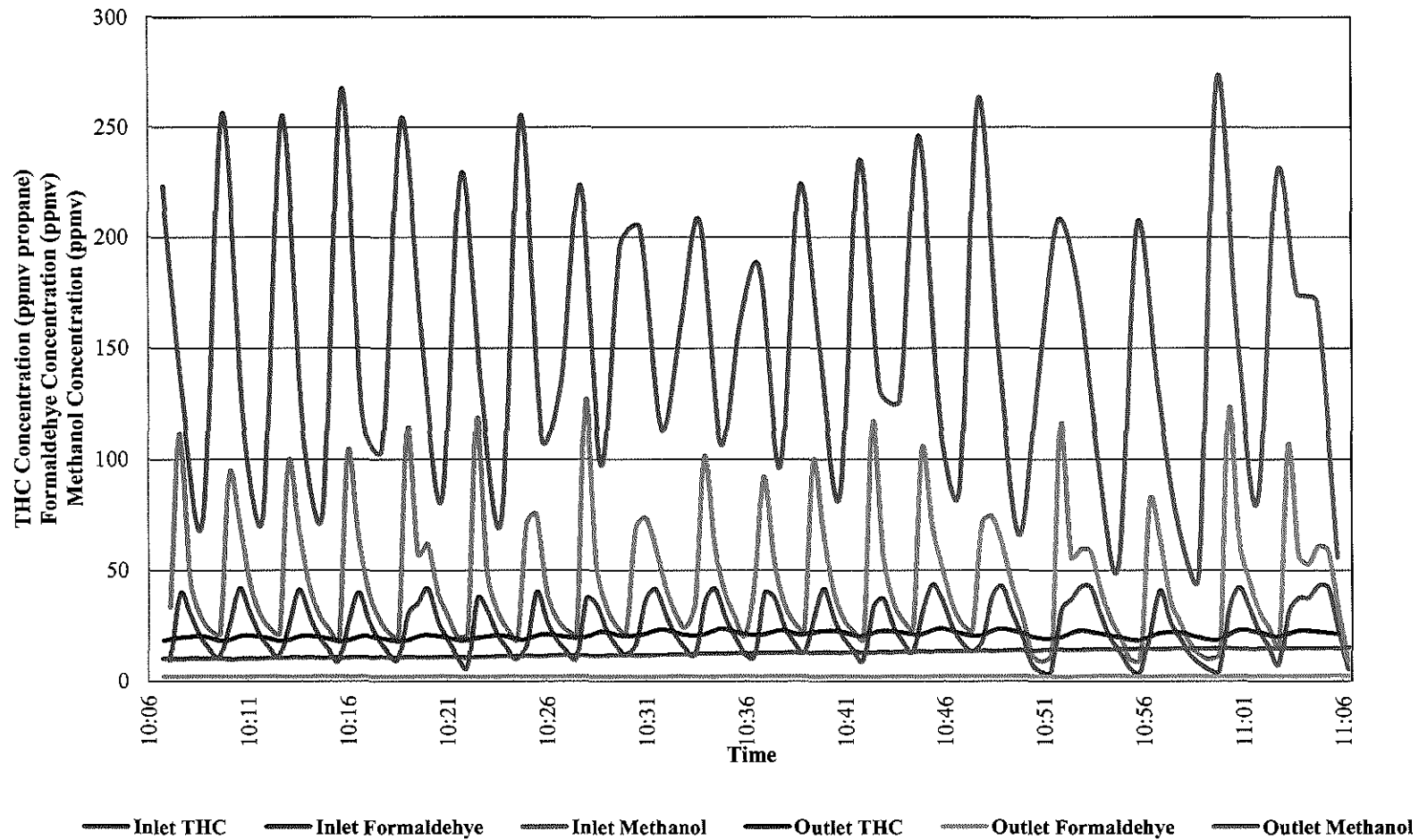



No. 1 Biofilter Inlet and Outlet Concentrations - Run 2
Decorative Panels International, Inc.
Alpena, Michigan
Bureau Veritas Project No. 11017-000100.02
Sampling Date: October 12, 2017

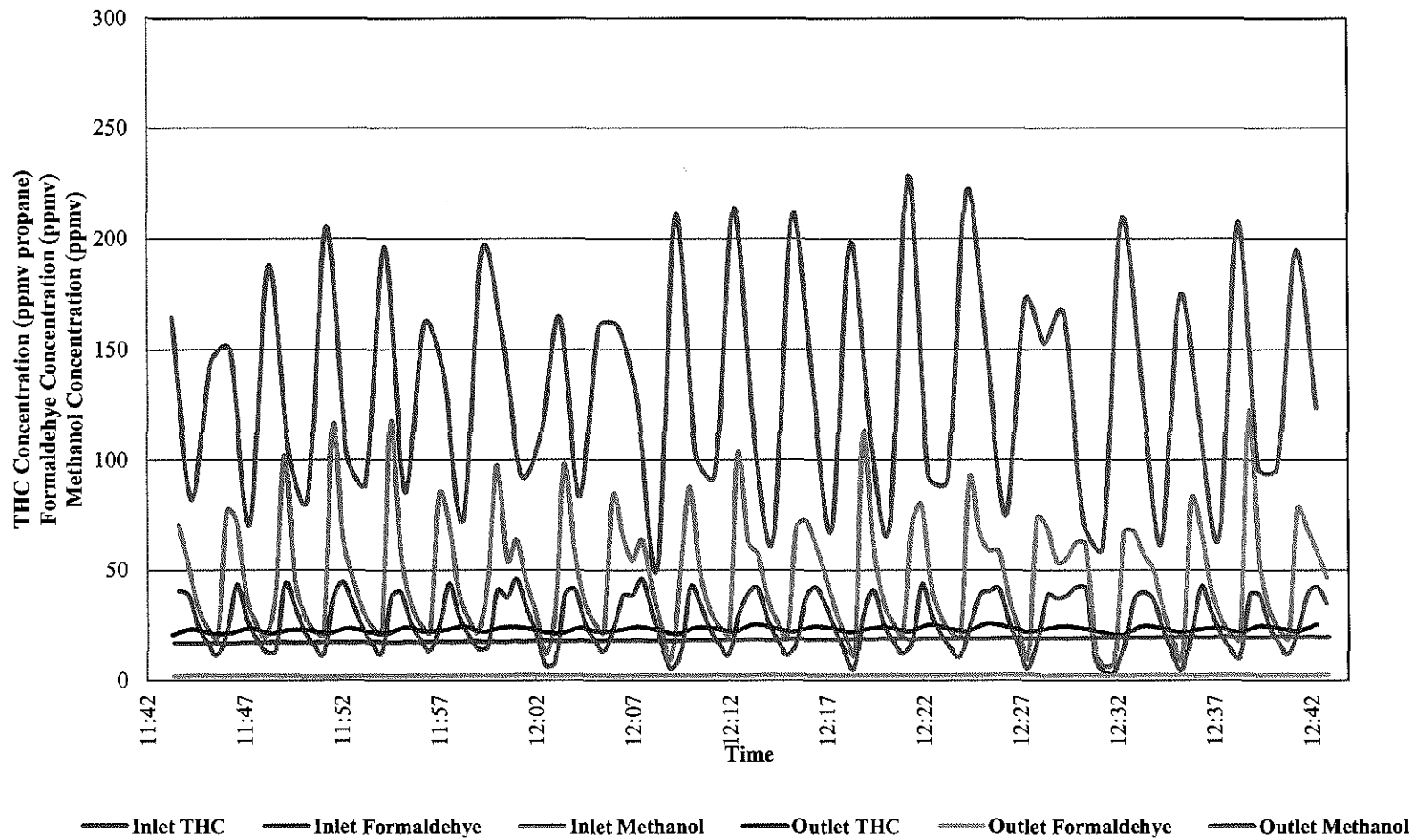



No. 1 Biofilter Inlet and Outlet Concentrations - Run 3
Decorative Panels International, Inc.
Alpena, Michigan
Bureau Veritas Project No. 11017-000100.02
Sampling Date: October 12, 2017

