

**STACK EMISSIONS STUDY
EPA 40 CFR PART 63 SUBPART LLL
FOR
KILNS 20 AND 21
PREPARED FOR
HOLCIM (US) INC. D/B/A LAFARGE, SRN B1477
AT THE
ALPENA PLANT
ALPENA, MICHIGAN
OCTOBER 23-24, 2019**



Prepared and Reviewed by:

A handwritten signature in black ink, appearing to read "Thomas K. Graham".

Thomas K. Graham, PE, QSTI
Director of AHU

A handwritten signature in black ink, appearing to read "Logan K. Tsotsoros".

Logan Tsotsoros
AHU Support Staff

A handwritten signature in black ink, appearing to read "M. Sharief".

I, _____
Mars A. Sharief, QSTI
Sr. Regional Manager-Chicago, IL
certify that this testing was conducted and
this report was created in conformance
with the requirements of ASTM D7036

(this page intentionally left blank)

Table of Contents

1.0	INTRODUCTION	1
1.1	TEST PURPOSE AND OBJECTIVES	1
1.2	SUMMARY OF TEST PROGRAM	1
1.2.1	Participating Organizations	1
1.2.2	Industry	1
1.2.3	Air Permit and Federal Requirements	1
1.2.4	Plant Location	1
1.2.5	Equipment Tested	1
1.2.6	Emission Points	1
1.2.7	Emission Parameters Measured	2
1.2.8	Dates of Emission Test	2
1.2.9	Federal Certifications	2
1.3	KEY PERSONNEL	2
2.0	SUMMARY OF TEST RESULTS	2
3.0	SOURCE OPERATION	3
3.1	PROCESS DESCRIPTION	3
3.2	SAMPLING LOCATION	4
4.0	SAMPLING AND ANALYTICAL PROCEDURES	4
4.1	TEST METHODS	4
4.2	INSTRUMENT CONFIGURATION AND OPERATIONS FOR GAS ANALYSIS	5

APPENDICES

Appendix A	Test Results and Calculations
Appendix B	Emission Data Records
Appendix C	Calibration Gas Certifications
Appendix D	Quality Assurance and Quality Control Data
Appendix E	Equipment Calibration Records

**Stack Emissions Study
Kilns 20 and 21
Holcim (US) Inc. d/b/a Lafarge, SRN B1477
Alpena Plant
Alpena, Michigan
October 23-24, 2019**

1.0 INTRODUCTION

Air Hygiene International, Inc. (Air Hygiene) has completed the Stack Emissions Study for particulate matter (PM) from the exhaust of Kilns 20 and 21 for Holcim (US) Inc. d/b/a Lafarge, SRN B1477 at the Alpena Plant in Alpena, Michigan. This report details the background, results, process description, and the sampling/analysis methodology of the stack sampling survey conducted on October 23-24, 2019.

1.1 TEST PURPOSE AND OBJECTIVES

The purpose of the test was to conduct a periodic compliance emission test to document levels of selected pollutants. The information will be used to confirm compliance with 40 Code of Federal Regulations (CFR) 60, Subpart LLL and the operating permit issued by the Michigan Department of Environmental Quality (MDEQ). The specific objective was to determine the emission concentration of PM from the exhaust of Holcim (US) Inc. d/b/a Lafarge, SRN B1477's Kilns 20 and 21.

1.2 SUMMARY OF TEST PROGRAM

The following list details pertinent information related to this specific project:

- 1.2.1 Participating Organizations
 - Michigan Department of Environmental Quality (MDEQ)
 - Holcim (US) Inc. d/b/a Lafarge, SRN B1477
 - Air Hygiene
- 1.2.2 Industry
 - Cement
- 1.2.3 Air Permit and Federal Requirements
 - Permit Number: MI-ROP-B1477-2012
 - 40 CFR 63, Subpart LLL
- 1.2.4 Plant Location
 - Alpena Plant in Alpena, Michigan
 - GPS Coordinates [Latitude 45.07095, Longitude -83.41489]
 - 1435 Ford Avenue, Alpena, Michigan 49707
 - Federal Registry System / Facility Registry Service (FRS) No. – 110015742605
 - Source Classification Codes (SCC) – 30501120, 30500699, and 30500613
- 1.2.5 Equipment Tested
 - Kilns 20 and 21
- 1.2.6 Emission Points
 - Exhaust from Kilns 20 and 21
 - For all molecular weight gases, a single sample point in the exhaust stack
 - For all wet chemistry testing, 27 or 25 sampling points in the exhaust stack from each unit

1.2.7 Emission Parameters Measured

- PM
- H₂O
- Flow
- CO₂
- O₂

1.2.8 Dates of Emission Test

- October 23-24, 2019

1.2.9 Federal Certifications

- Stack Testing Accreditation Council AETB Certificate No. 3796.02
- International Standard ISO/IEC 17025:2005 Certificate No. 3796.01



1.3 KEY PERSONNEL

Holcim (US) Inc. d/b/a Lafarge, SRN B1477:	Travis Weide (travis.weide@lafargeholcim.com)	989-358-3321
MDEQ:	Jeremy Howe	231-878-6687
MDEQ:	Kurt Childs	231-878-2045
Air Hygiene:	Mars Sharief (msharief@airhygiene.com)	918-307-8865
Air Hygiene:	James Reynolds	918-307-8865
Air Hygiene:	Atlas Melchert	918-307-8865
Air Hygiene:	Jeff Reese	918-307-8865

2.0 SUMMARY OF TEST RESULTS

Results from the sampling conducted on Holcim (US) Inc. d/b/a Lafarge, SRN B1477's Kilns 20 and 21 located at the Alpena Plant on October 23-24, 2019 are summarized in the following tables and relate only to the items tested.

The results of all measured pollutant emissions were above the required limits. All testing was performed without any real or apparent errors. All testing was conducted according to the approved testing protocol.

**TABLE 2.1
KILN 20 EMISSIONS DATA SUMMARY**

Historical Data	K20-PM-1	K20-PM-2	K20-PM-3	Average	Units	Limits
Run Start Time	09:52	11:54	13:28		hh:mm	
Run Stop Time	11:25	13:08	14:34		hh:mm	
Test Date	10/23/19	10/23/19	10/23/19		mm/dd/yy	
Production Rate	59.42	49.53	52.00	53.65	ton/hr	--
Emission Rate Data	K20-PM-1	K20-PM-2	K20-PM-3	Average	Units	Limits
Filterable PM Mass	20.09	23.35	15.48	19.64	mg	--
Filterable PM Emission Rate	5.74	6.56	4.29	5.53	lb/hr	--
	0.10	0.13	0.08	0.10	lb/ton	0.07

**TABLE 2.2
KILN 21 EMISSIONS DATA SUMMARY**

Historical Data	K21-PM-1	K21-PM-2	K21-PM-3	Average	Units	Limits
Run Start Time	06:54	08:25	09:52		hh:mm	
Run Stop Time	08:01	09:32	11:10		hh:mm	
Test Date	10/24/19	10/24/19	10/24/19		mm/dd/yy	
Production Rate	52.10	64.90	55.40	57.47	ton/hr	--
Emission Rate Data	K21-PM-1	K21-PM-2	K21-PM-3	Average	Units	Limits
Filterable PM Mass	18.42	22.32	14.98	18.57	mg	--
Filterable PM Emission Rate	5.90	6.99	4.78	5.89	lb/hr	--
	0.11	0.11	0.09	0.10	lb/ton	0.07

**TABLE 2.3
PM-CPMS SUMMARY RESULTS**

Unit	PM Emissions	PM Limit	PM-CPMS	Operating Limit
	lb/tons clinker	lb/ton clinker	mA	mA
K20 Stack	0.10	0.07	4.36	4.18
K21 Stack	0.10	0.07	5.47	4.75

Table 2.3 represents the PM-CPMS Operating limits. The sources must comply with PC MACT Regulation 40 CFR 63, Subpart LLL. The PM-CPMS Operating Limit was calculated using the equations:

$$O_i = z + ((0.75 * L) / R) \quad \text{and} \quad R = Y_1 / (X_1 - z)$$

Where,

O_i = Operating limit for PM CPMS on a 30 day rolling average (mA)

L = Source emission limit (lb/ton clinker)

z = Instrument zero (mA)

R = Relative lb/ton of clinker per mA

Y_1 = Three run average lb/ton of clinker PM concentration

X_1 = Three run average mA

3.0 SOURCE OPERATION

3.1 PROCESS DESCRIPTION

The Alpena Plant is located in Alpena, Michigan. The Raw Mill System mixes and grinds the raw materials (limestone, sand, bauxite, Bell shale, gypsum) and alternate raw materials (slag, iron ore, fly ash, and CKD) then sends the materials to the kilns.

Holcim (US) Inc. d/b/a Lafarge, SRN B1477 operates five rotary kilns, which manufacture Portland cement clinker using the dry process. A mixture of pulverized bituminous coal and petroleum coke, with a heating value

of approximately 11,750 Btu per pound, serves as the primary fuel fed to the kilns. Coal and coke are fed to a Raymond bowl mill and ground to a fineness of approximately 95% passing a 200-mesh sieve.

Kiln Group 5:

Kiln Group 5 at the Alpena Plant consists of three rotary kilns (#19, #20, and #21). Specific components of Kiln Group 5 are:

- Coal/petroleum coke and combustion air delivery;
- Raw mix preparation and delivery;
- Three rotary kilns;
- Kiln burners; and
- Air pollution control system, consisting of the following components:
 - Boiler;
 - Multiclone dust collectors;
 - Baghouses;
 - SNCR;
 - Induced draft (ID) fans; and
 - Exhaust stacks.

Allis Chalmers manufactured all kilns identified as #19, #20, and #21. Each kiln is 460.5 feet long. Each kiln shell has an inside diameter of 15 feet at the feed end and 13 feet at the firing end. The kilns in Kiln Group 5 rotate at speeds of greater than 40 revolutions per hour and are driven by an electric motor.

Dracco manufactured the baghouse for Kiln 19. The baghouse has two parallel sets of six chambers with a designed airflow of 175,000 cubic feet per minute (cfm) at 400°F. The maximum operating temperature is 550°F. The baghouses for kilns 20 and 21, manufactured by Wheelabrator-Frye are identical in design and construction, with two parallel sets of six chambers. Each baghouse has a designed air flow of 166,000 cfm at 400°F. The maximum operating temperature is 550°F.

3.2 SAMPLING LOCATION

The baghouse breeching ducts have been demonstrated as acceptable locations to conduct EPA reference method testing on all kilns. For each location the stack sampling occurs at the breeching duct between each kiln's baghouse and discharge stack. Ductwork geometry is adequate for collecting a representative sample of gaseous constituents at this point. Further descriptions of all sampling locations for this test program are provided in Appendix B.

4.0 SAMPLING AND ANALYTICAL PROCEDURES

4.1 TEST METHODS

The emission test on Kilns 20 and 21 at the Alpena Plant was performed following United States Environmental Protection Agency (EPA) methods described by the Code of Federal Regulations (CFR). Table 4.1 outlines the specific methods performed on October 23-24, 2019.

**TABLE 4.1
SUMMARY OF SAMPLING METHODS**

Pollutant or Parameter	Sampling Method	Analysis Method
Sample Point Location	EPA Method 1	Equal Area Method
Stack Flow Rate	EPA Method 2	S-Type Pitot Tube
Oxygen	EPA Method 3A	Paramagnetic Cell
Carbon Dioxide	EPA Method 3A	Nondispersive Infrared Analyzer
Stack Moisture Content	EPA Method 4	Gravimetric Analysis
Particulate Matter	EPA Method 5	Front Half Filterables

4.2 INSTRUMENT CONFIGURATION AND OPERATIONS FOR GAS ANALYSIS

The sampling and analysis procedures used during these tests conform with the methods outlined in the Code of Federal Regulations (CFR), Title 40, Part 60, Appendix A, Methods 1, 2, 3A, 4, and 5.

Figure 4.1 depicts the sample system used for the real-time gas analyzer tests. The gas sample was continuously pulled through the probe and transported, via heat-traced Teflon® tubing, to a stainless-steel minimum-contact condenser designed to dry the sample. Transportation of the sample, through Teflon® tubing, continued into the sample manifold within the mobile laboratory via a stainless steel/Teflon® diaphragm pump. From the manifold, the sample was partitioned to the real-time analyzers through rotameters that controlled the flow rate of the sample.

Figure 4.1 shows that the sample system was also equipped with a separate path through which a calibration gas could be delivered to the probe and back through the entire sampling system. This allowed for convenient performance of system bias checks as required by the testing methods.

All instruments were housed in a climate controlled, trailer-mounted mobile laboratory. Gaseous calibration standards were provided in aluminum cylinders with the concentrations certified by the vendor. EPA Protocol No. 1 was used to determine the cylinder concentrations where applicable (i.e. NOx calibration gases).

Table 4.2 provides a description of the analyzers used for the instrument portion of the tests. All data from the continuous monitoring instruments were recorded on a Logic Beach Portable Data Logging System which retrieves calibrated electronic data from each instrument every one second and reports an average of the collected data every 30 seconds.

Figure 4.2 represents the sample system used for the wet chemistry tests (PM). A heated stainless-steel probe with a glass liner and nozzle was inserted into the sample ports of the stack to extract gas measurements from the emission stream through a filter and glass impinger train. Flow rates are monitored with oil filled manometers and total sample volumes are measured with a dry gas meter.

The stack gas analysis for O₂ and CO₂ concentrations was performed in accordance with procedures set forth in EPA Method 3A. The O₂ analyzer uses a paramagnetic cell detector and the CO₂ analyzer uses a continuous nondispersive infrared analyzer.

TABLE 4.2
ANALYTICAL INSTRUMENTATION

Parameter	Manufacturer and Model	Range	Sensitivity	Detection Principle
CO ₂	SERVOMEX 1440	0-20%	0.1%	Nondispersive infrared
O ₂	SERVOMEX 1440	0-25%	0.1%	Paramagnetic cell, inherently linear.

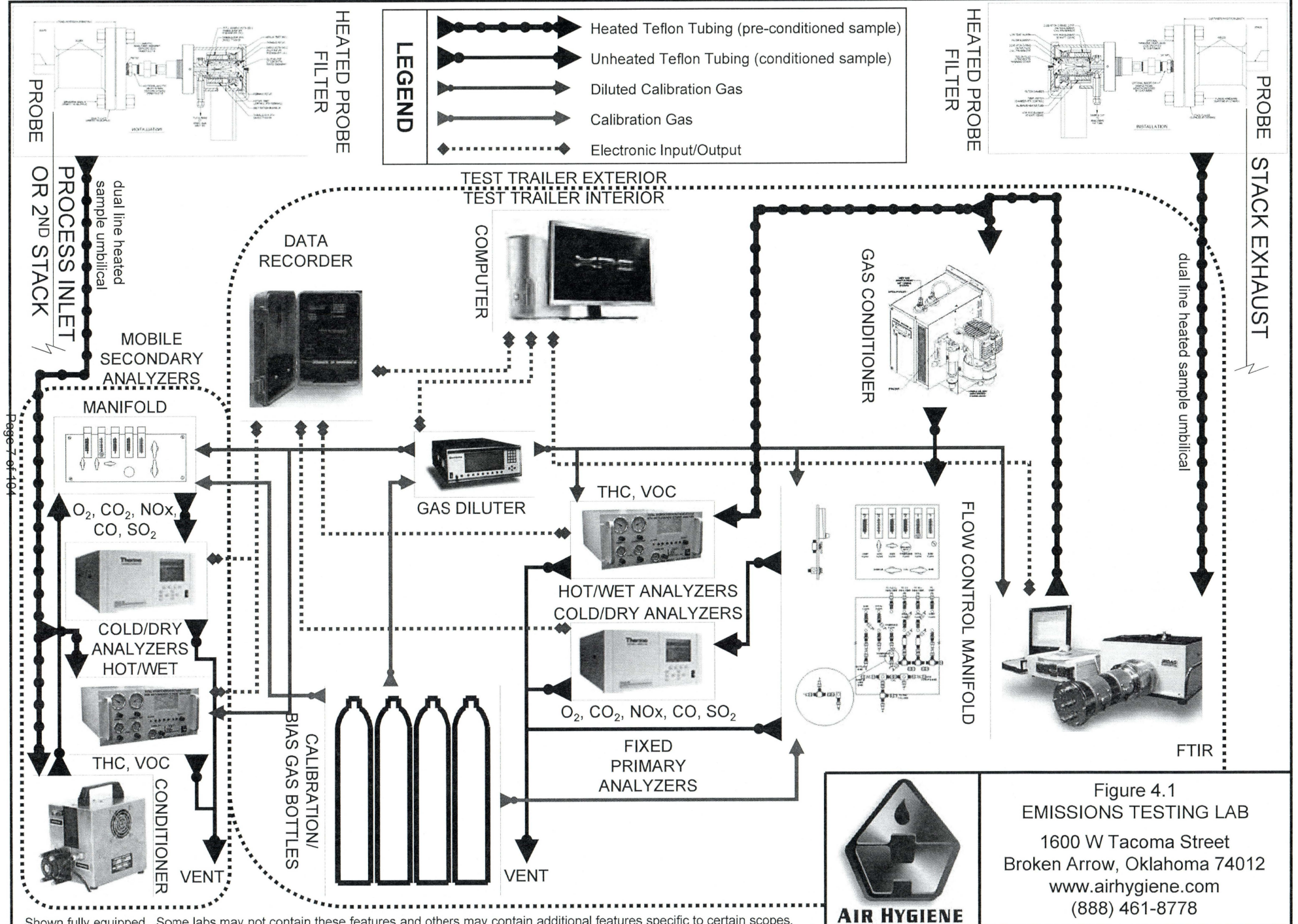

Page 7 of 104

Shown fully equipped. Some labs may not contain these features and others may contain additional features specific to certain scopes.



Figure 4.1
EMISSIONS TESTING LAB
 1600 W Tacoma Street
 Broken Arrow, Oklahoma 74012
 www.airhygiene.com
 (888) 461-8778

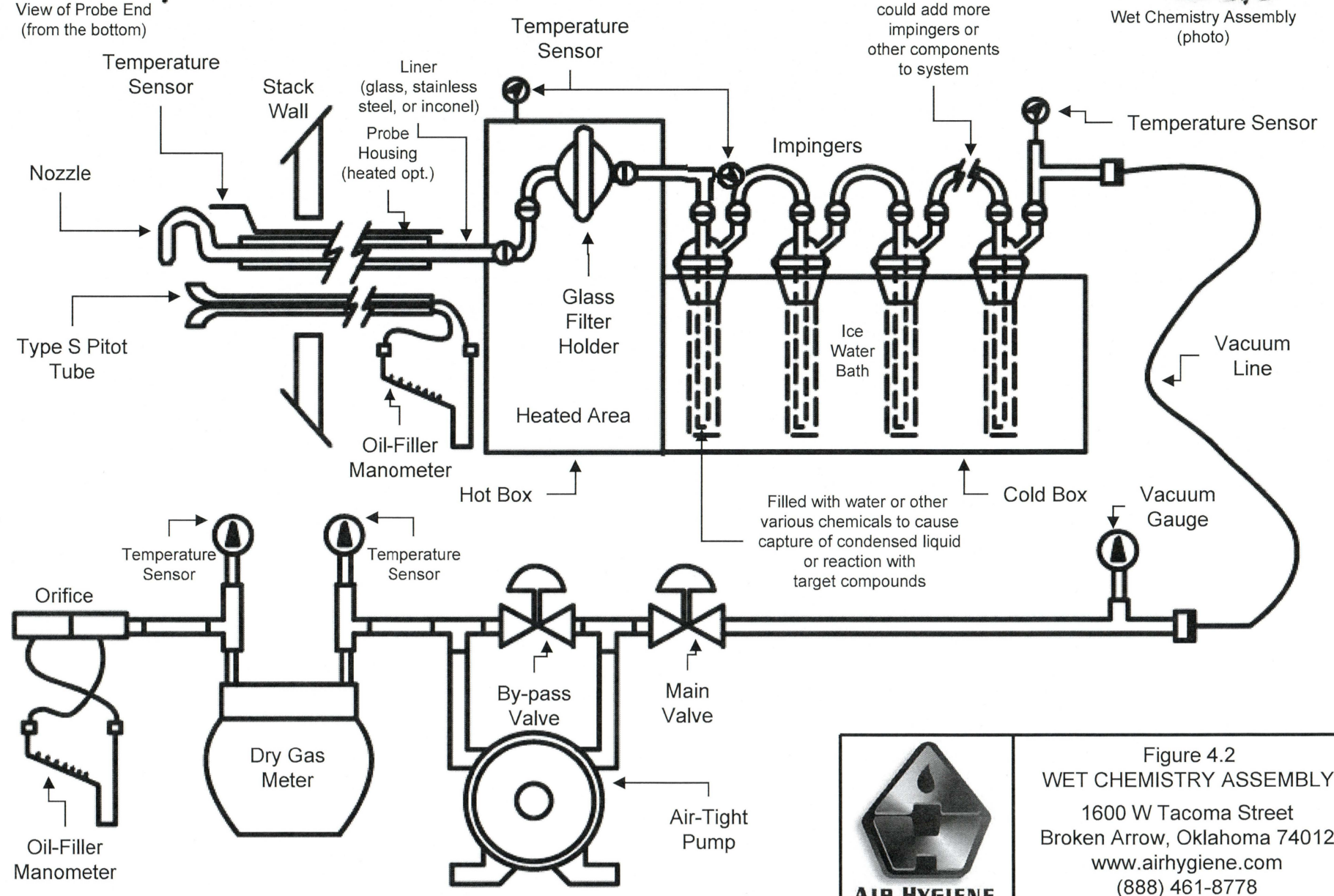
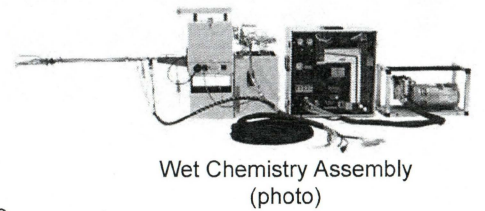
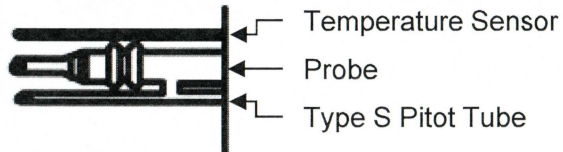

Page 8 of 104



Figure 4.2
WET CHEMISTRY ASSEMBLY
1600 W Tacoma Street
Broken Arrow, Oklahoma 74012
www.airhygiene.com
(888) 461-8778

APPENDIX A
TEST RESULTS AND CALCULATIONS