

**FPM & H₂SO₄ Test
Method Evaluation
on the
Trimer Control System**

**at
Guardian Industries, LLC
14600 Romine Rd
Carleton, MI 48117
(Line-2)**

Test Date: July 16-17, 2017

Project 18-339

Prepared by:
Empire Stack Testing, LLC. (AETB)
1090 Cain Road
Angola, New York 14006

Michael T. Karter

Michael T. Karter, QSTI (V)
General Manager
August 24, 2018

C:\Empire Stack Testing\PROJECT\2018\18-339 Guardian Carleton\Line-2 ACT\report\Line-2 ACT Report rev3.doc

RECEIVED

AUG 29 2018

AIR QUALITY DIVISION

1. TEST RESULTS SUMMARY (TRS)

Table 1-1: FPM Results Summary

Site	Date	Run	Stack Parameters				
			O ₂	CO ₂	Moisture	Temperature	Flow Rate
			(%)	(%)	(%)	(F)	(DSCFM)
RM 05 Outlet	7/16/2018	1 (1)	11.0	9.5	12.9	602	39689
	7/17/2018	2 (3)	11.0	7.8	12.4	597	41678
	7/17/2018	3 (5)	11.7	8.0	11.6	606	38791
	Average		11.2	8.4	12.3	602	40053
Site	Date	Run	FPM Emissions				
			(lbs/ton glass)	(lbs/hr)	(gr/DSCF)		
RM 05 Outlet	7/16/2018	1 (1)	0.03	0.62	0.002		
	7/17/2018	2 (3)	0.02	0.29	0.001		
	7/17/2018	3 (5)	0.28	5.32	0.016		
	Average		0.11	2.08	0.006		
Permit Limit			0.45	n/a	n/a		

Table 1-2: CTM 013 Results Summary

Site	Date	Run	Stack Parameters				
			O ₂	CO ₂	Moisture	Temperature	Flow Rate
			(%)	(%)	(%)	(F)	(DSCFM)
CTM 13 Outlet Ground Site	7/16/2018	1 (2)	11.0	9.5	15.0	601	39876
	7/17/2018	2 (4)	11.0	7.8	11.9	606	41630
	7/17/2018	3 (6)	11.7	8.0	13.9	609	39389
	Average		11.2	8.4	13.6	605	40298
Site	Date	Run	H ₂ SO ₄ Emissions				
			(lbs/ton glass)	(lbs/hr)	(ppmvd)		
CTM 13 Outlet Ground Site	7/16/2018	1 (2)	0.05	0.91	1.49		
	7/17/2018	2 (4)	0.04	0.73	1.15		
	7/17/2018	3 (6)	0.02	0.38	0.63		
	3 Run Average		0.04	0.67	1.1		
H ₂ SO ₄ Permit Limit			n/a	1.6	n/a		

RECEIVED

AUG 29 2018

AIR QUALITY DIVISION

Table 1-3: Production Data Summary

Production Data Summary					
Method	Date	Time	Production Rate		Pressure Drop
			Tons/Day	Tons/hr	in. WC
RM 05 Outlet	7/16/2018	1619-1730	449.2	18.72	10.7
	7/17/2018	0851-1014	450.6	18.78	10.1
	7/17/2018	1154-1327	450.6	18.78	10.5
CTM 13 Outlet Ground Site	7/16/2018	1619-1649	449.2	18.72	10.7
	7/17/2018	0852-0922	450.6	18.78	10.1
	7/17/2018	1155-1225	450.6	18.78	10.5

Table 1-4: Summary of Analytical QA/QC Results

Test Method	Parameter	QA/QC Criteria	Ground Site QA/QC Status	Outlet Site QA/QC Status	Within QC Criteria?
RM 2	Pitot Leak Check	Δ 0.0" H ₂ O / 15 seconds		0.0 @ 4.9" (max)	Yes
RM 5	Sample Train Leak Check (post test)	<0.02 cfm		0.017 cfm @ 20.0" H ₂ O (max)	Yes
RM5	Isokinetics	100% +/- 10%		97.9%-98.6%	Yes
CTM013	Sample Train Leak Check (post test)	<0.02 cfm	0.014 cfm @ 6.0" H ₂ O (max)		Yes
	Probe Temperature	> 350 °F	363°F (avg.)		Yes
	Thimble Temperature	> 500 °F	529°F (avg.)		Yes

3. INTRODUCTION

3.1 Introduction

Guardian Industries, LLC (Guardian) has contracted Empire Stack Testing, LLC. (Empire) to perform Filterable Particulate Matter (FPM) and Sulfuric Acid (H₂SO₄) testing services on their glass furnace in Carleton, Michigan. Testing will use RM5 at the Trimer outlet stack, and CTM-13 at the outlet ground site of the Trimer control system.

Section 3 of this protocol contains the sampling and analytical procedures used to perform the test program. Section 4 details the quality assurance/quality control (QA/QC) procedures for the test program.

3.2 Test Program Objective

This test program is required annually to quantify the FPM and H₂SO₄ emissions from the outlet of the Trimer control system. All testing will follow applicable methodologies of the Environmental Protection Agency (EPA), and as defined in Table 3-1, below.

3.3 Test Personnel

Coordinating the test program will be:

Michael Smolenski
Guardian Industries, LLC.
(734)-654-4283

Ancy Sebastian
ALS Environmental
(905)-331-3111

Michael T. Karter, QSTI
Empire Stack Testing, LLC.
(716)-481-6749

3.4 Test Plan

Testing for all parameters will be completed in triplicate following Reference Methods (RMs). The test program incorporates reference methods outlined in the United States Environmental Protection Agency (USEPA) Code of Federal Regulations Title 40, Part 60 (40CFR60), Appendix A. See Table 2-1 below.

3.5 Tentative Test Schedule

Day 1 (July 16): Mobilize to Guardian and finish setup for FPM & H₂SO₄ Testing
Day 2 (July 17): Complete FPM & H₂SO₄ Testing (~ 8 hours)
Day 3 (July 18): Demobilize from site

Table 3-1: Summary of Test Plan

PARAMETER	METHOD	ANALYSIS	SAMPLE DURATION (MINUTES)	TEST LOCATION(S)
Flow Rate	RM 1 & 2	S-Type Pitot Tube / Manometer	various	Outlet
Dry Molecular Weight	RM 3	O ₂ and CO ₂ Fyrites	various	Outlet & Outlet GS
Moisture	RM 4	Gravimetric	30	Outlet & Outlet GS
FPM	RM 5	Gravimetric	60	Outlet
H ₂ SO ₄ & SO ₂	CTM 013	Ion Chromatography	30	Outlet GS

NOTES:

- CTM: Conditional Test Method
- FPM: Filterable Particulate Matter
- GS: Ground Site
- H₂SO₄: Sulfuric Acid
- RM: United States Environmental Protection Agency Reference Method

3.6 Process Description

Flat glass manufacturing Line #2 consisting of a raw material melting Furnace, glass forming and finishing, and glass cutting. Line #2 produces flat glass using the float method. Materials are weighed and mixed with water in the batch house before entering the natural gas fired Furnace. Glass then enters the tin bath to be formed and drawn. Next, it enters a lehr to reduce its temperature. The emission unit is controlled by a new (Trimer ECS) Control Device consisting of a Dry Scrubber, Particulate Filter, and Selective Catalytic Reduction (SCR).

3.7 Plant data

The plant's SCADA system continuously records the operating data to be included in the test report. The plant shall provide plant operation and summarize pertinent operating data to represent plant operation. These data and summaries will be provided both electronically (MS Excel) and in paper copies.

3.8 Test Report

Empire will summarize the test program and subsequent results in a complete test report. An electronic DRAFT copy will be provided via email within 35 days of completed testing for review.

The report will include the test results in both tabular and text formats. The report will also include a summary of the methods and procedures followed during the program, and all applicable results from the QA lab. Copies of all field data sheets and onsite QA/QC results will be included. The data from at least a single test run will be hand

calculated to verify the spreadsheets and included in the report. The first page of the report will contain a Test Results Summary (TRS) that lists the following:

- Source and Source ID numbers
- Avg. Result(s) of each pollutant expressed in units of the Title V Operating Permit limits
- Title V permit limits for each pollutant tested
- Title V Permit Number
- Determination whether each pollutant's test results demonstrate compliance or noncompliance with the Title V Operating Permits for the tested Source.

3.8.1 Executive Summary

The report's Executive Summary will discuss in detail the test results and any anomalies, their resolution, and any effect on the results quality or usability. The Executive Summary will list all deviations from the approved pretest procedural protocol and problems associated with the sampling, recovery, analysis, or source/control device operation. For instance, dramatic or notable reduction or increase of emission results from test run to test run will be documented. In addition, laboratory notables and problems will be documented on the laboratory data section summary sheets.

The final test report will contain language in the executive summary section of the final report concerning any relevant discussions/agreements between the Department and any company and/or testing (includes other essential interested party) personnel of any notable issues that may generally and/or adversely affect testing, recovery, analysis, and process control operations. These types of correspondence may take place at the time of testing in the field or via telephone.

4. PRESENTATION OF RESULTS / EXECUTIVE SUMMARY

This Executive Summary discusses, in detail, the test results and any anomalies, their resolution, and any effect on the results quality or usability.

4.1 Discussion of Results

Testing was completed on July 16-17, 2018 for FPM, H₂SO₄, and SO₂. During this test program, the facility operated at a production rate of 449.2 and 450.6 tpd respectively.

The results indicate that the measured emissions are compliant with their permit limits. All field and lab data are included in the appendices of this report.

4.1.1 Isokinetics

Each RM 5 sample run for FPM met the isokinetic limit of 100 % ± 10%. These and other QAQC criteria are summarized in Table 1-4.

4.1.2 FPM Test Result (RM 5)

The average FPM emissions were measured to be 0.11 lbs/ton; which is compliant with limit of 0.45 lbs/ton. See Summary Table 1-1.

4.1.3 H₂SO₄ Test Result (CTM 013)

The 3-run average emission rate of sulfuric acid was 0.67 lbs/hr and 0.04 lbs/ton of glass. The unit demonstrated compliance with the emission limit of 1.6 lbs/hr. See Table 1-2.

4.2 Anomalies

No other anomalies were recorded during testing nor report production.

5. SAMPLING AND ANALYTICAL PROCEDURES

This section provides a brief overview of the specific test methods that will be used to determine the Sulfuric Acid emissions from each the glass furnace. All test method procedures will be performed in accordance with the USEPA Reference Methods given in 40CFR60, Appendix A. The details of each method are given in the following sections.

5.1 Reference Method Test Location

The emission point exhausts the gases from the furnace that produces float glass. Emissions are discharged to atmosphere after passing through the Trimer control system. The inlet test location is horizontal duct with an internal diameter (ID) of 6'-3". The vertical exhaust stack has an ID of 6'-6.5".

The inlet duct is fixed with a single 6-inch diameter port. The test ports are located approximately 5 equivalent diameters downstream of a disturbance and 1 equivalent diameters upstream of another disturbance. See Figure 3-1.

The exhaust stack is fixed with two 10-inch diameter ports. The test ports are located approximately 13 equivalent diameters downstream of a disturbance and 2.3 equivalent diameters upstream of another disturbance. See Figure 3-2.

The ground site of the exhaust stack is fixed with two 6-inch diameter ports. The test ports are located approximately 8 equivalent diameters downstream of a disturbance and 1 equivalent diameter upstream of another disturbance. See Figure 3-3.

5.2 Sampling Point Location

5.2.1 Volumetric Flow

Representative measurement of pollutant emissions and total volumetric flow rate from a stationary source requires a measurement site where the effluent stream is flowing in a known direction and cyclonic flow is not present. See section 3.3.1, below.

According to Reference Method 1, the cross section of the stack is divided into equal areas and a traverse point is then located within each of these areas. The number of duct diameters upstream and downstream from the test location to a flow disturbance determines the number of traverse points in a cross section.

As these stacks have diameters >24 inches the outermost traverse points will be at least 1 inch from the stack walls.

Sampling will be performed at 12 traverse points per traverse for a total of 24 sampling points, as set forth by RM 1. See Figures 3-3 and 3-4.

5.3 Stack Gas Velocity and Volumetric Flow Rate

According to Reference Method 2, the gas velocity in a stack will be determined from the average velocity head with a type S Pitot tube, gas density, stack temperature, and stack pressure.

The average velocity head will be determined by using an inclined manometer and a type S Pitot tube with a known coefficient of 0.84 that is determined geometrically by standards set forth in Reference Method 2. Stack temperature will be taken at each traverse point using a type K thermocouple. Static pressure will be determined by using a straight tap and an inclined manometer.

5.3.1 Cyclonic Flow Check

The cyclonic flow check was performed during previous testing in 2016 and demonstrated non-cyclonic, laminar flow. This data remains acceptable as the stack and duct configurations remain unchanged. These data will be included in the test report.

5.4 Oxygen & Carbon Dioxide Concentration (RM 3)

The Oxygen and Carbon Dioxide concentrations used in the calculation of the stack gases molecular weight will be measured according to RM-3 with grab samples and Fyrite gas analyzers.

5.5 Moisture Determination (RM 4)

The determination of effluent moisture will be performed as part of the wet-chemistry sampling, as detailed below in RM 5 and CTM013.

5.6 Filterable Particulate Matter (RM 5)

5.6.1 Background

Reference Method 5 will be used to determine the FPM concentrations. An integrated sample will be drawn from the stack. The filterable particulate will be quantified from the probe and filter catch.

5.6.2 Sampling

An isokinetic sample will be collected at a rate of approximately 0.7 cubic feet per minute (cfm) for 60 minutes. A heated glass probe, heated glass filter, and standard full-size impingers will be used. The first two impingers each contained 100 ml each of distilled water. The third impinger remained empty. The last impinger contained a known amount of silica gel. The second impinger is a Greenburg-Smith design; the remaining impingers are modified Greenburg-Smith designed. A schematic of the sampling train is presented in Figure 3-7. Both the probe and filter will be maintained at 250 °F, ±50 °F as required by the method.

5.6.3 Sample Recovery

Recovery of all sample train components will be performed in Empire's Mobile Laboratory.

Container 1:

The filter will be carefully removed from the filter holder with the use of tweezers and disposable surgical gloves, and placed into its Petri dish labeled with the filter ID number and identified as "Container No. 1" for the proper run and location. Any particulate matter and/or fiber filters that adhered to the filter holder or filter holder gasket will be carefully transferred to the Petri dish with the use of a dry nylon bristle brush or a sharp edged blade. The Petri dish will be then sealed with parafilm. The probe nozzle, probe liner, and front half of the filter holder will be rinsed at least three times with acetone, and the rinses collected in a sample jar labeled "Container No. 2". The container will be then sealed and the fluid level marked.

Container 2:

The particulate matter will be recovered from the probe nozzle, union, probe liner, front half of the filter holder, and (if applicable) the cyclone, as follows;

- a. The nozzle will be rinsed with acetone, brushed with a non-metallic bristle brush, and rinsed with acetone until no visible particles remained. A final acetone rinse will be performed.
- b. The probe liner will be rinsed and brushed at least three times, followed by a final rinse of the brush with acetone.

- c. After completing the rinses, the lid on the sample container will be tightened and the height of the fluid level marked.

Acetone Blank:

An acetone blank with a volume roughly equal to the rinse volume will be saved as a blank.

5.6.4 Analysis

The samples will be shipped to ALS Global (ALS) for analysis following RM 5. The filters are desiccated to a constant weight. The gravimetric analysis of the filters and acetone samples will be repeated every six to twenty-four hours until stable analyses are obtained.

ALS uses a 40 mL vial to analyze the acetone rinses, in lieu of evaporation in a 250 mL beaker. This minimizes the tare weight of the vessel; as the vials have a tare weight of approximately 21g compared to a tare weight of approximately 100g with a 250 mL glass beaker. The 250 mL glass beaker has a greater chance of variability; also the NJ-DEP (the primary NELAC accreditor) has certified ALS to perform this analysis with the modification listed.

The procedure used is as follows:

- The vials are kept in the balance room at all times prior to use. Lab numbers are put on the vials with a black magic marker and the vial is then desiccated for one hour prior to doing the pre-weight
- Place bottle of solvent onto Navigator balance, enter the weight into the "Bottle and Solvent Weight" column
- Place a ribbed watch glass on the sample container and set in a fume to evaporate to <10 mL
- Transfer the remaining solvent to a pre-cleaned, pre-weighed and pre-numbered 40 mL glass vial
- Place the empty bottle of solvent onto Navigator balance, enter weight into the "Empty Bottle Weight" column
- Reduce to dryness with a gentle stream of N₂ using the N-Evap system
- Place vials in desiccators for 24 hours minimum and record the time in the spreadsheet
- Note the appearance of the residue on the worksheet, (light, dark, minimal, copious as l/d/m/c)
- Proceed to 7.4 (Balance use and weighing samples)
- When all weightings are complete a second analyst must select and reweigh 1 of every 10 vials (the vial is to be selected at random)
Second analyst's result must be ± 2 mg of the first analyst's result.

5.7 Sulfuric Acid (CTM-013)

5.7.1 Background

This method was developed as an alternative to EPA Method 8 for determining sulfuric acid emissions from Kraft recovery furnaces. When testing recovery furnaces, EPA Method 8 is subject to significant interference from sulfates, which are present in the particulate matter, and sulfur dioxide. The alternative method uses a quartz in-line thimble to remove particulate matter from the gas stream prior to capturing sulfuric acid. The use of a controlled condensation technique eliminates the potential for interference from sulfur dioxide.

A gas sample is extracted from the sampling point in the recovery furnace stack. The sulfuric acid vapor or mist (including sulfur trioxide) and the sulfur dioxide are separated, and both fractions are measured separately by either the barium-thorin titration method or Ion Chromatography (IC).

5.7.2 Sampling

The sampling train consists of a glass nozzle and heated glass probe, which will be maintained at the temperature of >177°C (350°F). The probe will be then connected to the thimble holder housed in an oven box that will be also maintained at the temperature of >500 °F. The thimble holder will be constructed of quartz with a quartz thimble filter.

Sampling will be performed for a minimum of 30 minutes at a constant rate ($\pm 10\%$) of ~10.0 lpm (~0.35 cfm).

A condenser connects the thimble to the train. The condenser is filled with water and its temperature is maintained between 75 and 85°C (167 to 185°F). The condenser will be connected to the impinger train with a minimal length of unheated Teflon tubing. The first and third impingers consist of Greenburg-Smith design, the remaining impingers are modified Greenburg-Smith designed impingers. The first two impingers will contain 100 ml of 3% hydrogen peroxide (H₂O₂). The third impinger will contain 100 ml of distilled deionized water (RODI). The fourth impinger will contain approximately 500 g of silica gel desiccant.

A vacuum line connects the outlet of the last impinger to the control module. The control module consists of a vacuum gauge, rotary pump, by-pass and main valve, dry gas meter, orifice, and an inclined manometer. The sample train is illustrated in Figure 3-8.

Coinciding with the sampling will be velocity, moisture, and dry molecular weight determinations.

5.7.3 Sample Purge

At the completion of the test run, the probe will be separated from the thimble, and a 15-minute purge with clean air (ambient) will be performed at the same rate at the test run, as required by the method.

5.7.4 Sample Recovery

Recovery will be performed onsite in Empire's mobile laboratory at the completion of each test run.

Container 1:

Rinse separately the probe, quartz thimble holder and the H₂SO₄ condenser with deionized water using multiple rinse. After completing the rinses, the lid on the sample container will be tightened and the height of the fluid level marked. The thimble will be discarded.

Container 2:

The liquid from the first two impingers will be quantitatively transferred into a clean sample bottle (glass or plastic).

Container 3:

The water from the third impinger will be weighed in the field, and then discarded.

Blank H₂O₂:

Take ~100 ml of H₂O₂ and place it in a recovery bottle. The liquid level on the bottle will be marked.

Blank H₂O:

Take ~100 ml of H₂O and place it in a recovery bottle. The liquid level on the bottle will be marked.

5.7.5 Analysis

The samples will be shipped to ALS Environmental of Mississauga, Ontario, Canada for analysis for either IC or titration. The impinger solutions were also analyzed for SO₂.

Figure 5-1: Test Port Location (Outlet)

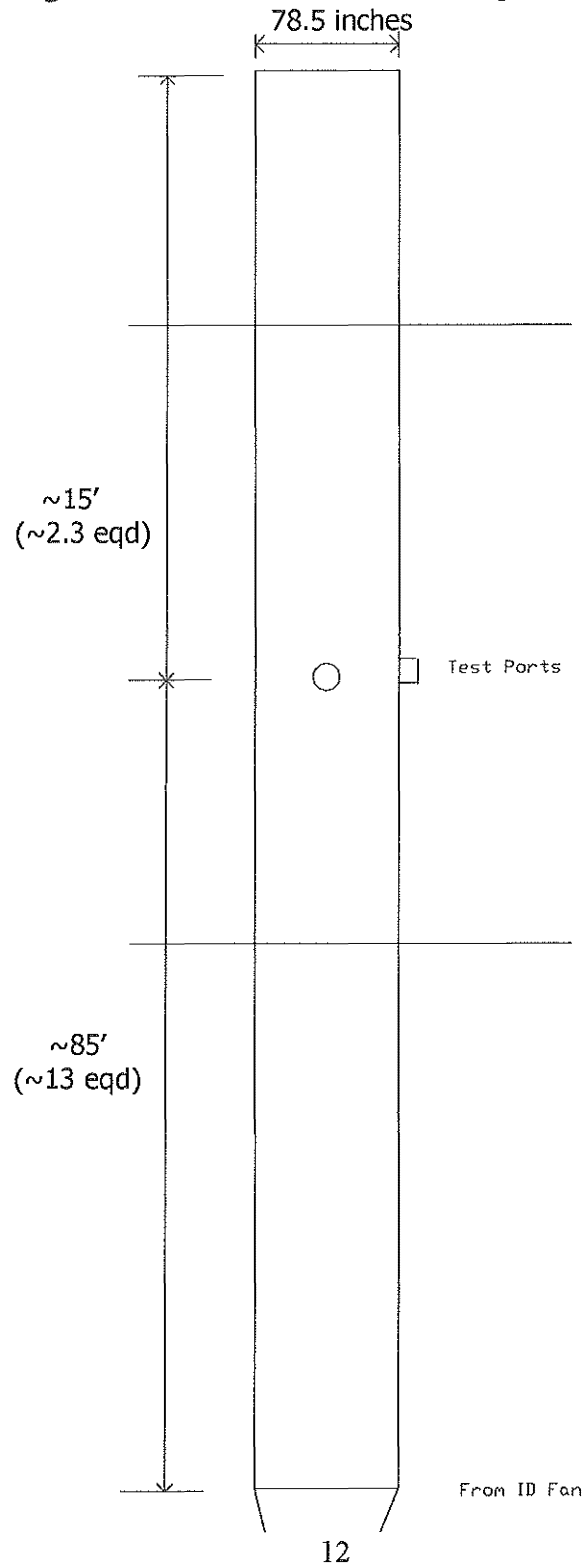

Figure 5-2: Test Port Location (Outlet Ground Site)

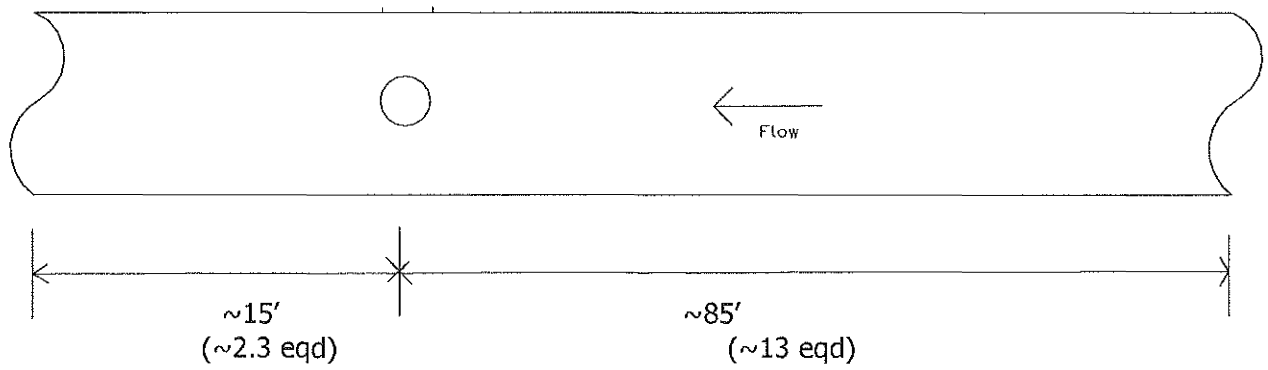
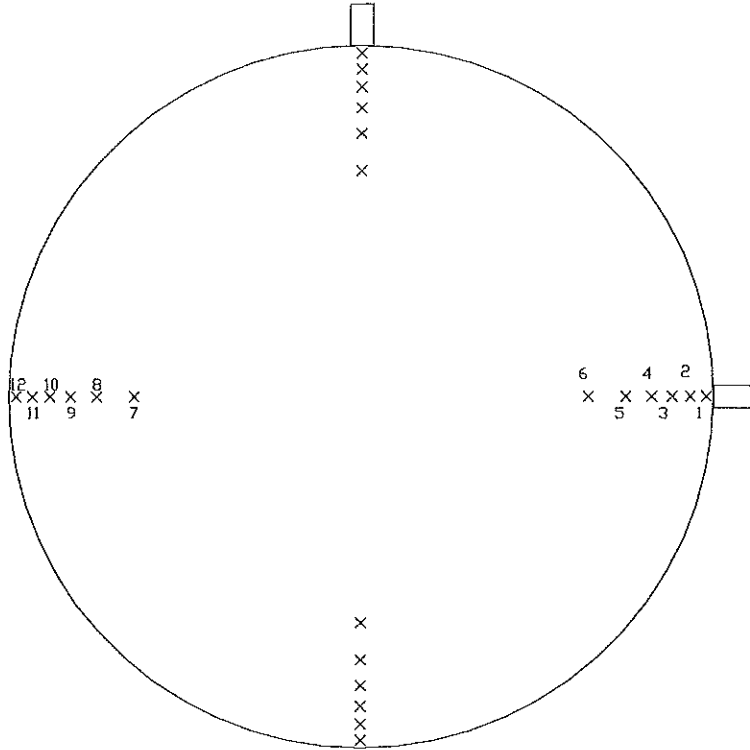
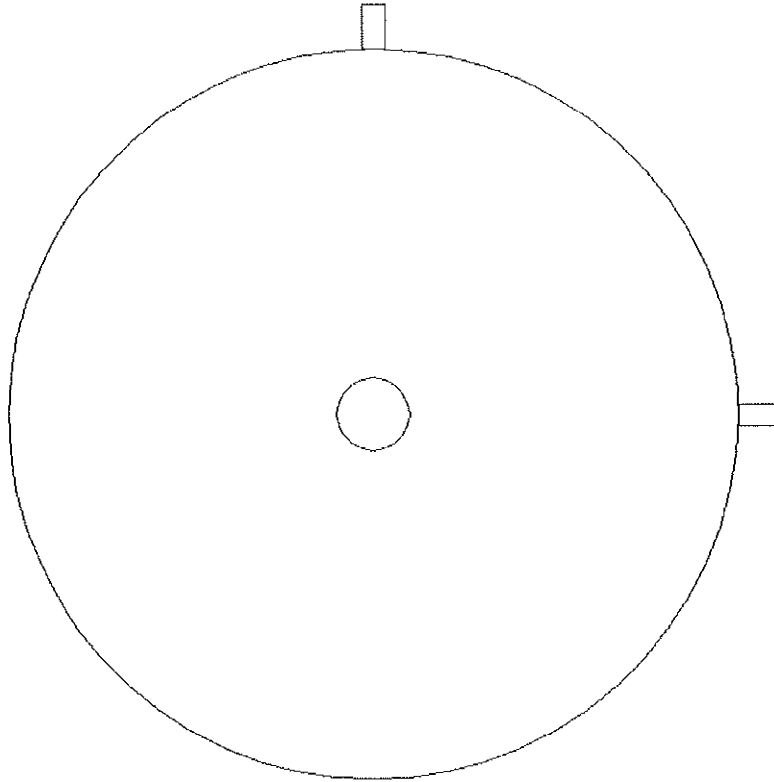

Figure 5-3: Sampling Point Locations (Outlet)



Traverse Point Number	Distance from Inner Wall (%)	Distance from Port Edge (inches)
1	2.1	11.6
2	6.7	15.3
3	11.8	19.3
4	17.7	23.9
5	25.0	29.6
6	35.6	37.9
7	64.4	60.6
8	75.0	68.9
9	82.3	74.6
10	88.2	79.2
11	93.3	83.2
12	97.9	86.9
Diameter:	78.5"	
Nipple:	10"	

Figure 5-4: Sampling Point Locations (Outlet Ground Site)



Note: Only a single port is present

<u>Traverse Point Number</u>	<u>Distance from Port Edge (inches)</u>
Centroid:	26.8 – 51.7"
Internal Dimensions:	78.5"
Port Length:	6"

Figure 5-5: RM 5 Sampling Train

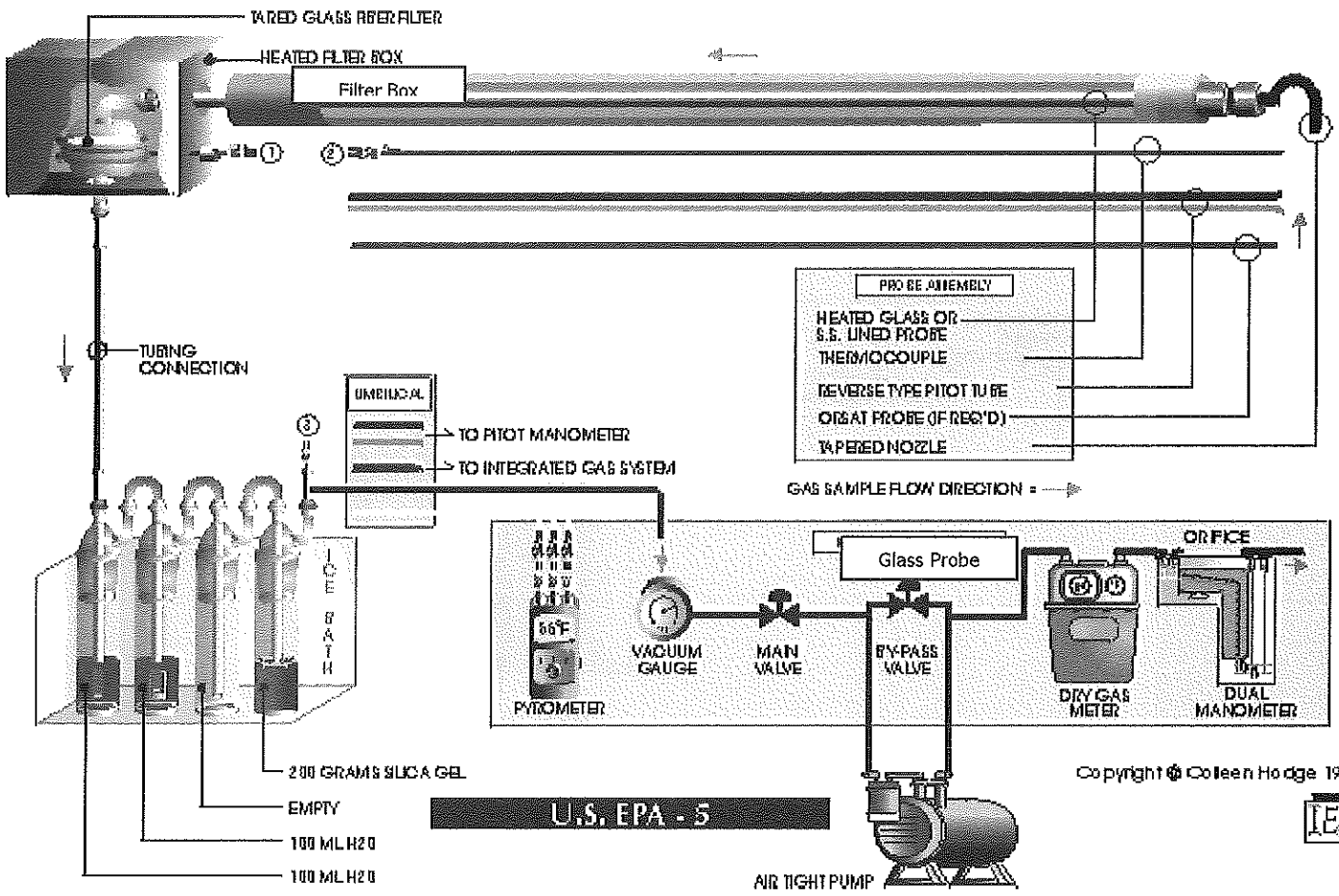

RECEIVED

AUG 29 2018

AIR QUALITY DIVISION

Figure 5-6: CTM 013 Sampling Train

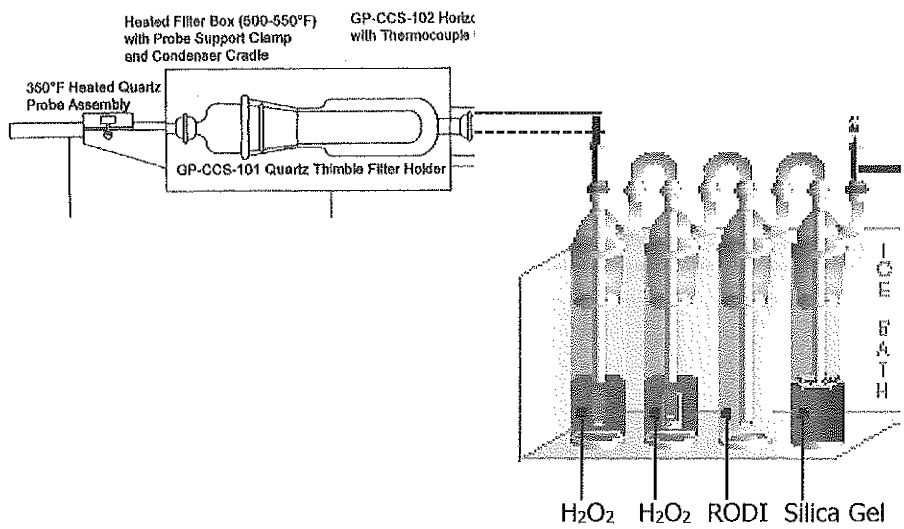

6. QUALITY ASSURANCE AND QUALITY CONTROL (QA/QC)

Quality control procedures for all aspects of field sampling, sample preservation and holding time, reagent quality, analytical methods, analyst training and safety, instrument cleaning, calibration, and safety will be followed. These procedures will be consistent with EPA Guidelines documented in:

- EPA 600/9-76-005, Quality assurance Handbook for Air Pollution Measurement Systems, Volume I
- EPA 454/R-98-004, Quality assurance Handbook for Air Pollution Measurement Systems, Volume II
- EPA 600/R-94-038c, Quality assurance Handbook for Air Pollution Measurement Systems, Volume III

6.1 Chain of Custody

Documentation of the Chain-of-Custody of samples and data obtained during the test program is essential for insuring the validity of the test program results. Chain-of-Custody procedures will be followed during sampling, sample and data transport, sample preparation and analysis, storage of data, as well as with archived samples and reported results. Empire follows the protocol listed in SW 846, Section 1.3 during field sampling and in-house laboratory analysis.

6.2 Equipment and Sampling Preparation

Sampling equipment will be cleaned, checked, and calibrated prior to use in the field. Each parameter's sampling method requires specific cleaning methods of the glassware, train components, and recovery containers. These materials will be then sealed prior to shipment to the field.

6.3 Calibrations

6.3.1 Pitot Calibration

Pitot tubes will be calibrated according to Reference Method 2, Section 10.1. Pitot tubes will be given a baseline coefficient of 0.84 when they meet certain geometrically measured angles and dimensions as set forth in the method.

6.3.2 Thermocouple Display Calibration

Following Method 2, Section 10.3, an NIST Traceable Electronic Thermocouple Calibrator/Simulator (ALTEK) for post-test calibrations is used. If the display being calibrated and the ALTEK will be within +/-1°F and/or +/-2% of the reference temperature, the calibration is acceptable, else the display is re-calibrated.

6.3.3 Thermocouple Calibration

According to EMTIC GD-28, a single point (at ambient temperature) check of the thermocouple will be made prior to and following each test program. If the thermocouple being calibrated and the certified thermometer will be within +/- 2.0 °F of each other, the calibration is acceptable. The thermocouple must also respond appropriately to a change in temperature. Thermocouples that fail either of these criteria will be repaired or discarded.

6.3.4 Barometer Calibration

Empire's barometer is compared prior to and following testing with the barometer from the National Weather Service (NWS) located at the Buffalo International Airport. If the barometer disagrees from the Airport's absolute station pressure reading by more than +/- 2.3 millimeters (mm) (0.1 inch) of Hg, the barometer is adjusted. Elevation corrections will be performed if the barometer and NWS elevations differ by more than 10 feet (elevation) of each other.

If necessary, readings taken in the field will be corrected based on the degree of error between the Empire barometer and the NWS.

Alternatively, during testing, the barometric station pressure can be obtained online from the nearest NOAA or FAA weather station.

6.4 Leak Checks

6.4.1 Sample Trains (CTM013)

A leak-check prior to the sample run is optional; however, a leak-check after the sampling run is mandatory. The leak check will be conducted in accordance with the procedures outlined in Reference Method 5, Section 8.5.9, except that it will be conducted at a vacuum equal to or greater than the maximum value reached during the sampling run. If the leakage rate is found to be no greater than 0.02 cfm, the results will be acceptable and no correction will be applied to the total volume of dry gas metered.

6.4.2 Sample Trains (FPM)

Both pre- and post-run leak checks will be conducted. A pre-test leak check will be performed to verify integrity of the vacuum system. A leak check is mandatory at the conclusion of each isokinetic sampling run. The leak check will be conducted in accordance with the procedures outlined in Reference Method 5, Section 8.5.9, except that it will be conducted at a vacuum equal to or greater than the maximum value reached during the sampling run. If the leakage rate is found to be no greater than 0.02 cfm, the results will be acceptable and no correction will be applied to the total volume of dry gas metered.

6.4.3 Pitot Leak Check

The pitot tubes used during the test program will be leak checked prior to the test series and following each traverse set, as prescribed in RM 2, Section 8.1. The leak check will be performed by pressurizing the positive side of the pitot to at least 3 inches of water. No loss of pressure for 15 seconds indicates a successful leak check. This procedure will be repeated with a vacuum applied to the negative side of the Pitot tube as well.

6.5 Sample Recovery

All sample volumes and reagent volumes will be measured and recorded on Empire's recovery data sheets and included in the report. All recovery procedures will be intended to meet the requirements of the methods.

6.6 Sample Recovery

All sample volumes and reagent volumes will be measured and recorded on Empire's recovery data sheets and included in the report. All recovery procedures will be intended to meet the requirements of the methods.

6.7 Data Reduction

The QA/QC procedures for data reduction include using computer programs to generate tables of results. Results for at least one test run will be double-checked and re-calculated by hand. These pages will be included in the report.

The wet-chemistry data will be logged directly to a separate laptop hard drive, where calculations will be performed using MS-Excel spreadsheets. These data will be archived nightly to flash media. Copies of these data will be available in the field electronically or in print form, upon request. Paper datasheets will only be used in an emergency.

6.8 Safety

These methods involve hazardous materials, operations, and equipment. Empire established appropriate safety and health practices and determined the applicability of regulatory limitations before performing this test program.

The test site shall meet the criteria of RM 1. Test ports (loosened and cleaned), safe access, and suitable power to be provided by the client. The above items need to be ready upon arrival of the test crew.

Delay or Lost Time (delays) of the field crew due to causes beyond the control of Empire Stack Testing, LLC. (Empire) may include (but will be not limited to weather, cyclonic flow conditions, process upsets or failure, or the facility's inability to maintain the desired test conditions). Inclement weather includes (but is not limited to) lightning, strong rains, blizzards, high winds (≥ 30 mph), high humidity, and/or working temperatures below 20 °F or above 90 °F. Empire's field leader retains the right of final refusal to stop testing for any unsafe condition.