

DTE Energy



COMPLIANCE TEST REPORT

for

RELATIVE RESPONSE AUDIT (RRA)

**PARTICULATE MATTER CONTINUOUS EMISSIONS MONITORING
SYSTEM (PM CEMS)**

UNIT 1 – Stack

**St. Clair Power Plant
East China, Michigan**

February 20, 2017

RECEIVED

MAR 24 2017

AIR QUALITY DIV.

**Prepared By
Environmental Management & Resources
Environmental Field Services Group
DTE Corporate Services, LLC
7940 Livernois H-136
Detroit, MI 48210**



EXECUTIVE SUMMARY

DTE Energy's Environmental Management and Resources (EMR) Field Services Group performed a Relative Response Audit (RRA) on the Particulate Matter Continuous Emissions Monitoring System (PM CEMS). The RRA was performed on the Unit 1 FGD exhaust stack located at the St. Clair Power Plant, in East China, Michigan. The testing is required by 40 CFR Part 63, Subpart UUUUU. Testing was performed in accordance with Procedure 2 of 40 CFR Part 60, Appendix F. The testing was conducted on February 20, 2017.

A summary of the emission test results are shown below. Criterion for acceptable RRA results are located in Procedure 2 Sec 10.4(6)(I-III):

Relative Response Audit
Unit 1 Stack
St. Clair Power Plant
February 20, 2017

	PM CEMS (mg/acm) ¹	RM PM (mg/acm) ¹	PM CEMS (correlation)	Correlation (-25% Emission Limit)	Correlation (+25% Emission Limit)
Run 1	6.4	1.73	5.5	1.66	9.26
Run 2	6.2	2.69	5.3	1.55	9.15
Run 3	6.2	1.42	5.3	1.55	9.15
PM CEMS < Greatest PM CEMS Response on correlation regression line				<i>≤77.5 mg/acm</i>	<i>Pass</i>
2 of 3 PM CEMS within PM CEMS output range of correlation regression line				<i>≥0.1 mg/acm</i>	<i>Pass</i>
2 of 3 PM CEMS and RM w/in 25% of numerical emission limit on correlation regression line					<i>Pass</i>

¹mg/acm @ stack conditions

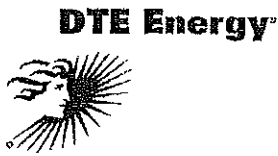

1.0 INTRODUCTION

DTE Energy's Environmental Management and Resources (EMR) Field Services Group performed a Relative Response Audit (RRA) on the Particulate Matter Continuous Emissions Monitoring System (PM CEMS). The RRA was performed on the Unit 1 FGD exhaust stack located at the St. Clair Power Plant, in East China, Michigan. The testing is required by 40 CFR Part 63, Subpart UUUUU. Testing was performed in accordance with Procedure 2 of 40 CFR Part 60, Appendix F. The testing was conducted on February 20, 2017.

Testing was performed pursuant to Title 40, *Code of Federal Regulations*, Part 60, Appendix A (40 CFR §60 App. A), Methods 1-5. Criterion for acceptable RRA results are located in Part 60, Appendix F Procedure 2 Sec 10.4(6)(i-iii).

The fieldwork was performed in accordance with EPA Reference Methods and EMR's Intent to Test.¹ The following EMR Field Services personnel participated in the testing program: Mr. Thomas Snyder, Environmental Specialist, Mr. Fred Meinecke, Senior Environmental Technician, and Ms. Tanecia Wilson, Environmental Technician. Mr. Grigereit was the project leader. Coordination with the facility was performed by Mr. Joe Neruda, Sr. Environmental Specialist. Mr. Mark Dziadosz with the Air Quality Division of the Michigan Department of Environmental Quality (MDEQ) reviewed the test plan and observed the testing.

2.0 SOURCE DESCRIPTION

The St Clair Power Plant (SCPP) located at 4901 Pointe Drive in East China Township, Michigan, employs the use of six (6) coal-fired boilers (Units 1-4, 6, and 7). Units 1-4 each have Babcock and Wilcox boilers capable of producing 1,070,000 pounds per hour of steam. Units 1 and 4 are equipped with General Electric turbine generators each with a nominally rated capability of 167 megawatts (MW). Units 2 and 3 have Allis Chalmers turbine generators each with a nominally rated capability of 170 MW. Units 6 and 7 have Combustion Engineering boilers capable of producing 2,100,000 and 3,580,000 pounds of steam per hour respectively. The turbine generators on each unit were manufactured by Westinghouse and have a nominally rated capability of 325 and 500 megawatts respectively.

¹ MDEQ, Test Plan, Submitted October 16, 2016. (Attached-Appendix A)

DTE Energy



St. Clair Power Plant utilizes Sick AG Maihak SP100 dust measuring systems. The analyzers utilize a measuring technique based off of scattered light principal. The SP100 model is specific for low to medium dust collections. The following unit was audited:

Unit	Analyzer	Manufacturer/ Model	Analyzer Range	Serial Number
Unit 1	PM	Sick/ Maihak SP100	200 mg/acm	15288501

3.0 SAMPLING AND ANALYTICAL PROCEDURES

DTE Energy obtained emissions measurements in accordance with procedures specified in the *USEPA Standards of Performance for New Stationary Sources*. The sampling and analytical methods used in the testing program are indicated in the table below

Sampling Method	Parameter	Analysis
USEPA Methods 1-2	Exhaust Gas Flow Rates	Field data analysis and reduction
USEPA Method 3A	O ₂ & CO ₂	Instrumental Analyzer Method
USEPA Method 4	Moisture Content	Field data analysis and reduction
USEPA Method 5 - MATS Modified	Particulate Matter	Gravimetric Analysis

3.1 **STACK GAS VELOCITY AND FLOWRATES (USEPA Methods 1-2)**

3.1.1 *Sampling Method*

Stack gas velocity traverses were conducted in accordance with the procedures outlined in USEPA Method 1, "Sample and Velocity Traverses for Stationary Sources," and Method 2, "Determination of Stack Gas Velocity and Volumetric Flowrate." Three (3) sampling ports were utilized on each unit's exhaust stack, sampling at three (3) points per port for a total of nine (9) points. One sampling port was unavailable due to placement of the units' elevator. Velocity traverses were conducted



simultaneously with the particulate sampling. See Figure 1 for a diagram of the traverse/sampling points used.

Cyclonic flow checks were performed on each stack during the initial flow monitor certification RATAs. Testing at the sampling location demonstrated that no cyclonic flow was present at either location. No changes to the stacks have occurred since the cyclonic flow checks were performed. Additionally, verifications of null angle at 0° were observed while performing static pressure checks on each unit.

3.1.2 Method 2 Sampling Equipment

The EPA Method 2 sampling equipment consisted of a 0-10" incline manometer, S-type Pitot tube ($C_p = 0.84$) and a Type-K calibrated thermocouple.

3.2 OXYGEN & CARBON DIOXIDE (USEPA Method 3A)

3.2.1 Sampling Method

Oxygen (O_2) and carbon dioxide (CO_2) emissions were evaluated using USEPA Method 3A, "Gas Analysis for Carbon Dioxide, Oxygen, Excess Air, and Dry Molecular Weight (Instrumental Analyzer Method)". The analyzers utilize paramagnetic sensors.

3.2.2 O_2/CO_2 Sampling Train

The EPA Method 3A sampling system (Figure 2) consisted of the following:

- (1) PTFE sampling line (collecting gas sample from the meter rig exhaust)
- (2) Universal[®] gas conditioner with particulate filter
- (3) PTFE connecting line
- (4) Servomax 1400 O_2/CO_2 gas analyzer
- (5) Appropriate USEPA Protocol 1 calibration gases
- (6) Data Acquisition System

3.2.3 Sampling Train Calibration

The O_2 and CO_2 analyzers were calibrated according to procedures outlined in USEPA Methods 3A. Zero, span, and mid range calibration gases were introduced directly into the analyzer to verify the instruments linearity, prior to sampling, and again at the completion of each test run.



3.3 MOISTURE DETERMINATION (USEPA Method 4)

3.3.1 *Sampling Method*

Determination of the moisture content of the exhaust gas was performed using USEPA Method 4, "Determination of Moisture Content in Stack Gases". The moisture was collected in the Method 5 glass impingers, and the percentage of water was then derived from calculations outlined in USEPA Method 4.

3.4 PARTICULATE MATTER (USEPA Method 5 - MATS Modified)

3.4.1 *Filterable Particulate Sampling Method*

USEPA Method 5 - MATS Modified, "Determination of Particulate Emissions from Stationary Sources" was used to measure the filterable (front-half) particulate emissions (see Figure 3 for a schematic of the sampling train). Triplicate, 67.5-minute test runs were conducted.

The Method 5 - MATS Modified modular isokinetic stack sampling system consisted of the following:

- (1) PTFE coated stainless-steel button-hook nozzle
- (2) Heated glass-lined probe
- (3) Heated 3" glass filter holder with a quartz filter
(Maintained at a temperature of 320 ± 25 °F)
- (4) Set of impingers for the collection of condensate for moisture determination
- (5) Length of sample line
- (6) Environmental Supply^o control case equipped with a pump, dry gas meter, and calibrated orifice.

The quartz filters used in the sampling were initially baked for 3 hours at 320 °F, desiccated for 24 hours and weighed to a constant weight as described in Method 5 - MATS Modified to obtain the initial tare weight.

After completion of the final leak test for each test run, the filter was recovered, and the probe, nozzle and the front half of the filter holder assembly were brushed and rinsed with acetone. The acetone rinses were collected in a pre-cleaned sample container. The container was labeled with the test number, test location, test date, and the level of liquid marked on the outside of the container. Immediately after recovery, the sample containers were placed in a cooler for storage.



At the laboratory the acetone rinses were transferred to clean pre-weighed beakers, and evaporated to dryness at ambient temperature and pressure. The beakers and filters were desiccated for 24 hours and weighed to a constant weight (within 0.5 mg). The data sheets containing the initial and final weights on the filters and beakers can be found in Appendix C.

Collected field blanks consisted of a blank filter and acetone solution blank. The acetone blank was collected from the rinse bottle used in sample recovery. The blank filter and acetone were collected and analyzed following the same procedures used to recover and analyze the field samples. Field data sheets for the Method 5 - MATS Modified sampling can be found in Appendix B.

3.4.2 Quality Control and Assurance

All sampling and analytical equipment was calibrated according to the guidelines referenced in EPA Method 5 - MATS Modified. All Method 1-5 calibration data is located in Appendix D.

3.4.3 Data Reduction

The filterable PM emissions data collected during the testing were calculated and reported as mg/acm @ stack conditions.

4.0 OPERATING PARAMETERS

The test program included the collection of PM CEMs emission data and Load during each PM emissions test. Data collected during the testing is presented in Appendix E.

5.0 DISCUSSION OF RESULTS

Table 1 presents the Unit 1 Reference Method particulate emission testing results (RM PM), particulate matter continuous emissions monitoring system (PM CEMS) results, PM CEMS correlation (expected point on the correlation regression line) value, and $\pm 25\%$ of the emission limit along the correlation regression line). Particulate emissions are presented in milligram per actual cubic meter calculated at stack conditions (mg/acm).

In order to pass an RRA, All of the following criteria must be met: Procedure 2 10.4(6)(i-iii).

- i) For all three data points, the PM CEMS response value can be no greater than the greatest PM CEMS response value used to develop your correlation curve.



- ii) For two of the three data points, the PM CEMS response value must lie within the PM CEMS output range used to develop your correlation curve.
- iii) At least two of the three sets of PM CEMS and Reference Method measurements must fall within the same specified area on a graph of the correlation regression line as required for the RCA and described in paragraph (5)(iii). "The specific area on the graph of the correlation regression line is defined by two lines parallel to the correlation regression line, offset at a distance of $\pm 25\%$ of the numerical emission limit value from the correlation regression line.

All three requirements were successfully met. Testing results are located in Table 1 "Unit 1 PM CEMS RRA Results" and Table 2 "Unit 1 PM CEMS RRA – Summary Graph)."

The auxiliary test data presented in the results table for each test includes the unit load in gross megawatts (GMW), stack temperature in degrees Fahrenheit ($^{\circ}\text{F}$), stack gas moisture in percent (%), stack gas velocity in feet per minute (ft/min), and stack gas flow rate in actual cubic feet per minute (acfm), standard cubic feet per minute (scfm) and dry standard cubic feet per minute (dscfm).



6.0 CERTIFICATION STATEMENT

"I certify that I believe the information provided in this document is true, accurate, and complete. Results of testing are based on the good faith application of sound professional judgment, using techniques, factors, or standards approved by the Local, State, or Federal Governing body, or generally accepted in the trade."

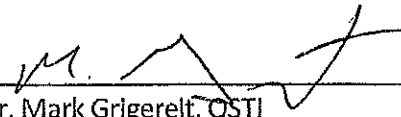

Mark Grigerelt, QSTI

This report prepared by: 

Mr. Mark Grigerelt, QSTI
Principal Engineer, Field Services Group
Environmental Management and Resources
DTE Energy

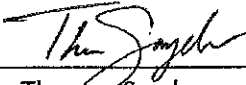
This report reviewed by: 

Mr. Thomas Snyder
Environmental Specialist, Field Services Group
Environmental Management and Resources
DTE Energy

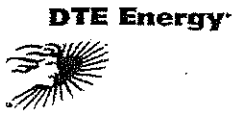

TABLE NO. 1
PARTICULATE MATTER CONTINUOUS EMISSIONS MONITORING SYSTEM
RELATIVE RESPONSE AUDIT RESULTS
St Clair Power Plant - Unit 1 FGD Stack
February 20, 2017

Test	Test Time	Unit Load (GMW)	Stack Temperature (°F)	Stack Moisture (%)	Stack Velocity (ft/min)	Exhaust Gas Flowrates			PM CEMS (mg/acm ³)	RM-PM (mg/acm ³)	PM CEMS (correlation)	Correlation (-25% Emission limit ²)	Correlation (+25% Emission limit ²)
						(ACFM)	(SCFM)	(DSCFM)					
RRA-1	7:44-8:56	99.0	255.7	6.4	4,005	559,190	415,812	389,215	6.4	1.73	5.5	1.66	9.26
RRA-2	9:14-10:25	97.3	259.2	7.2	4,036	563,501	416,945	386,762	6.2	2.69	5.3	1.55	9.15
RRA-3	10:47-11:58	97.4	261.0	6.0	4,134	577,277	426,086	400,487	6.2	1.42	5.3	1.55	9.15

(1) concentration @ stack conditions

(2) ±25% emission limit (3.8 mg/acm)



Figure 1 – Sampling Location & Traverse Points
St Clair Power Plant – Unit 1
February 20, 2017

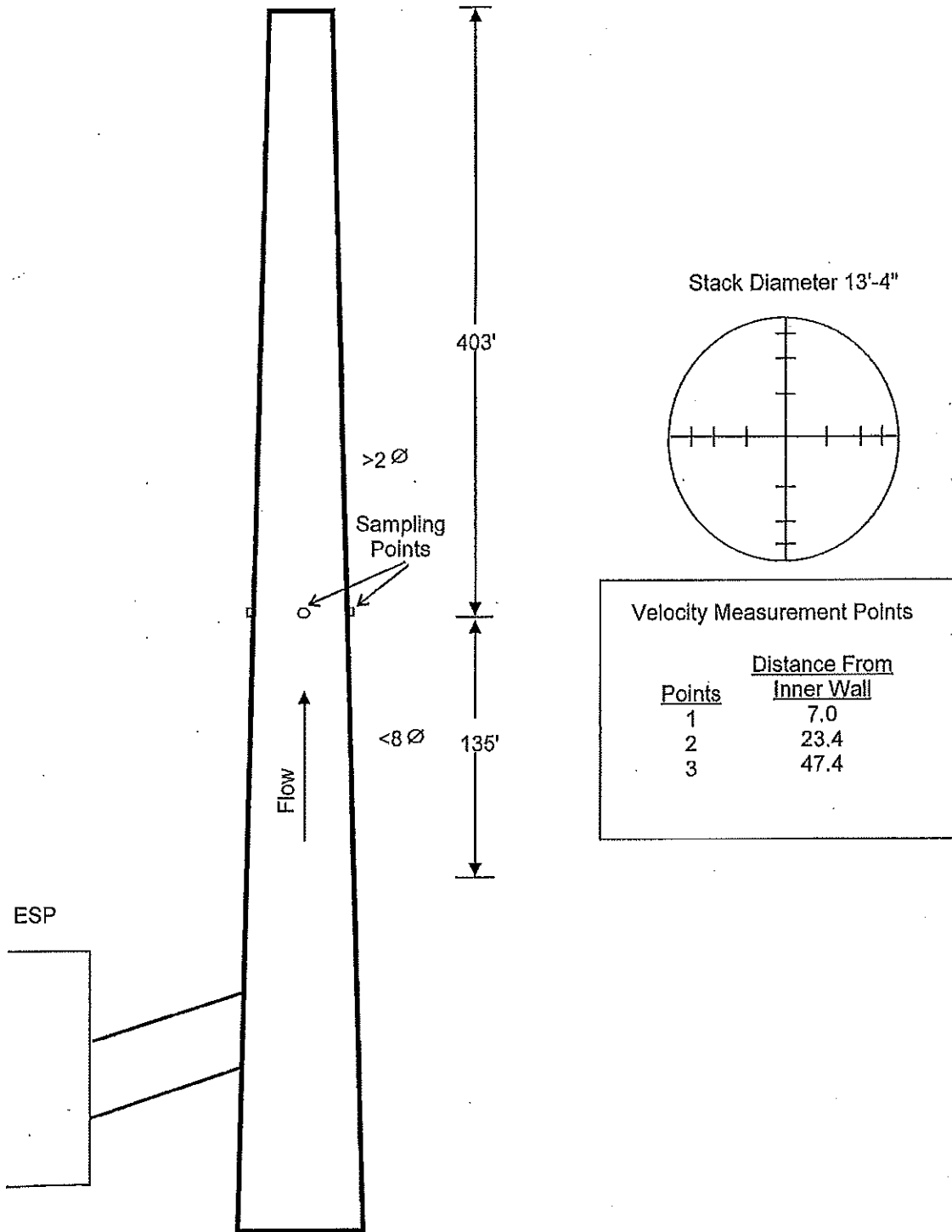



Figure 2 – EPA Method 3A
St Clair Power Plant – Unit 1
February 20, 2017

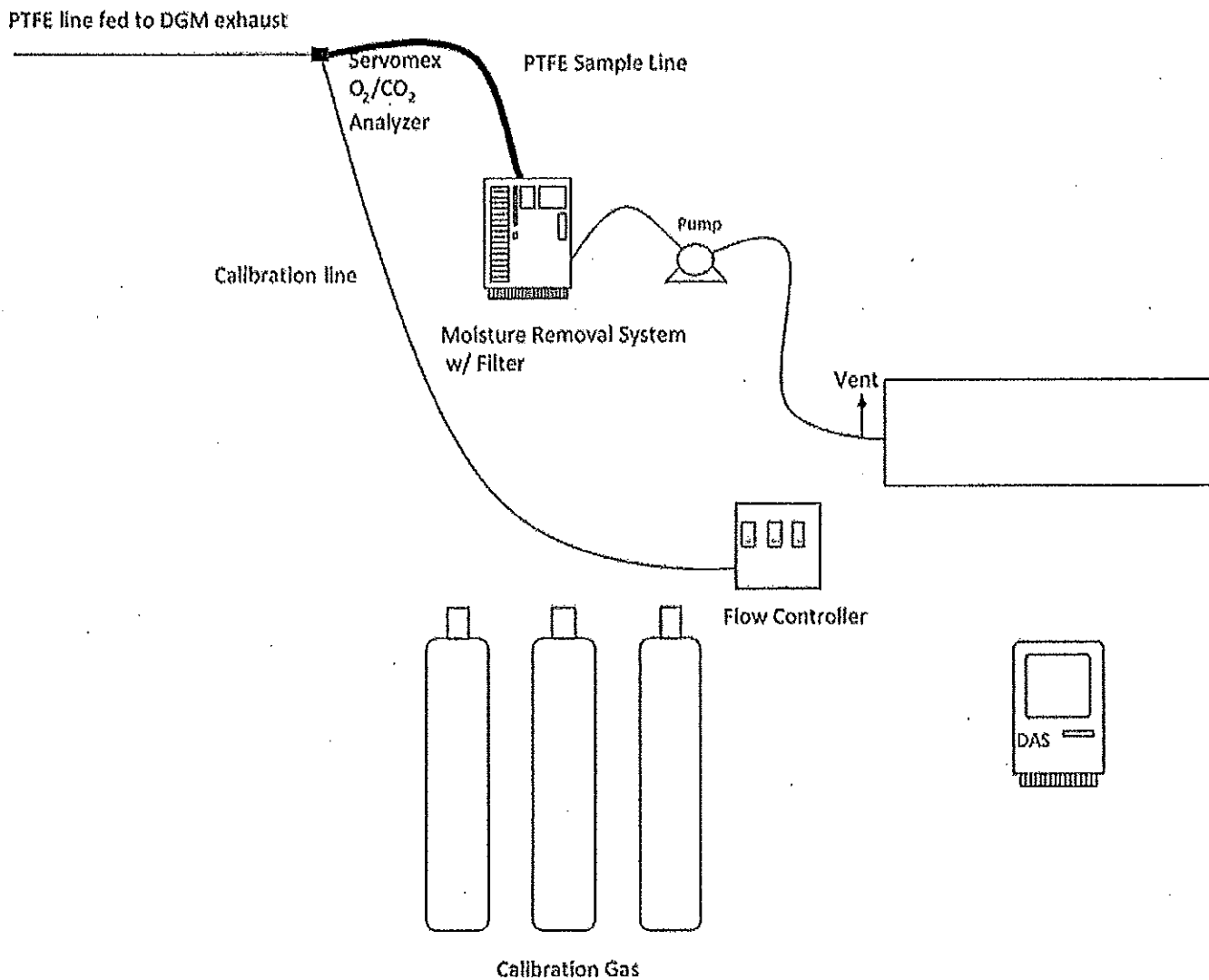



Figure 3 – EPA Method 5 – MATS Modified
St Clair Power Plant - Unit 1
February 20, 2017

