

## 1.0 INTRODUCTION

### 1.1 SUMMARY OF TEST PROGRAM

DTE Energy - Belle River Power Plant (BRPP) (Facility ID: B2796) contracted Montrose Air Quality Services, LLC (Montrose) to perform a compliance test program on the EU-BOILER1-BR at the DTE Energy - BRPP facility located in China, Michigan. Testing was performed on June 15, 2021, for the purpose of satisfying the emission testing requirements pursuant to Michigan Department of Environment, Great Lakes, and Energy (EGLE) Renewable Operation Permit (ROP) No. MI-ROP-B2796-2015c.

The specific objectives were to:

- Verify the filterable particulate matter (FPM) emissions from the Exhaust Stack serving EU-BOILER1-BR
- Conduct the test program with a focus on safety

Montrose performed the tests to measure the emission parameters listed in Table 1-1.

**TABLE 1-1  
SUMMARY OF TEST PROGRAM**

Test Date	Unit ID/ Source Name	Activity/ Parameters	Test Methods	No. of Runs	Duration (Minutes)
6/15/2021	EU-BOILER1-BR	Velocity/Volumetric Flow Rate	EPA 1 & 2	3	60
6/15/2021	EU-BOILER1-BR	O <sub>2</sub> , CO <sub>2</sub>	EPA 3A	3	5-9
6/15/2021	EU-BOILER1-BR	Moisture	EPA 4	3	60
6/15/2021	EU-BOILER1-BR	FPM	EPA 5	3	60

To simplify this report, a list of Units and Abbreviations is included in Appendix D.1. Throughout this report, chemical nomenclature, acronyms, and reporting units are not defined. Please refer to the list for specific details.

This report presents the test results and supporting data, descriptions of the testing procedures, descriptions of the facility and sampling locations, and a summary of the quality assurance procedures used by Montrose. The average emission test results are summarized and compared to their respective permit limits in Table 1-2. Detailed results for individual test runs can be found in Section 4.0. All supporting data can be found in the appendices.

The testing was conducted by the Montrose personnel listed in Table 1-3. The tests were conducted according to the Test Plan dated April 26, 2021, that was submitted to EGLE.



**TABLE 1-3  
TEST PERSONNEL AND OBSERVERS**

<b>Name</b>	<b>Affiliation</b>	<b>Role/Responsibility</b>
David Trahan	Montrose	Field Project Manager, QI
David Koponen	Montrose	Field Technician
Jason Roggenbuck	DTE Energy - BRPP	Observer/Client Liaison/Test Coordinator

## 2.0 PLANT AND SAMPLING LOCATION DESCRIPTIONS

### 2.1 PROCESS DESCRIPTION, OPERATION, AND CONTROL EQUIPMENT

DTE Energy owns and operates the Belle River Power Plant in China, Michigan. Energy is produced by a coal fired boiler (EU-BOILER1-BR) which was in operation during this testing event.

### 2.2 FLUE GAS SAMPLING LOCATION

Information regarding the sampling location is presented in Table 2-1.

**TABLE 2-1  
 SAMPLING LOCATION**

Sampling Location	Stack Inside Diameter (in.)	Distance from Nearest Disturbance		Number of Traverse Points
		Downstream EPA "B" (in./dia.)	Upstream EPA "A" (in./dia.)	
EU-BOILER1-BR Exhaust Stack	306	4800 / 15.7	1800 / 5.9	Isokinetic; 12 (3/port)

The sampling location was verified in the field to conform to EPA Method 1. Acceptable cyclonic flow conditions were confirmed prior to testing using EPA Method 1, Section 11.4. See Appendix A.1 for more information.

### 2.3 OPERATING CONDITIONS AND PROCESS DATA

Emission tests were performed while the source/units and air pollution control devices were operating at the conditions required by the permit. The unit was tested when operating normally.

Plant personnel were responsible for establishing the test conditions and collecting all applicable unit-operating data. The process data that was provided is presented in Appendix B. Data collected includes the following parameters:

- Facility CEMS data associated with the 60-minute runs

### **3.0 SAMPLING AND ANALYTICAL PROCEDURES**

#### **3.1 TEST METHODS**

The test methods for this test program were presented previously in Table 1-1. Additional information regarding specific applications or modifications to standard procedures is presented below.

##### **3.1.1 EPA Method 1, Sample and Velocity Traverses for Stationary Sources**

EPA Method 1 is used to assure that representative measurements of volumetric flow rate are obtained by dividing the cross-section of the stack or duct into equal areas, and then locating a traverse point within each of the equal areas. Acceptable sample locations must be located at least two stack or duct equivalent diameters downstream from a flow disturbance and one-half equivalent diameter upstream from a flow disturbance.

##### **3.1.2 EPA Method 2, Determination of Stack Gas Velocity and Volumetric Flow Rate (Type S Pitot Tube)**

EPA Method 2 is used to measure the gas velocity using an S-type pitot tube connected to a pressure measurement device, and to measure the gas temperature using a calibrated thermocouple connected to a thermocouple indicator. Typically, Type S (Stausscheibe) pitot tubes conforming to the geometric specifications in the test method are used, along with an inclined manometer. The measurements are made at traverse points specified by EPA Method 1.

##### **3.1.3 EPA Method 3A, Determination of Oxygen and Carbon Dioxide Concentrations in Emissions from Stationary Sources (Instrumental Analyzer Procedure)**

EPA Method 3A is an instrumental test method used to measure the concentration of O<sub>2</sub> and CO<sub>2</sub> in stack gas. The effluent gas is continuously or intermittently sampled and conveyed to analyzers that measure the concentration of O<sub>2</sub> and CO<sub>2</sub>. The performance requirements of the method must be met to validate data.

This method was modified by measuring the concentrations of O<sub>2</sub> and CO<sub>2</sub> using a continuous lung. The gas samples were analyzed for percent O<sub>2</sub> and CO<sub>2</sub> using an O<sub>2</sub>/CO<sub>2</sub> analyzer.

The typical sampling system is detailed in Figure 3-1.

**FIGURE 3-1  
 EPA METHOD 3A SAMPLING TRAIN**

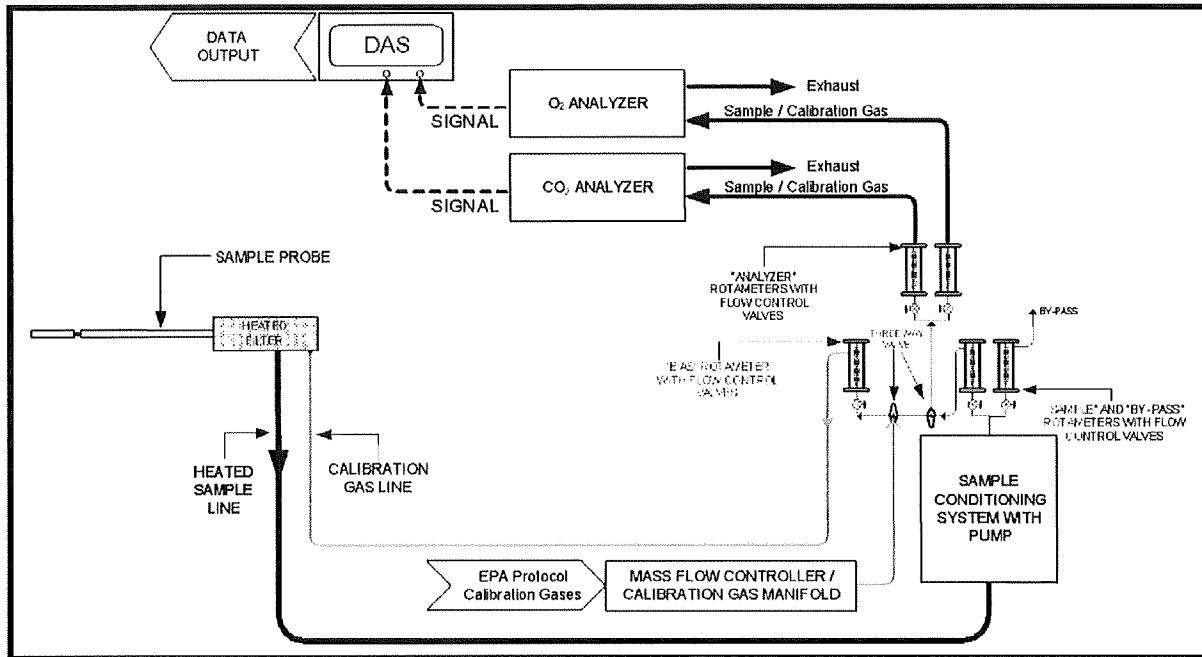

**3.1.4 EPA Method 4, Determination of Moisture Content in Stack Gas**

EPA Method 4 is a manual, non-isokinetic method used to measure the moisture content of gas streams. Gas is sampled at a constant sampling rate through a probe and impinger train. Moisture is removed using a series of pre-weighed impingers containing methodology-specific liquids and silica gel immersed in an ice water bath. The impingers are weighed after each run to determine the percent moisture.

The typical sampling system is detailed in Figure 3-2.

**3.1.5 EPA Method 5, Determination of Particulate Matter from Stationary Sources**

EPA Method 5 is a manual, isokinetic method used to measure FPM emissions. The samples are analyzed gravimetrically. This method is performed in conjunction with EPA Methods 1 through 4. The stack gas is sampled through a nozzle, probe, filter, and impinger train. FPM results are reported in emission concentration and emission rate units.

The typical sampling system is detailed in Figure 3-2.

**FIGURE 3-2  
 EPA METHOD 5 SAMPLING TRAIN**

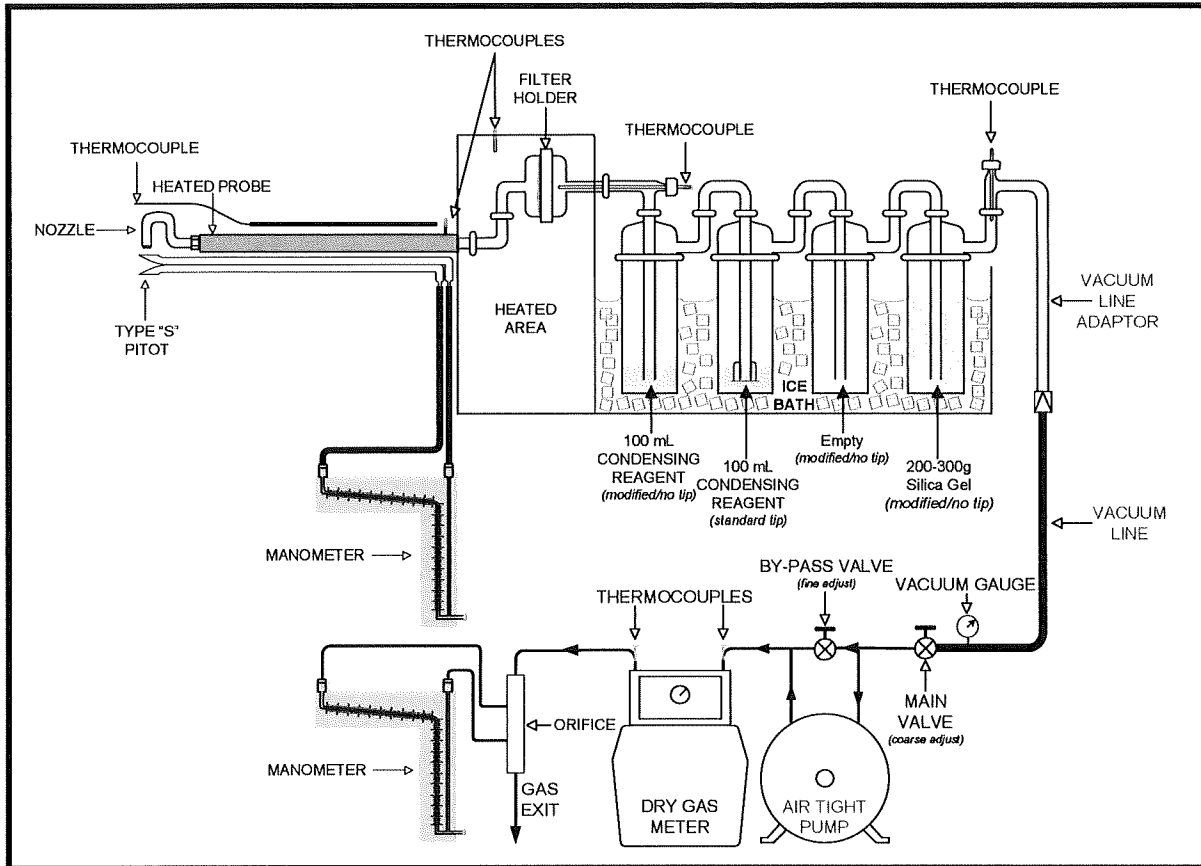

**3.1.6 EPA Method 19, Determination of Sulfur Dioxide Removal Efficiency and Particulate Matter, Sulfur Dioxide, and Nitrogen Oxide Emission Rates**

EPA Method 19 is used to calculate pollutant emission rates in units of lb/MMBtu. EPA Method 19, Table 19-2 contains a list of assigned fuel factors for different types of fuels, which can be used for these calculations.

**3.2 PROCESS TEST METHODS**

Process samples of coal were taken by DTE Energy personal and analyzed for Proximate and Ultimate fuel analysis.

## **4.0 TEST DISCUSSION AND RESULTS**

### **4.1 FIELD TEST DEVIATIONS AND EXCEPTIONS**

No field deviations or exceptions from the test plan or test methods occurred during this test program.

### **4.2 PRESENTATION OF RESULTS**

The average results are compared to the permit limits in Table 1-2. The results of individual compliance test runs performed are presented in Table 4-1. Emissions are reported in units consistent with those in the applicable regulations or requirements. Additional information is included in the appendices as presented in the Table of Contents.



**TABLE 4-1  
FILTERABLE PM EMISSIONS RESULTS -  
EU-BOILER1-BR**

Run Number	1	2	3	Average
<b>Date</b>	6/15/2021	6/15/2021	6/15/2021	--
<b>Time</b>	7:56-9:06	9:33-10:44	11:10-12:23	--
<b>Process Data</b>				
Boiler Heat Input Rate, MMBtu/hr	6101	6136	6268	6168
<b>Flue Gas Parameters</b>				
O <sub>2</sub> , % volume dry	9.38	9.33	9.28	9.33
CO <sub>2</sub> , % volume dry	10.08	9.95	9.84	9.96
flue gas temperature, °F	290.2	293.9	296.6	293.6
moisture content, % volume	11.17	10.59	11.16	10.97
volumetric flow rate, dscfm	1,746,586	1,748,260	1,778,188	1,757,678
<b>Filterable PM</b>				
gr/dscf	0.0062	0.0047	0.0053	0.0054
lb/hr	93.1	70.0	80.3	81.1
lb/MMBtu	0.015	0.011	0.013	0.013

## 5.0 INTERNAL QA/QC ACTIVITIES

### 5.1 QA/QC AUDITS

The meter box and sampling trains used during sampling performed within the requirements of their respective methods. All post-test leak checks, minimum metered volumes, minimum sample durations, and percent isokinetics met the applicable QA/QC criteria.

EPA Method 3A calibration audits were all within the measurement system performance specifications for the calibration drift checks, system calibration bias checks, and calibration error checks.

EPA Method 5 analytical QA/QC results are included in the laboratory report. The method QA/QC criteria were met, except if noted in Section 5.2. An EPA Method 5 reagent blank was analyzed. The maximum allowable amount that can be subtracted is 0.001% of the weight of the acetone blank. The blank did not exceed the maximum residue allowed.

### 5.2 QA/QC DISCUSSION

All QA/QC criteria were met during this test program.

### 5.3 QUALITY STATEMENT

Montrose is qualified to conduct this test program and has established a quality management system that led to accreditation with ASTM Standard D7036-04 (Standard Practice for Competence of Air Emission Testing Bodies). Montrose participates in annual functional assessments for conformance with D7036-04 which are conducted by the American Association for Laboratory Accreditation (A2LA). All testing performed by Montrose is supervised on site by at least one Qualified Individual (QI) as defined in D7036-04 Section 8.3.2. Data quality objectives for estimating measurement uncertainty within the documented limits in the test methods are met by using approved test protocols for each project as defined in D7036-04 Sections 7.2.1 and 12.10. Additional quality assurance information is included in the report appendices. The content of this report is modeled after the EPA Emission Measurement Center Guideline Document (GD-043).

# APPENDIX A FIELD DATA AND CALCULATIONS

## **Appendix A.1 Sampling Locations**

**EU-BOILER1-BR EXHAUST TRAVERSE POINT LOCATION DRAWING**

