

RECEIVED

OCT 09 2014

AIR QUALITY DIV.

Consumers Energy Company

**D E Karn Generating Plant
Essexville, MI**

**Units 1 and 2
Particulate Emission Test**

**Testing Conducted On:
September 3-4, 2014**

Test Conducted By:
Brian Miska and Gregg Koteskey
Consumers Energy Company
Engineering Services Department
Regulatory Compliance Testing Services



MICHIGAN DEPARTMENT OF ENVIRONMENTAL AIR QUALITY DIVISION

RENEWABLE OPERATING PERMIT REPORT CERTIFICATION

Authorized by 1994 P.A. 451, as amended. Failure to provide this information may result in civil and/or criminal penalties.

Reports submitted pursuant to R 336.1213 (Rule 213), subrules (3)(c) and/or (4)(c), of Michigan's Renewable Operating Permit (ROP) program must be certified by a responsible official. Additional information regarding the reports and documentation listed below must be kept on file for at least 5 years, as specified in Rule 213(3)(b)(ii), and be made available to the Department of Environmental Quality, Air Quality Division upon request.

Source Name Consumers Energy D.E. Karn 1&2 Plant County Bay
Source Address 2680 N. Weadock Highway City Essexville
AQD Source ID (SRN) B2840 ROP No. MI-ROP-B2840-2009a ROP Section No. 1

Please check the appropriate box(es):

Annual Compliance Certification (Pursuant to Rule 213(4)(c))
Reporting period (provide inclusive dates): From To
1. During the entire reporting period, this source was in compliance with ALL terms and conditions contained in the ROP, each term and condition of which is identified and included by this reference. The method(s) used to determine compliance is/are the method(s) specified in the ROP.
2. During the entire reporting period this source was in compliance with all terms and conditions contained in the ROP, each term and condition of which is identified and included by this reference, EXCEPT for the deviations identified on the enclosed deviation report(s). The method used to determine compliance for each term and condition is the method specified in the ROP, unless otherwise indicated and described on the enclosed deviation report(s).

Semi-Annual (or More Frequent) Report Certification (Pursuant to Rule 213(3)(c))
Reporting period (provide inclusive dates): From To
1. During the entire reporting period, ALL monitoring and associated recordkeeping requirements in the ROP were met and no deviations from these requirements or any other terms or conditions occurred.
2. During the entire reporting period, all monitoring and associated recordkeeping requirements in the ROP were met and no deviations from these requirements or any other terms or conditions occurred, EXCEPT for the deviations identified on the enclosed deviation report(s).

Other Report Certification
Reporting period (provide inclusive dates): From To
Additional monitoring reports or other applicable documents required by the ROP are attached as described:
2014 Particulate Emission Test Results Submittal

I certify that, based on information and belief formed after reasonable inquiry, the statements and information in this report and the supporting enclosures are true, accurate and complete

David T. Walter Site Production Manager I (989) 891-3158
Name of Responsible Official (print or Title Phone Number
type)

Signature of Responsible Official Date 10-08-14

* Photocopy this form as needed.

RECEIVED

OCT 09 2014

INTRODUCTION

AIR QUALITY DIV.

This report summarizes the results of the emission testing for particulate matter (PM), conducted on September 3-4, 2014, on Units 1 and 2 at Consumers Energy Company's D E Karn Generating Plant, located in Essexville, Michigan. The purpose of the emission testing was to demonstrate compliance with the PM emission limit for the units, as identified in the facility's current renewable operating permit (ROP) No. MI-ROP-B2840-2009a. The particulate test was conducted in accordance with the ROP and a stack test protocol, which was submitted on August 4, 2014. The stack test protocol was approved by Mr. Mark Dziadosz of the Michigan DEQ Technical Programs Unit on August 14, 2014. Ms. Sharon LeBlanc, Environmental Quality Analyst of the Saginaw Bay District Office was present on September 3rd and 4th to observe portions of the particulate testing on both units. Mr. David Patterson, Environmental Quality Analyst of the Technical Programs Unit, was present on September 3, 2014 to observe a portion of the particulate testing on Unit 2.

Consumers Energy Company's D E Karn Unit 1 is a 2500 million BTU per hour dry bottom tangential coal fired boiler with fuel oil startup capabilities and supplemental co-firing for flame stabilization and mill outages. Karn Unit 1 has a full load rating of 277 MW gross (260 MW net) load.

Karn Unit 2 is a 2540 million BTU per hour dry bottom wall coal fired boiler with fuel oil startup capabilities and supplemental co-firing for flame stabilization and mill outages. Karn Unit 2 has a 1,750,000 lbs/hr steam flow at its full load rating of 277 MW gross (260 MW net) load.

Both Karn Units 1 and 2 burn a blend of Eastern bituminous and Western sub-bituminous coal. The typical blend ratio for both units is 25 to 40% Eastern and 60 to 75% Western. Both Karn Units 1 and 2 utilize 6 coal pulverizing mills; each mill is rated at a maximum of 20.5 tons per hour. The actual fuel blend burned during the emissions testing is documented in Attachment 8, Fuel Analysis.

The particulate matter sampling procedure, as outlined in Reference Method 17 of 40 CFR 60, Appendix A, was followed throughout the test. In addition, equations contained in Method 5B of Michigan Rule 336.2011 were also utilized to determine the amount of excess air and correct the particulate matter concentrations to 50% excess air (Attachment 1).

SOURCE INFORMATION

TESTING FIRM INFORMATION

Consumers Energy Company
D E Karn Plant
2742 N. Weadock Highway
Essexville, MI 48732

Consumers Energy Company
Regulatory Compliance Testing Services
J.C. Weadock Plant
2555 N. Weadock Highway
Essexville, MI 48732

Contact: George Eurich (989) 891-3317

Contact: Mr. Brian Miska (989) 891-3415

SUMMARY OF RESULTS

During the testing period, Unit 1 burned approximately 23.3% Eastern coal and 76.7% Western coal. Testing was conducted as close to full load as possible (277 MW gross), with an average unit load of 255.7 MW.

During the testing period, Unit 2 burned approximately 24.3% Eastern coal and 75.7% Western coal. Testing was conducted as close to 195 MW load as possible as per the Acceptance Letter dated August 14, 2014 due to the unavailability of the unit 2C Boiler Feed Pump. Unit 2 operated at an average unit load of 212 MW during the particulate matter testing.

Testing was conducted on Units 1 and 2 in order to demonstrate compliance with the facility's current ROP (No. MI-ROP-B2840-2009a) particulate matter emission limit. The particulate emission limit for these units is specified in Condition I.2 of EUKARN1-S1 and EUKARN2-S1 Emission Unit Conditions. The permitted limit for particulate matter is summarized below in Table 1.

Table 1 – Summary of EUKARN1-S1 and EUKARN2-S1 PM Emission Limit

Pollutant	Limit
PM	0.16 pounds per 1,000 pounds exhaust gas, corrected to 50% excess air.

As shown in Table 2 below, each individual run, as well as the average particulate emission rate, was below the emission limit of 0.16 pounds per 1,000 pounds for Unit 1. Thus, Unit 1 is in compliance with the ROP particulate matter emission limit.

Table 2 - Summary of Unit 1 PM Emission Test Results

Run Number	Gas Volume (acfm)	Outlet Grain Loading (gr/dscf)	Particulate Concentration (lb/mmBtu)	Particulate Concentration (lb/hr)	Lb/1,000 lbs Gas Flow*
Run 1	876,940	0.0004	0.0008	2.2214	0.0007
Run 2	861,994	0.0004	0.0007	1.8201	0.0005
Run 3	859,156	0.0006	0.0011	2.8217	0.0008
Average	866,030	0.0005	0.0009	2.2877	0.0007

*Emissions in pounds of particulate per 1,000 pounds gas flow, corrected to 50% excess air.

As shown in Table 3 below, each individual run, as well as the average particulate emission rate, was below the emission limit of 0.16 pounds per 1,000 pounds for Unit 2. Thus, Unit 2 is in compliance with the ROP particulate matter emission limit.

Table 3 - Summary of Unit 2 PM Emission Test Results

Run Number	Gas Volume (acfm)	Outlet Grain Loading (gr/dscf)	Particulate Concentration (lb/mmBtu)	Particulate Concentration (lb/hr)	Lb/1,000 lbs Gas Flow*
Run 1	860,961	0.0000	0.0000	0.0000	0.0000
Run 2	862,249	0.0001	0.0001	0.2277	0.0001
Run 3	865,996	0.0002	0.0003	0.6889	0.0003
Average	863,069	0.0001	0.0002	0.3055	0.0001

*Emissions in pounds of particulate per 1,000 pounds gas flow, corrected to 50% excess air.

SOURCE DESCRIPTION

Karn Unit 1 is a 2500 million BTU per hour dry bottom tangential coal fired boiler with fuel oil startup capabilities and supplemental co-firing for flame stabilization and mill outages. Karn Unit 1 has a full load rating of 277 MW gross, and 260 MW net.

Karn Unit 1 burns a blend of Eastern bituminous and Western sub-bituminous coal. A typical blend ratio for this unit is 25% Eastern and 75% Western. The unit burned 23.3% Eastern coal and 76.7% Western coal the day that testing was performed.

Karn Unit 2 is a 2540 million BTU per hour dry bottom tangential coal fired boiler with fuel oil startup capabilities and supplemental co-firing for flame stabilization and mill outages. Karn Unit 2 has a 1,750,000 lbs/hr steam flow at full load rating of 277 MW gross, and 260 MW net.

Karn Unit 2 burns a blend of Eastern bituminous and Western sub-bituminous coal. A typical blend ratio for this unit is 25% Eastern and 75% Western. The unit burned 24.3% Eastern coal and 75.7% Western coal the day that testing was performed.

Both Karn Units 1 and 2 utilize 6 coal pulverizing mills; each mill is rated at a maximum of 20.5 Tons per hour. Coal quality and blend ratio burned during the testing is documented for both units in Attachment 8, Fuel Analysis.

POLLUTION CONTROL EQUIPMENT

Particulate emissions from Karn Units 1 and 2 are controlled with low pressure/high volume pulse jet fabric filters (PJFF). The PJFF controls flyash particulate emissions from the boiler. As flue gas leaves the boiler, it enters the PJFF through interconnecting duct work, and an inlet manifold distributes the gas into compartments where fabric filter bags are held. As the flue gas enters the compartments, the gas velocity decreases and some of the larger particles fall into the ash hopper. The remainder of the particulate laden flue gas passes through the fabric filter bag, accumulating the particulate on the exterior surface of the filter bags. The filtered flue gas leaves each compartment into the clean side outlet plenum and through the outlet ductwork to the Unit ID fan for discharge to the atmosphere through the stack.

Each PJFF has 10 compartments that hold 1,016 bags per compartment, for a total of 10,160 bags; this provides a total cloth area of 320,950 sq. ft.

Karn Units 1 and 2 have a Selective Catalytic Reduction (SCR) system for the control of nitrogen oxides (NOX).

Karn Unit 2 has low NOX burners for additional control of nitrogen oxides (NOX).

Karn Unit 1 utilizes a Spray Dry Absorber (SDA) system for the control of Sulfur Dioxide (SO₂) which has been in service since May 2014. The Karn Unit 2 Spray Dry Absorber is currently under construction with an anticipated completion date of December 2014 or January 2015.

SAMPLING AND ANALYTICAL PROCEDURES

The procedures described within Section 11.4 of Method 1 (40 CFR Part 60, Appendix A) were used to verify the absence of cyclonic flow in the stacks during tests conducted in 2005 (see Attachment 2). The average yaw null angle for Unit 1 was 4 degrees and Unit 2 was 3 degrees, which are within the tolerance for cyclonic flow. No changes have been made to the stacks since the date these tests were conducted; therefore, the cyclonic flow data is still valid and additional cyclonic flow tests were not conducted prior to the particulate matter testing.

The PM sampling procedure, as outlined in Reference Method 17 of 40 CFR 60, Appendix A, was followed throughout the test. In addition, equations contained in Method 5B of Michigan Rule 336.2011 were also utilized to determine the amount of excess air and to correct the PM concentration to 50% excess air.

Testing on Unit 1 was conducted as close to full load as possible (277 MW gross), with an average unit load of 255.7 MW. Soot blowing and ash removal occurred as normal during the testing, with at least one soot blow occurring during one test run for Unit 1. A coal sample was taken during the test, as required.

Testing on Unit 2 was conducted as close to 195 MW as possible due to the unavailability of the unit 2C Boiler Feed Pump, with an average unit load of 212 MW. Soot blowing and ash removal occurred as normal during the testing, with at least one soot blow occurring during one test run for Unit 2. A coal sample was taken during the test, as required.

Plant operating data that was collected during the test periods included gross load (in megawatts), steam flow (in 1,000 lbs/hr), CO₂ (in percent), NO_x (in lbs/MMBTU), SO₂ (in lbs/MMBTU), temperature, and percent stack opacity. This data is presented in Attachment 6 for Unit 1, and Attachment 7 for Unit 2. The proximate analysis results for the coal fired during the test are presented in Attachment 8.

Three PM runs were performed to constitute a complete test for both units. Each run included a minimum 3 minutes of sampling at each of 24 points for a total of no less than 72 minutes per run. This resulted in sample volumes greater than 30 DSCF with the exception of the first run on Unit 2, which is detailed below.

During the first Particulate Test run on Karn Unit 2, the sample time was 3 minutes per point, 18 minutes per port. In previous particulate testing of Unit 2, the unit load was over 250 MW and the use of a 3/16 inch diameter nozzle with a sampling duration of 3 minutes per point was sufficient to collect a volume of 30 DSCF. However, this year's test was performed at the unit load of 212 MW, due to 2C Boiler Feed Pump being out of service. The reduced unit load reduced the stack velocity, which resulted in a sample volume of 26.30 DSCF after 72 minutes of testing, which was less than the target of 30 DSCF.

The sample volume data from the first run on Unit 2 was shown to Mr. David Patterson from the MDEQ and permission to use the data as test run 1 was requested. Mr. Patterson granted permission to use the data. The sample time was increased to 3.5 minutes per point for runs 2 and 3, which resulted in sample volumes over 30 DSCF at the end of the 84 minute test run.

The cross-section at the sampling site is divided into equal areas as defined in Method 1 (see Figures 3a and 3b for Units 1 and 2 respectively). The particulate matter was collected isokinetically from the gas stream and the weight determined on a dry basis. The isokinetic variation on the tests performed is shown on the summary sheet in the post-test report (Attachment 2 for Unit 1, Attachment 3 for Unit 2). The allowable range according to Method 17 is $100\% \pm 10\%$.

A flow diagram of the sampling train is attached to this report (see Figure 2a). A sample nozzle was connected to the primary filter housing, followed by a secondary filter. This assembly was connected to a probe extension (see Figure 3) which is connected to a moisture trap (Figure 2b). This was followed by a leak free Method 17 test module.

A type "S" Pitot tube was attached to the probe to measure the stack gas velocity. Temperature measurements were collected using a digital indicator and thermocouple wire which was attached to the Pitot tube.

Moisture was determined using Reference Method 4, 40 CFR Part 60, Appendix A.

Analysis of the flue gas was performed by Reference Method 3A, 40 CFR Part 60, Appendix A. A Servomex O₂/CO₂ analyzer was used.

Before sampling was started, a pre-weighed glass fiber filter and back-up filter were placed in the filter housing assembly. One hundred milliliters (100ml) of water was put into the first chamber of the moisture trap. The second chamber of the moisture trap was left empty, and the third chamber of the moisture trap was partially filled with indicating-type silica gel desiccant and weighed. The sample train was then assembled and leak-checked at 15" HG vacuum. At this time, the pitot tube assembly was also leak checked.

The isokinetic meter rate was calculated at each traverse point by entering the differential pressure and temperature into a computer spreadsheet. Adjustment of the sampling rate was made by using a calibrated orifice at the discharge of the dry gas meter. Field data was recorded on the computer spreadsheet at each sample point.

Extreme care was exercised during the sample recovery period. The collected condensate in the moisture trap was measured and recorded. The filter assembly was removed and disassembled in the laboratory. The primary and back-up filters were both dried for the same duration and at the same temperature that they were subjected to prior to the sample collection. The filters were then weighed to determine the net weight of the particulate matter that was collected on the filter media. The nozzle of the sample probe was washed with deionized water (in lieu of acetone) and the wash water captured into a pre-weighed beaker. The wash water was then evaporated from the beaker and the beaker was then re-weighed. Any weight gain measured from the beakers initial weight was added to the particulate matter weight of the primary and secondary glass fiber filters.

D E KARN UNITS 1 & 2

PARTICULATE EMISSION TEST

SUMMARY TABLE

Date	Unit	Gross MW	Steam Flow (klb/hr)	Gas Volume (acfm)	Outlet Grain Loading (gr/dscf)	Particulate Concentration (lb/mm btu)	Particulate Concentration (lb/hr)	lb/1000 lbs Gas Flow *	Average Stack Opacity (%)	Flue Gas Temp (°F)	Flue Gas Velocity (fps)	Excess Air (%)	Flue Gas Moisture (%)	Isokinetic Variation (%)
9/4/2014	1	255	1657.8	876,940	0.0004	0.0008	2.2214	0.0007	1	182.8	37.3	38.4	16.2	98.6
9/4/2014	1	256	1665.7	861,994	0.0004	0.0007	1.8201	0.0005	1	183.0	36.6	37.1	16.4	98.3
9/4/2014	1	256	1669.9	859,156	0.0006	0.0011	2.8217	0.0008	1	183.3	36.5	37.7	16.2	98.2
Average		255.7	1664.5	866,030	0.0005	0.0009	2.2877	0.0007	1.0	183.0	36.8	37.7	16.3	98.4
9/3/2014	2	212	1326.3	860,961	0.0000	0.0000	0.0000	0.0000	2	311.6	56.4	57.9	9.9	93.5
9/3/2014	2	212	1323.8	862,249	0.0001	0.0001	0.2277	0.0001	2	314.7	56.5	57.7	10.0	92.3
9/3/2014	2	212	1334.7	865,996	0.0002	0.0003	0.6889	0.0003	2	315.3	56.7	57.9	9.7	91.5
Average		212	1328.27	863,069	0.0001	0.0002	0.3055	0.0001	2.0	313.9	56.5	57.8	9.9	92.4

* Emissions in pounds of particulate per 1000 pounds gas flow corrected to 50 % excess air.

- Notes:
1. The particulate emission limit is 0.16 lbs/1,000 lbs gas flow at 50% excess air for Units 1 and 2.
 2. Oxygen and carbon dioxide are measured at the point of particulate sampling.
 3. Flue gas moisture is determined by the condensate method.
 4. Flue gas temperature is the average temperature at the point of particulate sampling.

COAL ANALYSIS
(on dry basis)

Date	Unit	% Moisture	% Ash	% Sulfur	Btu
9/4/2014	1	23	8.65	0.58	12,485
9/4/2014	1	23	8.65	0.58	12,485
9/4/2014	1	23	8.65	0.58	12,485
9/3/2014	2	23.7	8.22	0.55	12,460
9/3/2014	2	23.7	8.22	0.55	12,460
9/3/2014	2	23.7	8.22	0.55	12,460

FIGURES

Figure 1
DE KARN PLANT UNITS 1 & 2
IN-STOCK TEST PORT LOCATION
 (elevation looking East)

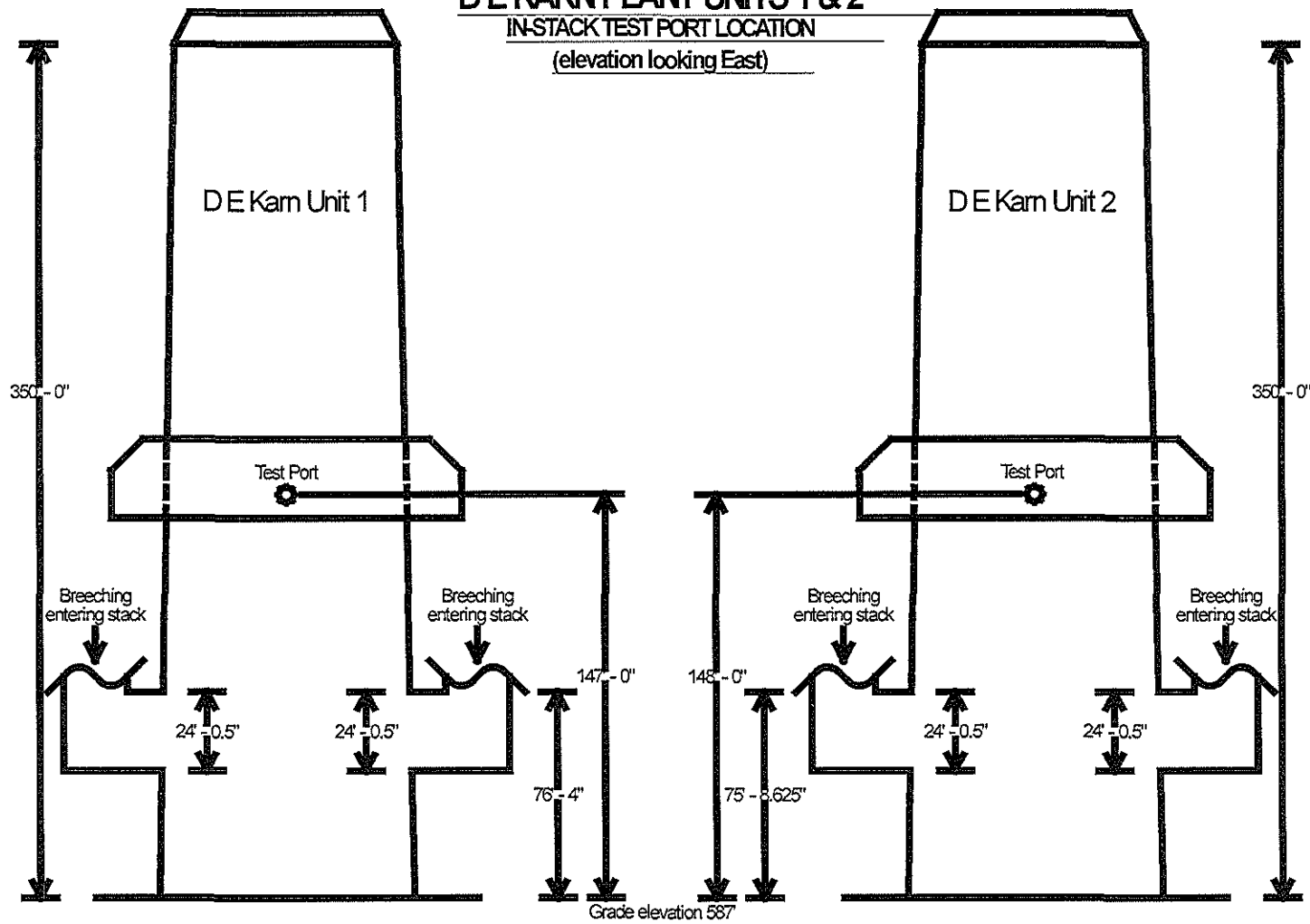

METHOD 17 SAMPLE TRAIN FLOW DIAGRAM

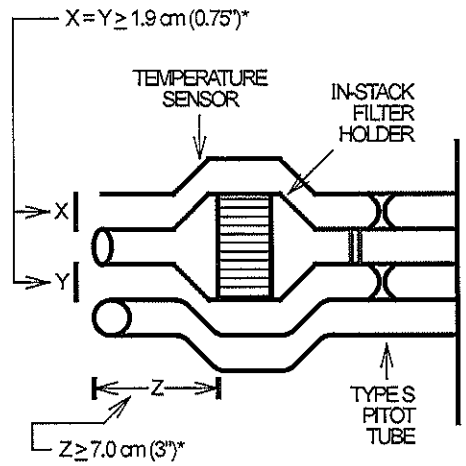
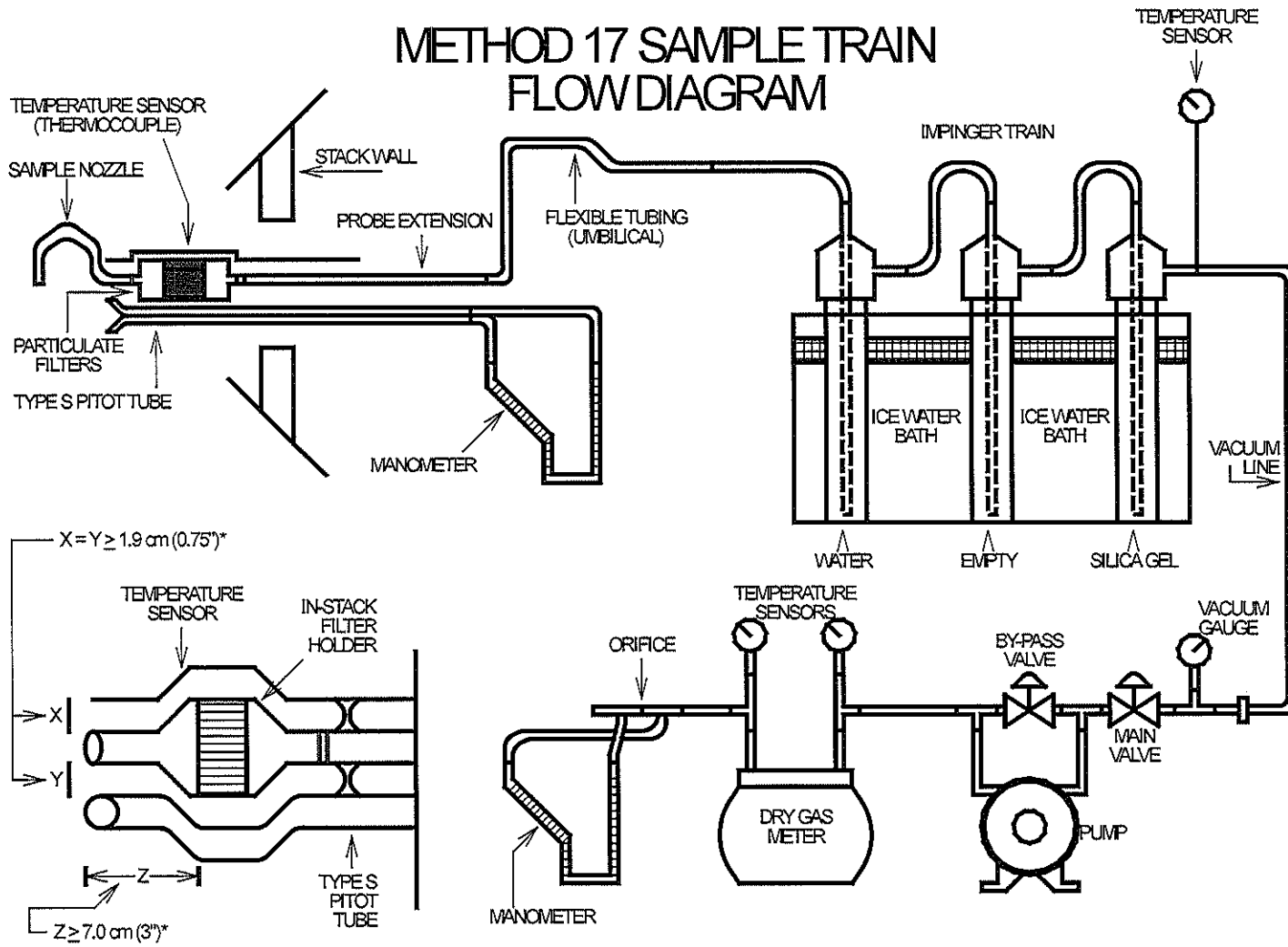

*SUGGESTED (INTERFERENCE FREE) SPACINGS

Figure 2a

Figure 2b

METHOD 17 PROBE ASSEMBLY DIAGRAM

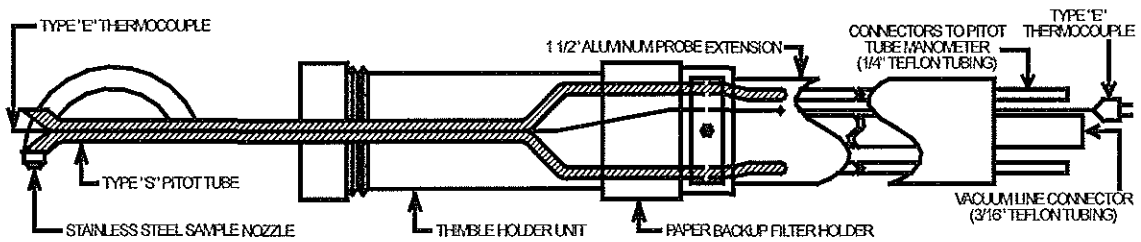
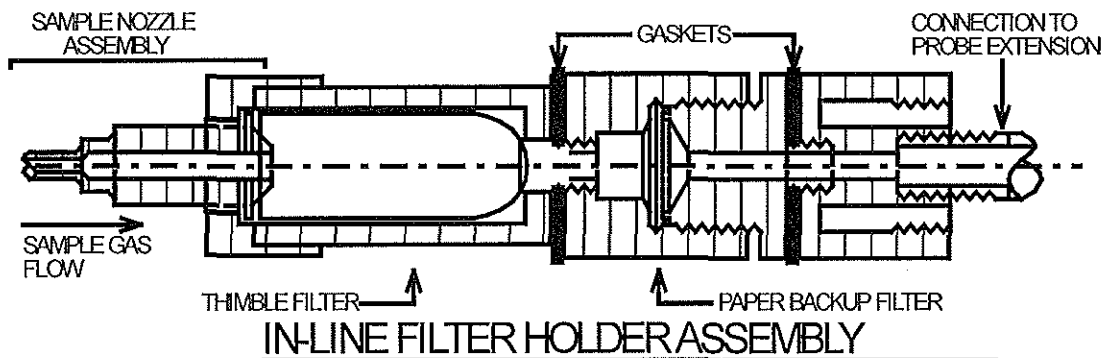
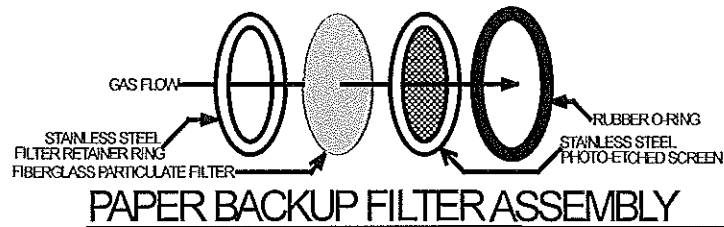
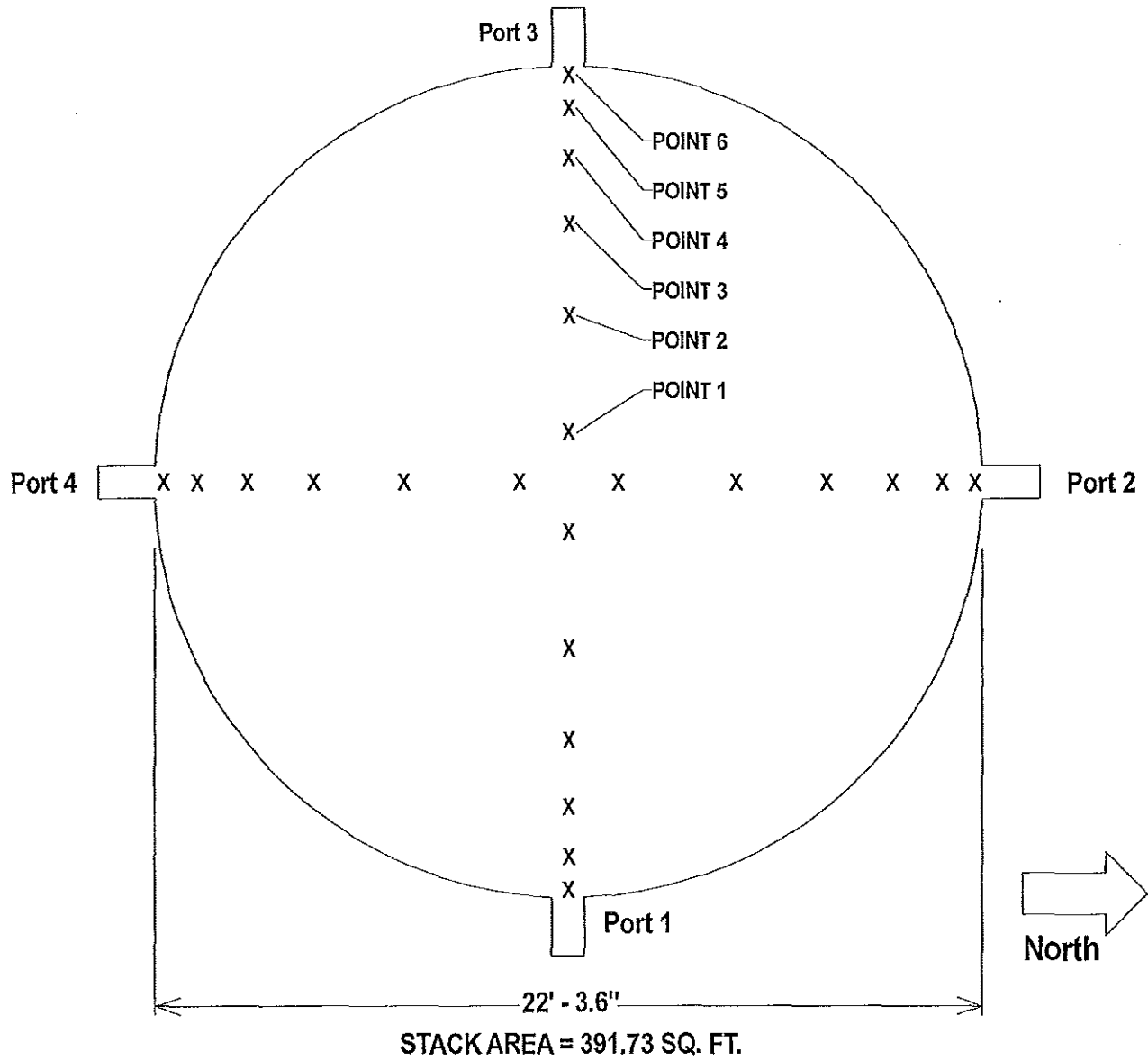

Figure 3

D E KARN UNIT 1 PARTICULATE EMISSION TEST POINT LOCATIONS



PARTICULATE EMISSION TEST POINT LOCATIONS

Note: Test Port Length = 24" from inside stack wall to outside flange.

DISTANCES FROM INSIDE STACK WALL

Point 1	95.27"
Point 2	66.90"
Point 3	47.37"
Point 4	31.58"
Point 5	17.93"
Point 6	5.62"

Figure 4
D E KARN UNIT 2 PARTICULATE EMISSION TEST POINT LOCATIONS

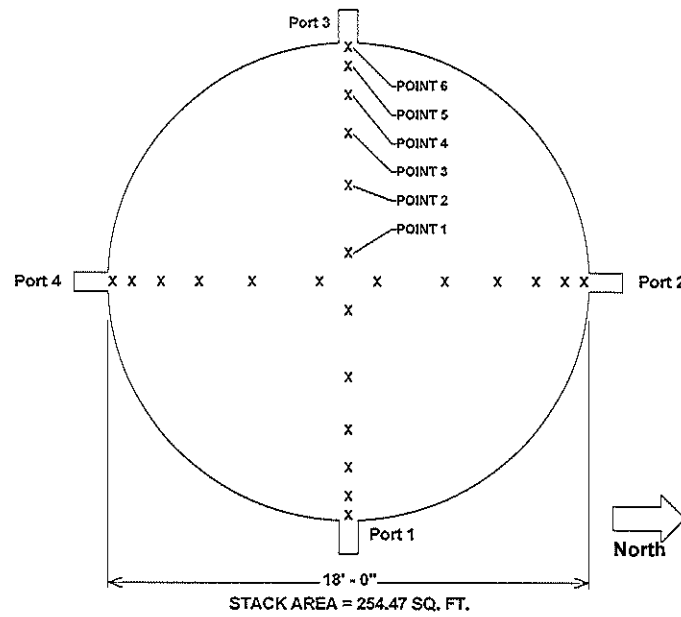

PARTICULATE EMISSION TEST POINT LOCATIONS
 Note: Test Port Length = 14" from inside stack wall to outside flange.
 DISTANCES FROM INSIDE STACK WALL

Point 1	76.90"
Point 2	54.00"
Point 3	38.23"
Point 4	25.49"
Point 5	14.47"
Point 6	4.54"