

**SOURCE TEST REPORT
2021 COMPLIANCE TESTING
CORTEVA AGRISCIENCE LLC
HARBOR BEACH OPERATIONS
MI-ROP-B4942
HARBOR BEACH, MICHIGAN**

Prepared For:

Corteva Agriscience LLC

SRN B4942

305 North Huron Ave
Harbor Beach, MI 48441

For Submittal To:

Environment, Great Lakes, and Energy

525 W Allegan St
Lansing, Michigan 48933

Prepared By:

Montrose Air Quality Services, LLC

4949 Fernlee Avenue
Royal Oak, Michigan 48073

Document Number: **M049AS-007484-RT-824**
Test Dates: **July 27-29, 2021**
Submittal Date: **September 29, 2021**

RECEIVED

OCT 04 2021

AIR QUALITY DIVISION



TABLE OF CONTENTS

<u>SECTION</u>	<u>PAGE</u>
1.0 INTRODUCTION	5
1.1 SUMMARY OF TEST PROGRAM	5
1.2 KEY PERSONNEL	14
2.0 PLANT AND SAMPLING LOCATION DESCRIPTIONS	16
2.1 PROCESS DESCRIPTION, OPERATION, AND CONTROL EQUIPMENT	16
2.2 FLUE GAS SAMPLING LOCATIONS	17
2.3 OPERATING CONDITIONS AND PROCESS DATA	18
3.0 SAMPLING AND ANALYTICAL PROCEDURES	20
3.1 TEST METHODS	20
3.1 TTU TEST METHODS	20
3.1.1 EPA Method 1	20
3.1.2 EPA Method 2	20
3.1.3 EPA Method 3A	21
3.1.4 EPA Method 4	22
3.1.5 EPA Method 5	23
3.1.6 EPA Method 25A	24
3.1.7 EPA Method 320	25
3.2 FLARE TEST METHODS	26
3.2.1 EPA Alt-080/073	26
3.2.2 EPA Method 22	26
3.2.3 ASTM D1946-90	27
3.3 Wastewater Treatment Unit Test Methods	27
4.0 TEST DISCUSSION AND RESULTS	29
4.1 FIELD TEST DEVIATIONS AND EXCEPTIONS	29
4.2 PRESENTATION OF RESULTS	29
5.0 INTERNAL QA/QC ACTIVITIES	41
5.1 QA/QC AUDITS	41
5.2 QA/QC DISCUSSION	41
5.3 QUALITY STATEMENT	42
 LIST OF APPENDICES	
A FIELD DATA	43
B FACILITY PROCESS DATA	191
C LABORATORY ANALYSIS DATA	207
D FTIR REPORT	618
E EXAMPLE CALCULATIONS	779

LIST OF TABLES

1-1 SUMMARY OF TEST PROGRAM6
1-2 SUMMARY OF AVERAGE COMPLIANCE RESULTS - TTU 8508
1-3 SUMMARY OF AVERAGE COMPLIANCE RESULTS - TTU 8559
1-4 SUMMARY OF AVERAGE COMPLIANCE RESULTS - TTU 86010
1-5 SUMMARY OF AVERAGE COMPLIANCE RESULTS - TTU 86511
1-6 SUMMARY OF AVERAGE COMPLIANCE RESULTS - TTU 87012
1-7 SUMMARY OF AVERAGE COMPLIANCE RESULTS - TTU 870 (condition 2).....13
1-3 TEST PERSONNEL AND OBSERVERS15
2-1 SAMPLING LOCATIONS18
4-1 TTU 850 Vapor Phase30
4-2 TTU 850 PM31
4-3 TTU 855 Vapor Phase32
4-4 TTU 855 PM33
4-5 TTU 860 Vapor Phase34
4-6 TTU 860 PM35
4-7 TTU 865 Vapor Phase36
4-8 TTU 865 PM37
4-9 TTU 870 Vapor Phase38
4-10 TTU 870 PM39
4-11 TTU 870 PM Condition 240

LIST OF FIGURES

3-1 US EPA METHOD 2 SAMPLING TRAIN23
3-2 EPA METHODS 3A (O₂), 25A SAMPLING TRAIN22
3-3 US EPA METHOD 5 SAMPLING TRAIN27
3-4 US EPA METHOD 320 SAMPLING TRAIN.....29

1.0 INTRODUCTION

1.1 SUMMARY OF TEST PROGRAM

Corteva Agriscience (Corteva) contracted Montrose Air Quality Services, LLC (Montrose) to perform a compliance emissions test program on the TTU 850, TTU 855, TTU 860, TTU 865, and TTU 870 at the Harbor Beach facility located in Harbor Beach, Michigan. The tests were conducted to demonstrate ongoing compliance with the Pesticide Active Ingredient (PAI) MACT (40CFR63, Subpart MMM) emission standards. To comply with this standard, organic hazardous air pollutant (OHAP) emissions are maintained below 20 ppmv OHAP using catalytic incineration and thermal oxidation as controls. Measurements will also be collected to assess compliance with MI-ROP-B4942-2020a EU_PROCESS emission limits and to support emission factors used to develop emission estimates used in Michigan Air Emission Reporting System (MAERS) and EPCRA TRI reporting.

The specific objectives were to:

- Measure VOC, PM, MeOH, CH₂O, NH₃, NO_x, and CO from the TTU Outlet Sources listed in this test plan as condition 1 (see Section 2.3.1)
- Measure PM from the TTU Outlet Sources listed in the test plan as condition 2 (see Section 2.3.2)
- Measure MeOH from both the TTU inlet and outlet Sources in order to determine the DRE%.
- Conduct the test program with a focus on safety

Montrose performed the tests to measure the emission parameters listed in Table 1-1.

Corteva Agriscience – Harbor Beach Operations
2021 Compliance Source Test Report

**TABLE 1-1
SUMMARY OF TEST PROGRAM**

Test Date(s)	Unit ID/ Source Name	Activity/ Parameters	Test Methods	No. of Runs	Duration (Minutes)
Week of 7/26/2021	TTUs	Velocity/Volumetric Flow Rate	EPA 1 & 2	3/unit	60
Week of 7/26/2021	TTUs	O ₂ , CO ₂	EPA 3A	3/unit	60
Week of 7/26/2021	TTUs	Moisture	EPA 4	3/unit	60
Week of 7/26/2021	TTUs (2 conditions)	FPM	EPA 5	3/unit	60
Week of 7/26/2021	TTUs	NO _x	EPA 7E	3/unit	60
Week of 7/26/2021	TTUs	CO	EPA 10	3/unit	60
Week of 7/26/2021	TTUs	VOC	EPA 25A	3/unit	60
Week of 7/26/2021	TTUs	MeOH and CH ₂ O	EPA 320	3/unit	60
Week of 7/26/2021	TTUs	NH ₃	EPA 320	3/unit	60
Week of 7/26/2021	TTUs	Post-test meter calibration check	EPA ALT- 009	--	--
Week of 7/26/2021	TTUs	Post-test thermocouple calibration check	EPA ALT- 011	--	--
Week of 7/26/2021	Flare	Inlet flow rate	EPA ALT080/073		
Week of 7/26/2021	Flare	Visible Emissions	EPA 22		120
Week of 7/26/2021	Flare	TOC	ASTM D1946-90	3	60

Corteva Agriscience – Harbor Beach Operations
2021 Compliance Source Test Report

Week of 7/26/2021	WWTU	Volatiles (MeOH, Xylenes)	See section 3.3	3	60 (composite)
Week of 7/26/2021	WWTU	Semi Volatiles (Trimethylbenzene, Formic Acid)	See section 3.3	3	60 (composite)
Week of 7/26/2021	WWTU	Ammonia	See section 3.3	3	60 (composite)
Week of 7/26/2021	WWTU	Total Sulfates	See section 3.3	3	60 (composite)
Week of 7/26/2021	TTUs	Velocity/Volumetric Flow Rate	EPA 1 & 2	3/unit	60
Week of 7/26/2021	TTUs	O ₂ , CO ₂	EPA 3A	3/unit	60
Week of 7/26/2021	TTUs	Moisture	EPA 4	3/unit	60
Week of 7/26/2021	TTUs (2 conditions)	FPM	EPA 5	3/unit	60
Week of 7/26/2021	TTUs	NO _x	EPA 7E	3/unit	60

This report presents the test results and supporting data, descriptions of the testing procedures, descriptions of the facility and sampling locations, and a summary of the quality assurance procedures used by Montrose. The average emission test results are summarized and compared to their respective permit limits in Table 1-2. Detailed results for individual test runs can be found in Tables 4-1 thru 4-11. All supporting data can be found in the appendices.

The testing was conducted by the Montrose personnel listed in Table 1-3. The tests were conducted according to the test plan (protocol) dated June 18, 2021 that was submitted to and approved by the EGLE.

TABLE 1-2
SUMMARY OF AVERAGE COMPLIANCE RESULTS -
TTU 850
July 29, 2021

Parameter/Units	Average Results	Emission Limits
Filterable Particulate Matter		
Lb/1000lb dry exhaust gas	.001	.006
lb/hr	0.088	
Nitrogen Oxides (NO_x as NO₂)		
ppmvd	12.6	
lb/hr	1.6	
Carbon Monoxide (CO)		
ppmvd	1.2	
lb/hr	0.1	
Total Hydrocarbons, as Methane (VOC)		
ppmvd	10.4	
lb/hr	0.5	10.4
Ammonia (NH₃)		
ppmvd	0.03	
lb/hr	0.002	31
Formaldehyde (CH₂O)		
ppmvd	23.0	
lb/hr	2.0	
Methanol (MeOH)		
ppmvd	13.9	20
lb/hr	1.3	
DRE	94.9	>98%

**TABLE 1-3
 SUMMARY OF AVERAGE COMPLIANCE RESULTS -
 TTU 855
 July 29, 2021**

Parameter/Units	Average Results	Emission Limits
Filterable Particulate Matter		
Lb/1000lb dry exhaust gas	.0006	.006
lb/hr	0.062	
Nitrogen Oxides (NO_x as NO₂)		
ppmvd	10.7	
lb/hr	1.7	
Carbon Monoxide (CO)		
ppmvd	0.5	
lb/hr	0.1	
Total Hydrocarbons, as Methane (VOC)		
ppmv	8.8	
lb/hr	0.5	10.4
Ammonia (NH₃)		
ppmv	0.2	
lb/hr	0.01	31
Formaldehyde (CH₂O)		
ppmv	7.0	
lb/hr	0.8	
Methanol (MeOH)		
ppmv	3.9	20
lb/hr	0.5	
DRE	98.8	>98%

TABLE 1-4
SUMMARY OF AVERAGE COMPLIANCE RESULTS -
TTU 860
July 28, 2021

Parameter/Units	Average Results	Emission Limits
Filterable Particulate Matter		
Lb/1000lb dry exhaust gas	.001	.006
lb/hr	0.093	
Nitrogen Oxides (NO_x as NO₂)		
ppmvd	12.8	
lb/hr	1.8	
Carbon Monoxide (CO)		
ppmvd	0.5	
lb/hr	0.04	
Total Hydrocarbons, as Methane (VOC)		
ppmv	3.5	
lb/hr	0.1	10.4
Ammonia (NH₃)		
ppmv	0.2	
lb/hr	0.01	31
Formaldehyde (CH₂O)		
ppmv	1.7	
lb/hr	0.2	
Methanol (MeOH)		
ppmv	1.2	20
lb/hr	0.1	
DRE	99.6	>98%

RECEIVED

OCT 04 2021

AIR QUALITY DIVISION

TABLE 1-5
 SUMMARY OF AVERAGE COMPLIANCE RESULTS
 TTU 865
 July 27, 2021

Parameter/Units	Average Results	Emission Limits
Filterable Particulate Matter		
Lb/1000lb dry exhaust gas	.002	.006
lb/hr	0.227	
Nitrogen Oxides (NO_x as NO₂)		
ppmvd	21.0	
lb/hr	3.0	
Carbon Monoxide (CO)		
ppmvd	1.7	
lb/hr	0.2	
Total Hydrocarbons, as Methane (VOC)		
ppmv	7.7	
lb/hr	0.4	10.4
Ammonia (NH₃)		
ppmv	0.2	
lb/hr	0.01	31
Formaldehyde (CH₂O)		
ppmv	3.1	
lb/hr	0.3	
Methanol (MeOH)		
ppmv	2.8	20
lb/hr	0.3	
DRE	99.0	>98%

TABLE 1-6
SUMMARY OF AVERAGE COMPLIANCE RESULTS -
TTU 870
July 28, 2021

Parameter/Units	Average Results	Emission Limits
Filterable Particulate Matter		
lb/1000lb dry exhaust gas	.003	.006
lb/hr	0.467	
Nitrogen Oxides (NO_x as NO₂)		
ppmvd	7.6	
lb/hr	1.9	
Carbon Monoxide (CO)		
ppmvd	67.1	
lb/hr	10.4	
Total Hydrocarbons, as Methane (VOC)		
ppmv	6.9	
lb/hr	0.6	10.4
Ammonia (NH₃)		
ppmv	3.3	
lb/hr	0.32	31
Formaldehyde (CH₂O)		
ppmv	2.3	
lb/hr	0.4	
Methanol (MeOH)		
ppmv	9.4	20
lb/hr	1.8	
DRE	95.3	>98%

TABLE 1-7
SUMMARY OF AVERAGE COMPLIANCE RESULTS -
TTU 870 (condition 2)
July 27, 2021

Parameter/Units	Average Results	Emission Limits
Filterable Particulate Matter		
lb/1000lb dry exhaust gas	.005	.006
lb/hr	0.511	

1.2 KEY PERSONNEL

A list of project participants is included below:

Facility Information

Source Location: Corteva Agriscience LLC
Harbor Beach Operations
305 N Huron Ave
Harbor Beach, MI 48441

Project Contact: Jim McGee
Role: Environmental Manager
Company: Corteva Agriscience LLC
Telephone: 989-479-5283
Email: james.mcgee@corteva.com

Agency Information

Regulatory Agency: EGLE
Agency Contact: Karen Kajiya-Mills
Telephone: 517-256-0880
Email: kajiya-millsk@michigan.gov

Testing Company Information

Testing Firm: Montrose Air Quality Services, LLC (Montrose)
Contact: Matthew Young
Title: District Manager
Telephone: 586-744-9133
Email: myoung@montrose-env.com

Laboratory Information

Laboratory: Enthalpy Analytical
City, State: Durham, NC

Laboratory: Montrose Detroit
City, State: Royal Oak, MI

Laboratory: Montrose Mt Pleasant
City, State: Mt Pleasant, MI

Test personnel and observers are summarized in Table 1-3.

**TABLE 1-3
 TEST PERSONNEL AND OBSERVERS**

Name	Affiliation	Role/Responsibility
Matthew Young	Montrose	Project Manager
Barry Boulianne	Montrose	Project Manager
Trevor Tilman	Montrose	FTIR Operator
Cody Schifflet	Montrose	FTIR Operator
Mike Nummer	Montrose	Field Team
Shawn Jaworski	Montrose	Field Team
Shane Rabideau	Montrose	Observer
Dave Koponen	Montrose	Observer
Jim McGee	Corteva	Client Liaison
Scott Grekowicz	Corteva	Client Liaison
Lindsay Wells	EGLE	Observer
Adam Shaffer	EGLE	Observer

2.0 PLANT AND SAMPLING LOCATION DESCRIPTIONS

2.1 PROCESS DESCRIPTION, OPERATION, AND CONTROL EQUIPMENT

2.1.1 Thermal Treatment Units

The EU_PROCESS emissions are collected in multiple vent headers and routed to five Thermal Treatment Units (TTUs). The five TTUs include four catalytic thermal treatment units and a regenerative thermal oxidizer (RTO). The five TTUs are the air pollution control equipment for the EU_PROCESS.

Prior to venting to the atmosphere, fermentation, crystallization, and packaging process vents are controlled by one of the five. The 4 catalytic units currently operate at a minimum firebox temperature of 650°F. The typical process vent organic load results in small positive to negligible temperature differentials. As a result, a significant number of temperature differential measurements are within accuracy range of the temperature monitoring devices. This challenge makes establishing a catalytic bed temperature differential operating parameter difficult. An AMR was submitted and approved to address this challenge. During this test, the minimum firebox temperature operating parameter will be verified.

Typical natural gas rates to the catalytic units are approximately 80-150 scfm and exhaust stack flows of approximately 20,000 dscfm. The RTO TTU average rated heat input is approximately 3.8 MMBtu/hr and an approximate process air flow of 35,000 scfm

The TTUs primary function is to control VOC. VOC may include MeOH, Organic acids, and cyclical volatiles. Ammonia may also be present in process vents composition.

The photo below depicts the four catalytic units and the 5th RTO unit. TTU 850 is the southernmost unit. TTU 870 is located just north of TTU 865. Each Catalytic unit has a stack with a 48-inch diameter at the sampling location, while TTU 870 has a rectangular 36"x78" stack exhaust. Each of the catalytic units has two ports that are orthogonal to each other while TTU 870 has 4 horizontal ports across the 78" side.

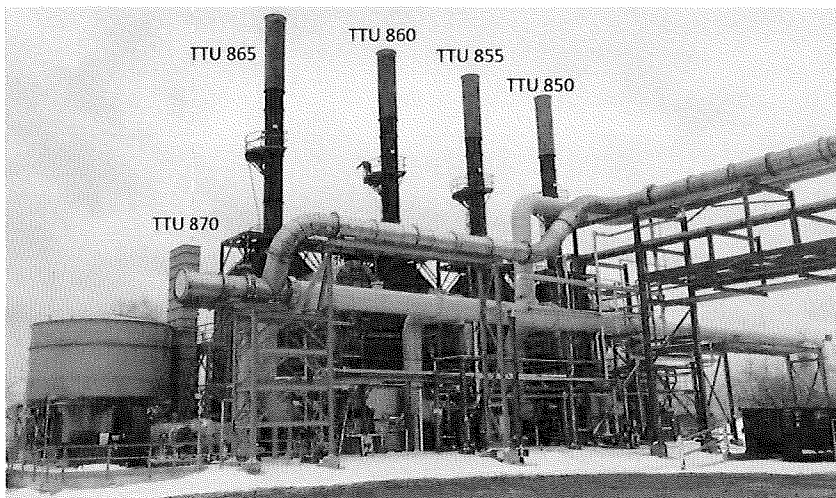

2.1.2 Flare (enclosed, unassisted)

Wastewater from the PAI process unit is directed to a closed anaerobic biological treatment process (Bioreactor R-722) to reduce the chemical oxygen demand (COD) and remove methanol. Bioreactor R-722 is a recirculating fluidized bed reactor that utilizes microorganisms in an activated carbon media to anaerobically convert organic material in the presence of water into methane and carbon dioxide. The bioreactor water effluent is discharged to the local publicly owned treatment works (POTW). The exhaust gas from the bioreactor is primarily methane and carbon dioxide with lesser amounts of hydrocarbons.

The methane gas generated from microorganism activity is vented to an enclosed flare.

The flow chart below illustrates the wastewater treatment system.

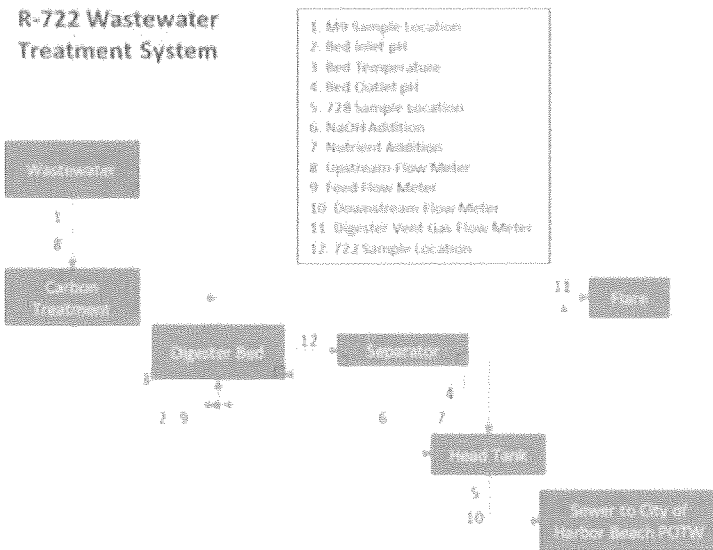

2.1.3 Wastewater Treatment Unit

As summarized in Section 6, SRN B4942 wastewater from the PAI process unit is directed to a closed anaerobic biological treatment process (Bioreactor R-722) to reduce the chemical oxygen demand (COD) and remove methanol.

2.2 FLUE GAS SAMPLING LOCATIONS

Information regarding the sampling locations is presented in Table 2-1.

**TABLE 2-1
 SAMPLING LOCATIONS**

Sampling Location	Stack Inside Diameter (in.)	Distance from Nearest Disturbance		Number of Traverse Points
		Downstream EPA "B" (in./dia.)	Upstream EPA "A" (in./dia.)	
TTU 850 Inlet	42	70/1.6	24/0.6	Flowrate: 16 (8/port); Gaseous: 3
TTU 855 Inlet	42	70/1.6	48/1.1	Flowrate: 16 (8/port); Gaseous: 3
TTU 860,865 Inlet	42	88/2.1	48/1.1	Flowrate: 16 (8/port); Gaseous: 3
TTU 870 Inlet	42	120/2.9	41/1.0	Flowrate: 16 (8/port); Gaseous: 3
TTUs 850, 855, 860, and 865 Exhaust	48	300/6.3	144/3	Isokinetic: 16 (8/port); Gaseous: 3
TTU 870 Exhaust	36 x 78	162/3.3	144/2.9	Isokinetic: 24 (6/port); Gaseous: 3

2.2.2 Flare Samples

Flare vent gas samples were collected in the headspace of the bioreactor and are exhausted to a non-assisted enclosed flare. Prior to the flare, the bioreactor vent gas is combined with a nitrogen purge stream and sent to a separator vessel for water removal. The bioreactor vent gas and nitrogen purge flow rates are measured prior to being combined using separate permanently installed mass flow meters. Bioreactor vent gas flow is measured using a thermal mass flow meter and automated control valve. The nitrogen flow is maintained using a mass flow meter.

2.2.3 Wastewater Treatment Unit

Samples were collected to again confirm ongoing compliance with fraction removal requirements. Refer to the R-722 Wastewater Treatment System flowchart above. Samples were collected from point 1 (M9 tank), point 5 (V-728) and point 12 (V-722).

2.3 OPERATING CONDITIONS AND PROCESS DATA

Performance testing was accomplished during two test conditions

2.3.1 Test Condition 1

TTU, Flare, and WWTU measurements will be collected while the process unit is operating at capacity (>90% maximum capacity) which equates to the worst-case emission profile for methanol. Methanol is the only hazardous air pollutant with an emission profile of any significance. Methanol DRE% was determined on all 5 units.

VOC, Particulate Matter (PM), formaldehyde (CH₂O), ammonia (NH₃), nitrogen oxide (NO_x), and carbon monoxide (CO) concentrations were also collected.

Plant personnel are responsible for establishing capacity operations prior to sample collection and collecting all applicable unit-operating data. Data collected includes the following parameters:

Natural Gas feed rates to each burner

Production Rate

Catalyst Inlet temperatures (TTUs 850-865)

Catalyst Outlet temperatures (TTUs 850-865)

Firebox Temperature (TTUs 870)

2.3.1 Test Condition 2

In August 2019, the site introduced vent gas to TTU-870. This TTU is a regenerative thermal oxidizer. The associated ceramic media is characterized by a cold and hot face. The cold face is the lower face of the ceramic media. The “cold” face reference is attributed because it is the cooler face. The hot face is at the top and sees the high combustion temperature. The first point of vent gas contact is the cold face. Aerosolized foam and solids tend to stick to the ceramic media after entering. Originally, the TTU was taken off-line every 8-weeks to conduct a burnout to mitigate solid build up. This operating discipline was not effective. In May 2021, the TTU was modified to allow for on-line bakeouts. This will allow for bakeout to occur on a more frequent basis.

Test condition 2 was accomplished during an on-line bakeout. Method 5 samples were collected at the start of the bakeout. The site recorded the date and time of the bakeout that occurred prior to test condition 2 sampling. The period is anticipated to be 2-4 weeks. The duration of time between the previous bakeout and the test condition 2 sampling will be used to establish an operating discipline frequency.

3.0 SAMPLING AND ANALYTICAL PROCEDURES

3.1 TEST METHODS

The test methods for this test program were presented previously in Table 1-1. Additional information regarding specific applications or modifications to standard procedures is presented below.

3.1 TTU TEST METHODS

The test methods for this test program were presented previously in Table 1-1. Additional information regarding specific applications or modifications to standard procedures is presented below.

3.1.1 EPA Method 1, Sample and Velocity Traverses for Stationary Sources

EPA Method 1 is used to assure that representative measurements of volumetric flow rate are obtained by dividing the cross-section of the stack or duct into equal areas, and then locating a traverse point within each of the equal areas.

The sample port and traverse point locations are detailed in Appendix A.

3.1.2 EPA Method 2, Determination of Stack Gas Velocity and Volumetric Flow Rate (Type S Pitot Tube)

EPA Method 2 is used to measure the gas velocity using an S-type pitot tube connected to a pressure measurement device, and to measure the gas temperature using a calibrated thermocouple connected to a thermocouple indicator. Typically, Type S (Stausscheibe) pitot tubes conforming to the geometric specifications in the test method are used, along with an inclined manometer. The measurements are made at traverse points specified by EPA Method 1. The molecular weight of the gas stream is determined from independent measurements of O₂, CO₂, and moisture. The stack gas volumetric flow rate is calculated using the measured average velocity head, the area of the duct at the measurement plane, the measured average temperature, the measured duct static pressure, the molecular weight of the gas stream, and the measured moisture.

The sampling apparatus is detailed in Figure 3-1.

**FIGURE 3-1
US EPA METHOD 2 SAMPLING TRAIN**

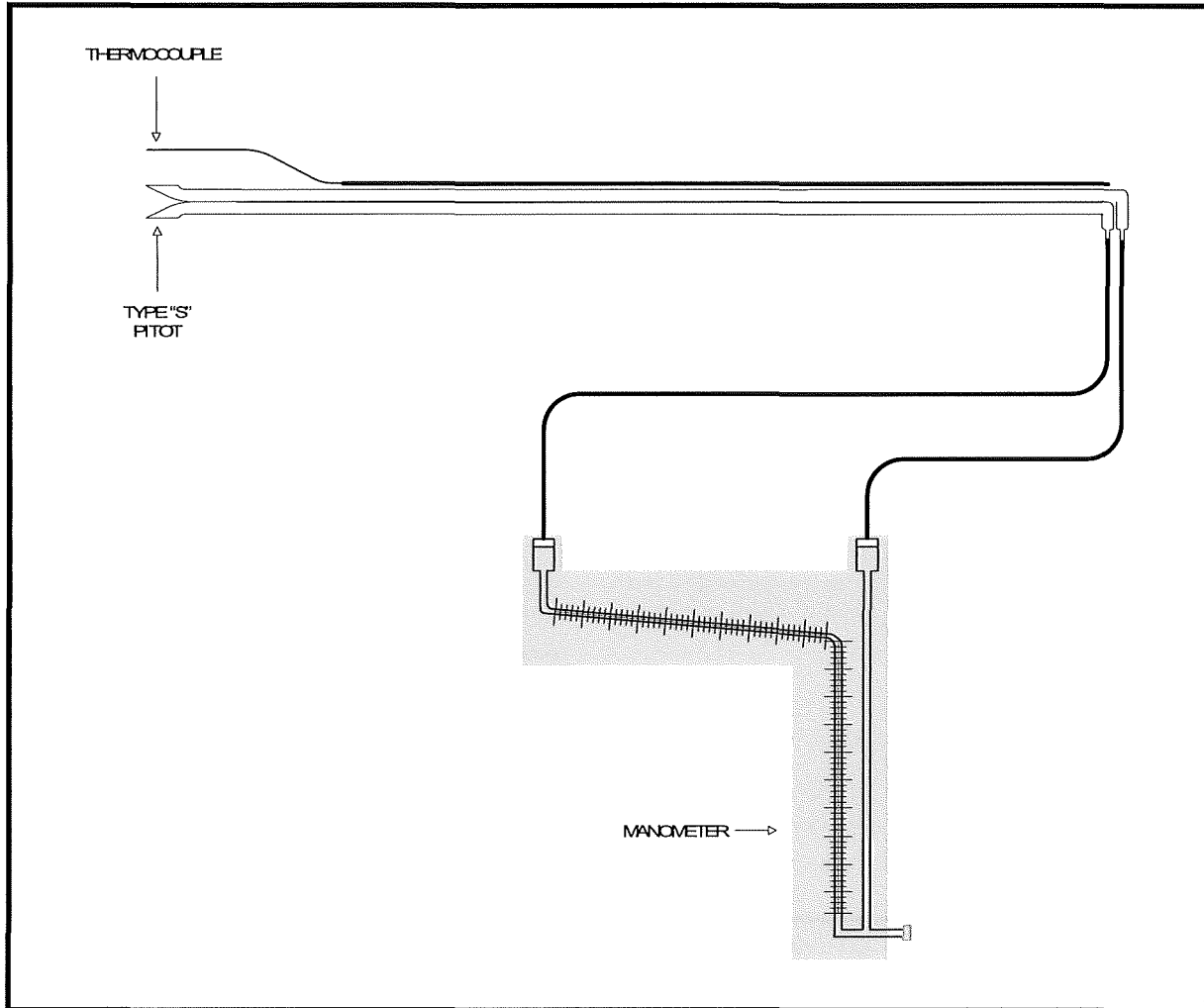

3.1.3 EPA Method 3A, Determination of Oxygen and Carbon Dioxide Concentrations in Emissions from Stationary Sources (Instrumental Analyzer Procedure)

EPA Method 3A is an instrumental test method used to measure the concentration of O₂ and CO₂ in stack gas. The effluent gas is continuously or intermittently sampled and conveyed to analyzers that measure the concentration of O₂ and CO₂. The performance requirements of the method must be met to validate data.

Pertinent information regarding the performance of the method is presented below:

- Target and/or Minimum Required Sample Duration: 60 minutes

The typical sampling system is detailed in Figure 3-2.

**FIGURE 3-2
 EPA METHODS 3A (O₂), 25A SAMPLING TRAIN**

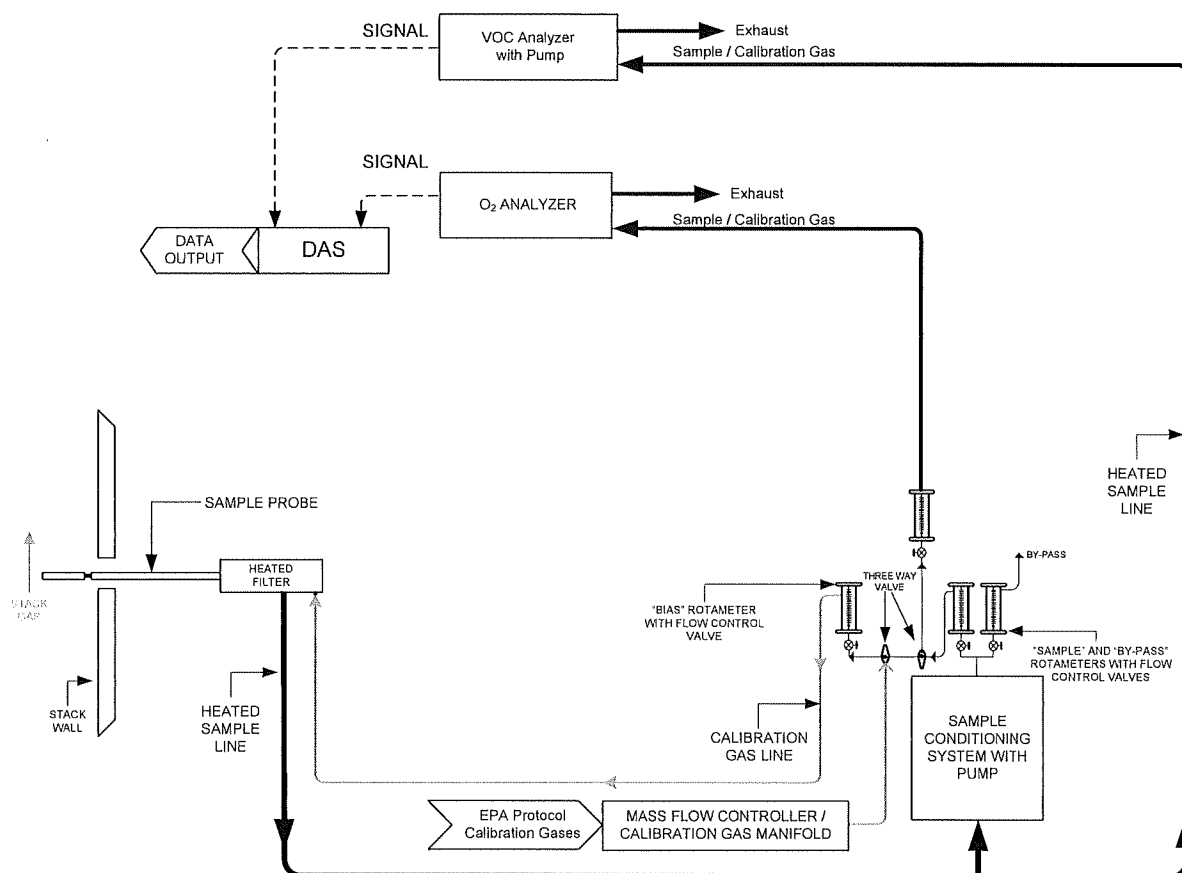

3.1.4 EPA Method 4, Determination of Moisture Content in Stack Gas

EPA Method 4 is a manual, non-isokinetic method used to measure the moisture content of gas streams. Gas is sampled at a constant sampling rate through a probe and impinger train. Moisture is removed using a series of pre-weighed impingers containing methodology-specific liquids and silica gel immersed in an ice water bath. The impingers are weighed after each run to determine the percent moisture.

Pertinent information regarding the performance of the method is presented below:

- Method Options:
 - Condensed water is measured gravimetrically
 - Moisture sampling is performed as part of the pollutant sample trains or as part of the Method 320 sample train

- Target and/or Minimum Required Sample Duration: 60 minutes
- Target and/or Minimum Required Sample Volume: 21 scf

The typical sampling system is detailed in Figures 3-3 and 3-4.

3.1.5 EPA Method 5, Determination of Particulate Matter from Stationary Sources

EPA Method 5 is a manual, isokinetic method used to measure FPM emissions. The samples are analyzed gravimetrically. This method is performed in conjunction with EPA Methods 1 through 4. The stack gas is sampled through a nozzle, probe, filter, and impinger train. FPM results are reported in emission concentration and emission rate units.

Pertinent information regarding the performance of the method is presented below:

- Method Options:
 - Stainless steel sample nozzles and glass probe liners are used
 - Condensed water is measured gravimetrically
 - Polyethylene wash bottles and sample bottles are used
- Method Exceptions:
 - A flexible probe extension may be used to connect the sample probe to the impinger box
- Target and/or Minimum Required Sample Duration: 60 minutes
- Analytical Laboratory: MAQS Detroit, Royal Oak, MI

The typical sampling system is detailed in Figure 3-3.

**FIGURE 3-3
 US EPA METHOD 5 SAMPLING TRAIN**

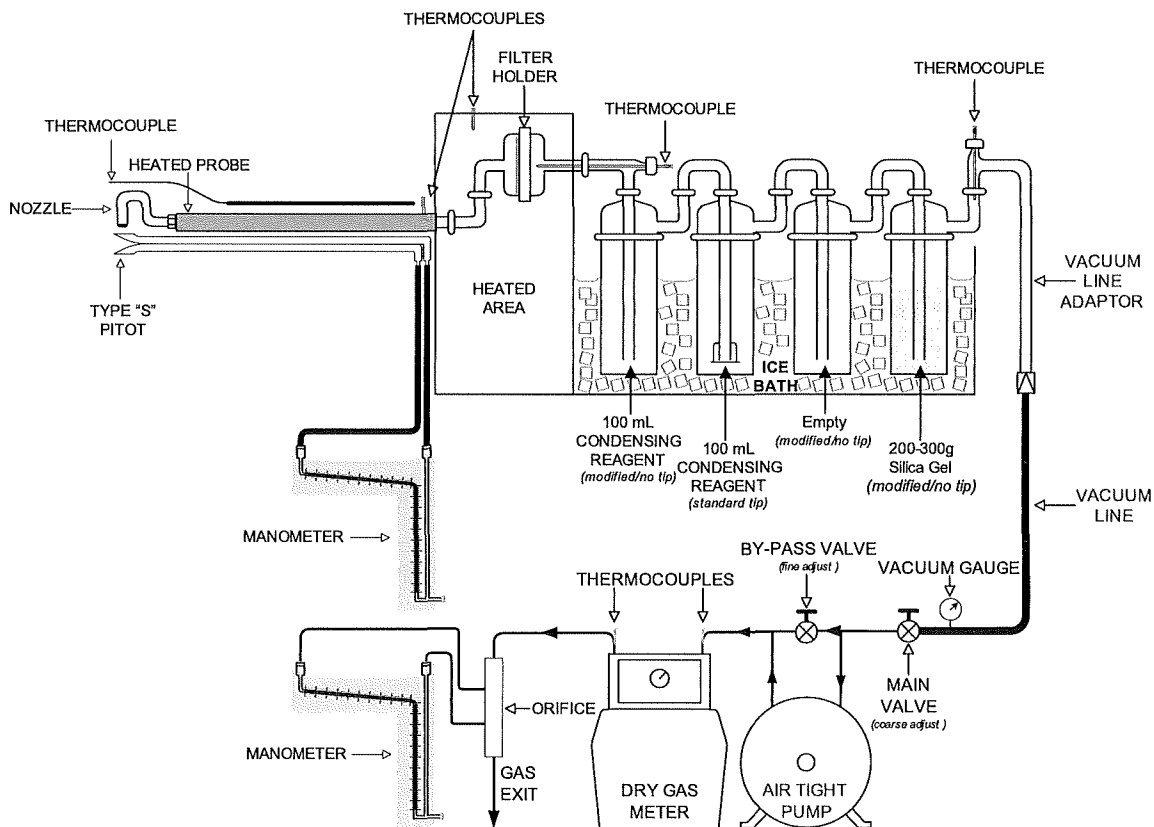

3.1.6 EPA Method 25A, Determination of Total Gaseous Organic Concentration Using a Flame Ionization Analyzer

EPA Method 25A is an instrumental test method used to measure the concentration of THC in stack gas. A gas sample is extracted from the source through a heated sample line and glass fiber filter to a flame ionization analyzer (FIA). Results are reported as volume concentration equivalents of the calibration gas or as carbon equivalents.

Pertinent information regarding the performance of the method is presented below:

- Method Options:
 - Results are reported in terms of Methane
- Target and/or Minimum Required Sample Duration: 60 minutes

The typical sampling system is detailed in Figure 3-2.

3.1.7 EPA Method 320, Measurement of Vapor Phase Organic and Inorganic Emissions by Extractive FTIR Spectroscopy

EPA Method 320 is an instrumental test method used to measure specific analyte concentrations for which EPA reference spectra have been developed or prepared. Extractive emission measurements are performed using FTIR spectroscopy. The FTIR analyzer is composed of a spectrometer and detector, a high optical throughput sampling cell, analysis software, and a quantitative spectral library. The analyzer collects high resolution spectra in the mid infrared spectral region (400 to 4,000 cm^{-1}), which are analyzed using the quantitative spectral library. This provides an accurate, highly sensitive measurement of gases and vapors.

Pertinent information regarding the performance of the method is presented below:

- Method Options:
 - The specific analyte concentrations were NO_x, CO, H₂O, formaldehyde, methanol, and Ammonia
- Target and/or Minimum Required Sample Duration: 60 minutes
- Analytical Laboratory: Montrose Mt Pleasant, Mt Pleasant, MI

The typical sampling system is detailed in Figure 3-4.

FIGURE 3-4
US EPA METHOD 320 SAMPLING TRAIN

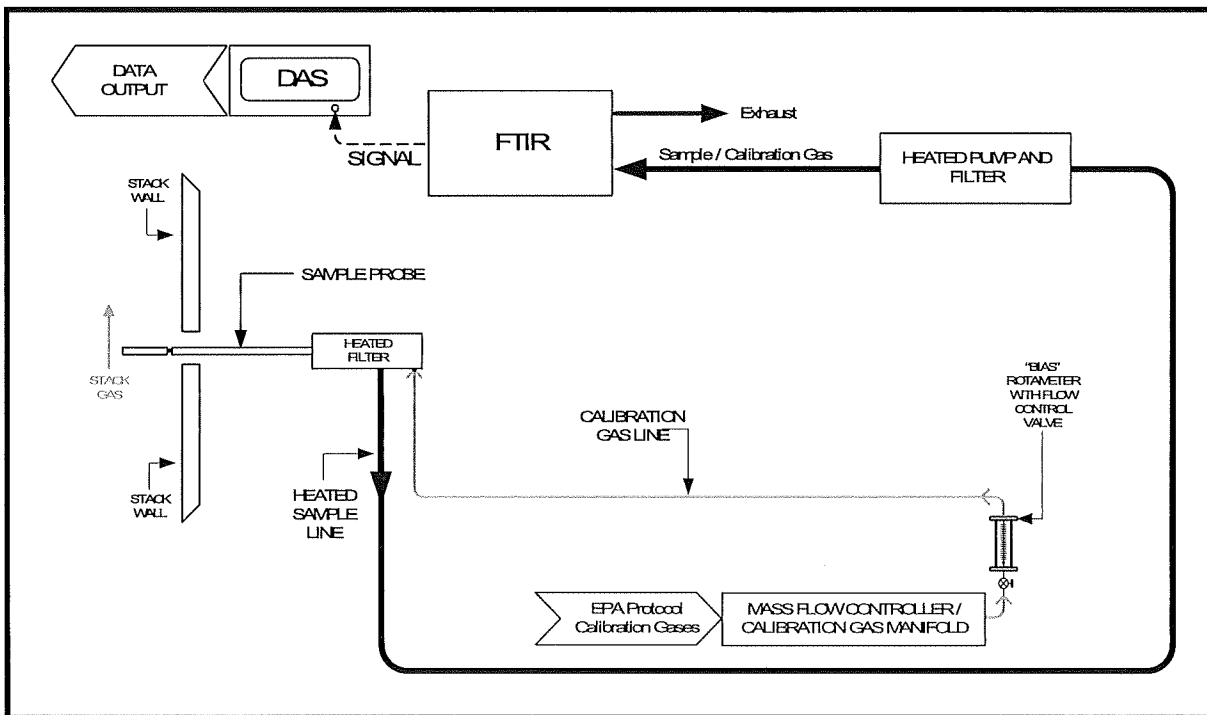

3.2 FLARE TEST METHODS

3.2.1 EPA Alt-080/073 – Inlet Vent Flow Rate

The gas velocity and volumetric flow rate are determined using the plant on-line mass flow meters as allowed by EPA Alt-080/073. The bioreactor vent gas and nitrogen purge flow-rates are measured prior to being combined using separate permanently installed mass flow meters. Bioreactor vent gas flow is measured using the process meter.

3.2.2 EPA Method 22 – Visible Emissions Observations

Method 22 was performed by an observer educated on the general procedures for determining the presence of visible emissions (no certification required). The emissions were observed over a two-hour test period. The observer is required to take a five-minute break after every twenty minutes of observations.

3.2.3 ASTM D1946-90 – TOC Sampling and Analysis

TOC sampling will be conducted on the flare inlet vent using evacuated stainless-steel summa canisters, then analyses by ASTM D1946-90 to calculate the net heating value of the gas being combusted. Three runs of approximately 1-hour duration were conducted. Samples were shipped to enthalpy analytical for analysis. The table below lists all the parameters and results during the flare performance test.

Enclosed Flare Testing Results				
Parameter	Run 1	Run 2	Run 3	Average
Bioreactor Vent Gas Flow	83 lb/hr	65 lb/hr	79 lb/hr	75 lb/hr
Flame Verification	>300°F	>300°F	>300°F	>300°F
Flare Vent Gas Net Heating Value	814 BTU/scf	806 BTU/scf	814 BTU/scf	812 BTU/scf
Visible Emissions Assessment	0 minutes	0 minutes	0 minutes	0 minutes

3.3 Wastewater Treatment Unit Test Methods

SRN B4942 wastewater from the PAI process unit is directed to a closed anaerobic biological treatment process (Bioreactor R-722) to reduce the chemical oxygen demand (COD) and remove methanol.

Bioreactor treatment efficiency sampling was initially accomplished in 2004. In October 2019, Corteva performed sampling to confirm ongoing compliance with the fraction removal requirements.

Refer to the flowchart in Section 2.1.2. Samples were collected in 40ml VOA vials at points 1 (M9 tank) and point 5 (V-728). The samples were shipped to enthalpy analytical in Durham, NC for analysis. The results below confirmed ongoing compliance with the standard.

728 R1 laboratory results for MeOH, NH₃, and Formic Acid were questionable. While the lab performed all necessary checks and QA/QC, Both MAQs and Corteva believe that there was an error associated with this sample, either during collection or custody of the sample. The full results of the testing are shown below. The following two tables show the sytem removal efficiency using the results of both the three-run average, and two-run average.

Bioreactor R-722 Wastewater Treatment Sampling and Analysis Results

Parameter	722	728	M9	722	728	M9	722	728	M9
	Run 1	Run 1	Run 1	Run 2	Run 2	Run 2	Run 3	Run 3	Run 3
	(ug)	(ug)	(ug)	(ug)	(ug)	(ug)	(ug)	(ug)	(ug)
Methanol	ND	2.27	90,138	ND	3,697	93,612	ND	3,225	88,783
m-Xylene	ND	ND	ND	ND	ND	ND	ND	ND	ND
o-Xylene	ND	ND	79	ND	ND	83.4	ND	ND	86.6
p-Xylene	ND	ND	37	ND	ND	39.6	ND	ND	39.7
1,2,4-TMB	ND	ND	545	ND	ND	591	ND	ND	628
NH ₃	ND	4,932	308	ND	237	310	ND	153	271
Formic Acid	ND	ND	2,349	ND	62.7	2,291	ND	86.9	2,192
Sulfate	538	267	1316	520	500	1,457	594	488	1,268

One (1) ug was used to calculate System Removal percentages for non-detect (ND) measurements.

Bioreactor R-722 Wastewater Treatment System Removal Results (Run 1-3)

System Removal	Avg. Inlet (ug)	Avg. Outlet (ug)	System Removal
Methanol	90,844	2,308	97.5%
m-Xylene	ND	ND	NA
o-Xylene	83	1	98.8%
p-Xylene	39	1	97.4%
1,2,4-TMB	588	1	99.8%
NH ₃	296	1,774	-498.7*
Formic Acid	2,277	57	97.5%
Sulfate	1,347	418	68.9%

Bioreactor R-722 Wastewater Treatment System Removal Results (Run 2-3)

System Removal	Avg. Inlet (ug)	Avg. Outlet (ug)	System Removal
Methanol	91,198	3,461	96.2%
m-Xylene	ND	ND	NA
o-Xylene	85	1	98.8%
p-Xylene	40	1	97.5%
1,2,4-TMB	610	1	99.8%
NH ₃	291	195	32.9%
Formic Acid	2,242	75	96.7%
Sulfate	1,363	494	63.7%

4.0 TEST DISCUSSION AND RESULTS

4.1 FIELD TEST DEVIATIONS AND EXCEPTIONS

No field deviations or exceptions from the test plan or test methods occurred during this test program. The TTU 865 run 1 sampling train post-test leak check failed. A fourth run was performed. Run 1 data is presented in this report, but is not used in any of the averages.

4.2 PRESENTATION OF RESULTS

The average results are compared to the permit limits in Table 1-2. The results of individual compliance test runs performed are presented in Tables 4-1 through 4-11. Emissions are reported in units consistent with those in the applicable regulations or requirements. Additional information is included in the appendices as presented in the Table of Contents.

Corteva Agriscience – Harbor Beach Operations
2021 Compliance Source Test Report

TABLE 4-1 TTU 850 Vapor Phase

TTU 850	Run 1 7/29/2021 1615-1715	Run 2 7/29/2021 1730-1830	Run 3 7/29/2021 1845-1945	Average
PROCESS DATA				
Fire Box Temperature (°F)	874.3	874.8	874.7	874.6
Catalyst Inlet Temperature (°F)	870.8	871.6	871.5	871.3
Catalyst Outlet Temperature (°F)	870.5	871.4	871.1	871.0
Catalyst Temperature Differential (°F)	-0.3	-0.2	-0.4	-0.3
Natural Gas Flow (MMscf/hr)	0.00995	0.01008	0.01014	0.01005
EMISSIONS DATA				
Stack Gas Flow (cf/min)	31,991	32,891	32,312	32,398
Stack Gas Flow (dscf/min)	17,227	17,888	17,603	17,527
Stack Gas Dry Molecular Weight (lb/lb-mol)	29.1	29.1	29.1	29.1
NOx (ppmv)	12.8	12.3	12.7	12.6
NOx (lb/hr)	1.6	1.6	1.6	1.6
NOx Natural Gas Emission Factor (lb/MMscf)	160.8	158.7	157.8	159.1
CO (ppmv)	1.4	1.1	1.2	1.2
CO (lb/hr)	0.1	0.1	0.1	0.1
CO Natural Gas Emission Factor (lb/MMscf)	10.1	9.9	9.9	9.9
VOC (ppmv)	9.5	10.6	11.0	10.4
VOC (lb/hr)	0.4	0.5	0.5	0.5
CH2O (ppmv)	22.8	22.6	23.5	23.0
CH2O (lb/hr)	2.0	2.0	2.0	2.0
CH2O Natural Gas Emission Factor (lb/scf)	2.01E-04	1.98E-04	1.97E-04	1.99E-04
NH3 (ppmv)	0.1	ND	ND	0.1
NH3 (lb/hr)	0.005	ND	ND	0.005
NH3 Natural Gas Emission Factor (lb/scf)	5.03E-07	ND	ND	1.68E-07
MeOH (ppmv)	13.6	13.7	14.5	13.9
MeOH (lb/hr)	1.3	1.3	1.3	1.3
MeOH Natural Gas Emission Factor (lb/scf)	1.31E-04	1.29E-04	1.28E-04	1.29E-04
Inlet Flow (scf/min)	17,657	17,962	16,084	17,235
Inlet MeOH (ppmv)	291.6	296.2	302.3	296.7
Inlet MeOH (lb/hr)	25.7	26.5	24.2	25.5
Inlet MeOH Natural Gas Emission Factor (lb/scf)	2.58E-03	2.63E-03	2.39E-03	2.53E-03
MeOH DRE (%)	95.1	95.1	94.4	94.9

Corteva Agriscience – Harbor Beach Operations
 2021 Compliance Source Test Report

Table 4-2 TTU 850 PM

TTU 850	Run 1 7/29/2021 915-1021	Run 2 7/29/2021 1110-1215	Run 3 7/29/2021 1255-1400	Average
PROCESS DATA				
Fire Box Temperature (°F)	875.0	875.2	875.3	875.2
Catalyst Inlet Temperature (°F)	871.3	871.7	871.4	871.5
Catalyst Outlet Temperature (°F)	871.0	870.9	871.3	871.1
Catalyst Temperature Differential (°F)	-0.3	-0.7	-0.1	-0.4
Natural Gas Flow (MMscf/hr)	0.00957	0.01005	0.00991	0.00984
EMISSIONS DATA				
Stack Gas Flow (cf/min)	31,991	32,891	32,312	32,398
Stack Gas Flow (dscf/min)	17,227	17,888	17,603	17,527
Stack Gas Dry Molecular Weight (lb/lb-mol)	29.1	29.1	29.1	29.1
PM (grains/dscf)	0.0006	0.0006	0.0005	0.0006
PM (lb/hr)	0.087	0.098	0.078	0.088
PM (lb/lb x 10 ³ stack gas)	0.001	0.001	0.001	0.001
PM Natural Gas Emission Factor (lb/scf)	9.09E-06	9.75E-06	7.87E-06	8.90E-06

Corteva Agriscience – Harbor Beach Operations
2021 Compliance Source Test Report

TABLE 4-3 TTU 855 Vapor Phase

TTU 855	Run 1 7/29/2021 920-1020	Run 2 7/29/2021 1112-1212	Run 3 7/29/2021 1254-1354	Average
PROCESS DATA				
Fire Box Temperature (°F)	655.8	656.2	655.9	656.0
Catalyst Inlet Temperature (°F)	654.8	655.0	654.9	654.9
Catalyst Outlet Temperature (°F)	656.8	656.9	656.3	656.6
Catalyst Temperature Differential (°F)	2.0	1.9	1.4	1.8
Natural Gas Flow (MMscf/hr)	0.01021	0.01031	0.01034	0.01028
EMISSIONS DATA				
Stack Gas Flow (cf/min)	37,839	39,634	39,251	38,908
Stack Gas Flow (dscf/min)	22,170	23,098	23,267	22,845
Stack Gas Dry Molecular Weight (lb/lb-mol)	29.1	29.1	29.1	29.1
NOx (ppmv)	10.9	10.8	10.3	10.7
NOx (lb/hr)	1.7	1.8	1.7	1.7
NOx Natural Gas Emission Factor (lb/MMscf)	166.5	174.6	164.4	168.5
CO (ppmv)	0.5	0.5	0.5	0.5
CO (lb/hr)	0.1	0.1	0.1	0.1
CO Natural Gas Emission Factor (lb/MMscf)	9.8	9.7	9.7	9.7
VOC (ppmv)	8.8	8.9	8.5	8.8
VOC (lb/hr)	0.5	0.5	0.5	0.5
CH2O(ppmv)	6.9	7.2	6.8	7.0
CH2O (lb/hr)	0.8	0.8	0.8	0.8
CH2O Natural Gas Emission Factor (lb/scf)	7.84E-05	7.76E-05	7.74E-05	7.78E-05
NH3 (ppmv)	0.3	0.2	0.1	0.2
NH3 (lb/hr)	0.02	.01	0.01	0.01
NH3 Natural Gas Emission Factor (lb/scf)	1.96E-06	9.7E-07	9.67E-07	1.30E-06
MeOH (ppmv)	3.8	4.0	3.8	3.9
MeOH (lb/hr)	0.4	0.5	0.5	0.5
MeOH Natural Gas Emission Factor (lb/scf)	3.92E-05	4.85E-05	4.84E-05	4.53E-05
Inlet Flow (scf/min)	23,423	23,148	23,308	23,293
Inlet MeOH (ppmv)	332.0	328.2	325.2	328.5
Inlet MeOH (lb/hr)	38.8	37.9	37.8	38.2
Inlet MeOH Natural Gas Emission Factor (lb/dscf)	3.80E-03	3.68E-03	3.66E-03	3.71E-03
MeOH DRE (%)	98.9	98.7	98.8	98.8

RECEIVED

OCT 04 2021

Corteva Agriscience – Harbor Beach Operations
2021 Compliance Source Test Report

AIR QUALITY DIVISION

Table 4-4 TTU 855 PM

TTU 855	Run 1 7/29/2021 934-1045	Run 2 7/29/2021 1112-1221	Run 3 7/29/2021 1254-1402	Average
PROCESS DATA				
Fire Box Temperature (°F)	655.9	656.2	655.9	656.0
Catalyst Inlet Temperature (°F)	655.0	655.1	654.9	655.0
Catalyst Outlet Temperature (°F)	656.7	656.8	656.4	656.6
Catalyst Temperature Differential (°F)	1.8	1.8	1.4	1.7
Natural Gas Flow (MMscf/hr)	0.01028	0.01031	0.01034	0.01031
EMISSIONS DATA				
Stack Gas Flow (cf/min)	37,839	39,634	39,251	38,908
Stack Gas Flow (dscf/min)	22,170	23,098	23,267	22,845
Stack Gas Dry Molecular Weight (lb/lb-mol)	29.1	29.1	29.1	29.1
PM (grains/dscf)	0.0001	0.0001	0.0008	0.0003
PM (lb/hr)	0.013	0.022	0.151	0.062
PM (lb/lb x 10 ³ stack gas)	0.0001	0.0001	0.0008	0.0003
PM Natural Gas Emission Factor (lb/scf)	1.26E-06	2.13E-06	1.46E-05	6.00E-06

Corteva Agriscience – Harbor Beach Operations
2021 Compliance Source Test Report

TABLE 4-5 TTU 860 Vapor Phase

TTU 860	Run 1 7/28/2021 1555-1655	Run 2 7/28/2021 1710-1810	Run 3 7/28/2021 1825-1925	Average
PROCESS DATA				
Fire Box Temperature (°F)	656.5	657.3	656.6	656.8
Catalyst Inlet Temperature (°F)	644.3	644.0	643.1	643.8
Catalyst Outlet Temperature (°F)	650.5	650.2	649.4	650.0
Catalyst Temperature Differential (°F)	6.3	6.3	6.4	6.3
Natural Gas Flow (MMscf/hr)	0.00528	0.00533	0.00534	0.00532
EMISSIONS DATA				
Stack Gas Flow (cf/min)	30,842	30,627	30,657	30,709
Stack Gas Flow (dscf/min)	19,572	19,158	19,464	19,398
Stack Gas Dry Molecular Weight (lb/lb-mol)	29.1	29.1	29.1	29.1
NOx (ppmv)	12.8	12.8	12.9	12.8
NOx (lb/hr)	1.8	1.8	1.8	1.8
NOx Natural Gas Emission Factor (lb/MMscf)	340.9	337.7	337.1	338.6
CO (ppmv)	0.5	0.5	0.5	0.5
CO (lb/hr)	0.05	0.04	0.04	0.04
CO Natural Gas Emission Factor (lb/MMscf)	9.5	7.5	7.5	8.2
VOC (ppmv)	3.6	3.5	3.3	3.5
VOC (lb/hr)	0.1	0.2	0.1	0.1
CH2O (ppmv)	1.6	1.8	1.8	1.7
CH2O (lb/hr)	0.2	0.2	0.2	0.2
CH2O Natural Gas Emission Factor (lb/scf)	3.79E-05	3.75E-05	3.75E-05	3.76E-05
NH3 (ppmv)	0.3	0.2	0.1	0.2
NH3 (lb/hr)	0.02	0.01	0.01	0.01
NH3 Natural Gas Emission Factor (lb/scf)	3.79E-06	1.88E-06	1.87E-06	2.51E-06
MeOH (ppmv)	1.3	1.2	1.2	1.2
MeOH (lb/hr)	0.1	0.1	0.1	0.1
MeOH Natural Gas Emission Factor (lb/scf)	1.89E-05	1.88E-05	1.87E-05	1.88E-05
Inlet Flow (scf/min)	18,683	19,159	18,922	18,921
Inlet MeOH (ppmv)	374.3	378.0	378.3	376.9
Inlet MeOH (lb/hr)	34.9	36.1	35.7	35.6
Inlet MeOH Natural Gas Emission Factor (lb/dscf)	6.61E-03	6.77E-03	6.69E-03	6.69E-03
MeOH DRE (%)	99.6	99.7	99.7	99.6

Corteva Agriscience – Harbor Beach Operations
 2021 Compliance Source Test Report

Table 4-6 TTU 860 PM

TTU 860	Run 1 7/28/2021 905-1012	Run 2 7/28/2021 1045-1152	Run 3 7/28/2021 1218-1327	Average
PROCESS DATA				
Fire Box Temperature (°F)	662.5	659.0	657.0	659.5
Catalyst Inlet Temperature (°F)	649.7	646.6	644.1	646.8
Catalyst Outlet Temperature (°F)	658.1	654.3	649.7	654.0
Catalyst Temperature Differential (°F)	8.4	7.7	5.7	7.3
Natural Gas Flow (MMscf/hr)	0.00508	0.00508	0.00525	0.00513
EMISSIONS DATA				
Stack Gas Flow (cf/min)	30,842	30,627	30,657	30,709
Stack Gas Flow (dscf/min)	19,572	19,158	19,464	19,398
Stack Gas Dry Molecular Weight (lb/lb-mol)	29.1	29.1	29.1	29.1
PM (grains/dscf)	0.0006	0.0007	0.0004	0.0006
PM (lb/hr)	0.100	0.109	0.068	0.093
PM (lb/lb x 10 ³ stack gas)	0.001	0.001	0.001	0.001
PM Natural Gas Emission Factor (lb/scf)	1.97E-05	2.15E-05	1.30E-05	1.80E-05

Corteva Agriscience – Harbor Beach Operations
2021 Compliance Source Test Report

TABLE 4-7 TTU 865 Vapor Phase

TTU 865	Run 1 7/27/2021 1025-1132	Run 2 7/27/2021 1205-1310	Run 3 7/27/2021 1335-1439	Average
PROCESS DATA				
Fire Box Temperature (°F)	654.8	656.2	655.1	655.7
Catalyst Inlet Temperature (°F)	655.1	655.3	654.6	655.0
Catalyst Outlet Temperature (°F)	670.4	661.6	657.2	663.0
Catalyst Temperature Differential (°F)	15.3	6.3	2.6	8.1
Natural Gas Flow (MMscf/hr)	0.00598	0.00631	0.00645	0.00624
EMISSIONS DATA				
Stack Gas Flow (cf/min)	32,927	32,679	33,587	33,064
Stack Gas Flow (dscf/min)	19,916	19,703	20,194	19,938
Stack Gas Dry Molecular Weight (lb/lb-mol)	29.1	29.1	29.1	29.1
NOx (ppmv)	23.8	21.0	18.1	21.0
NOx (lb/hr)	3.4	3.0	2.6	3.0
NOx Natural Gas Emission Factor (lb/MMscf)	301.0	285.3	279.1	288.4
CO (ppmv)	1.7	1.1	2.4	1.7
CO (lb/hr)	0.1	0.1	0.2	0.2
CO Natural Gas Emission Factor (lb/MMscf)	16.7	15.8	31.0	21.2
VOC (ppmv)	8.5	7.5	7.2	7.7
VOC (lb/hr)	0.4	0.4	0.4	0.4
CH2O (ppmv)	2.7	3.1	3.5	3.1
CH2O (lb/hr)	0.3	0.3	0.3	0.3
CH2O Natural Gas Emission Factor (lb/scf)	5.02E-05	4.75E-05	4.65E-05	4.81E-05
NH3 (ppmv)	0.3	0.2	0.1	0.2
NH3 (lb/hr)	0.02	0.01	0.01	0.01
NH3 Natural Gas Emission Factor (lb/scf)	3.34E-06	1.58E-06	1.55E-06	2.16E-06
MeOH (ppmv)	2.6	2.8	3.0	2.8
MeOH (lb/hr)	0.3	0.3	0.3	0.3
MeOH Natural Gas Emission Factor (lb/scf)	5.02E-05	4.75E-05	4.65E-05	4.81E-05
Inlet Flow (scf/min)	19,334	19,345	20,879	19,853
Inlet MeOH (ppmv)	302.1	299.7	289.0	296.9
Inlet MeOH (lb/hr)	29.1	28.9	30.1	29.4
Inlet MeOH Natural Gas Emission Factor (lb/dscf)	4.87E-03	4.58E-03	4.67E-03	4.70E-03
MeOH DRE (%)	99.1	99.0	98.9	99.0

Corteva Agriscience – Harbor Beach Operations
2021 Compliance Source Test Report

TABLE 4-8 TTU 865 PM

TTU 865	Run 1 7/27/2021 1025-1132	Run 2 7/27/2021 1205-1310	Run 3 7/27/2021 1335-1439	Run 4 7/27/2021 1507-1611	Average
PROCESS DATA					
Fire Box Temperature (°F)	655.8	656.2	655.1	656.1	655.8
Catalyst Inlet Temperature (°F)	655.1	655.3	654.6	655.1	655.0
Catalyst Outlet Temperature (°F)	670.4	661.6	657.2	657.7	663.0
Catalyst Temperature Differential (°F)	15.3	6.3	2.6	2.6	6.7
Natural Gas Flow (MMscf/hr)	0.00598	0.00631	0.00645	0.00658	0.00624
EMISSIONS DATA					
Stack Gas Flow (cf/min)	32,927	32,679	33,587	34,052	33,311.25
Stack Gas Flow (dscf/min)	19,916	19,703	20,194	20,610	20,106
Stack Gas Dry Molecular Weight (lb/lb-mol)	29.1	29.1	29.1	29.1	29.1
PM (grains/dscf)	NA	0.0020	0.0010	0.0010	0.001
PM (lb/hr)	NA	0.341	0.169	0.170	0.227
PM (lb/lb x 10 ³ stack gas)	NA	0.004	0.002	0.002	0.002
PM Natural Gas Emission Factor (lb/scf)	NA	5.40E-05	2.62E-05	2.58E-05	3.54E-05

Corteva Agriscience – Harbor Beach Operations
2021 Compliance Source Test Report

TABLE 4-9 TTU 870 Vapor Phase

TTU 870	Run 1 7/28/2021 845-956	Run 2 7/28/2021 1030-1137	Run 3 7/28/2021 1210-1320	Average
PROCESS DATA				
Fire Box Temperature (°F)	1500.8	1499.8	1499.7	1500.1
Natural Gas Flow (MMscf/Hr)	0.00353	0.00363	0.00374	0.00363
EMISSIONS DATA				
Stack Gas Flow (cf/min)	46,635	47,088	48,627	47,450
Stack Gas Flow (dscf/min)	34,713	35,346	36,732	35,597
Stack Gas Dry Molecular Weight (lb/lb-mol)	28.9	28.9	28.9	28.9
NOx				
NOx (ppmv)	9.2	7.2	6.5	7.6
NOx (lb/hr)	2.3	1.8	1.7	1.9
NOx Natural Gas Emission Factor (lb/MMscf)	651.6	495.9	454.5	534.0
CO				
CO (ppmv)	71.5	66.0	63.9	67.1
CO (lb/hr)	10.8	10.1	10.2	10.4
CO Natural Gas Emission Factor (lb/MMscf)	3059.5	2782.4	2727.3	2856.4
VOC				
VOC (ppmv)	7.7	6.8	6.2	6.9
VOC (lb/hr)	0.7	0.6	0.6	0.6
CH2O				
CH2O (ppmv)	2.2	2.3	2.4	2.3
CH2O (lb/hr)	0.4	0.4	0.4	0.4
CH2O Natural Gas Emission Factor (lb/scf)	1.13E-04	1.10E-04	1.07E-04	1.10E-04
NH3				
NH3 (ppmv)	4.4	2.9	2.5	3.3
NH3 (lb/hr)	0.43	0.28	0.25	0.32
NH3 Natural Gas Emission Factor (lb/scf)	1.22E-04	7.71E-05	6.68E-05	8.86E-05
MeOH				
MeOH (ppmv)	9.5	9.3	9.5	9.4
MeOH (lb/hr)	1.7	1.7	1.8	1.8
MeOH Natural Gas Emission Factor (lb/scf)	4.82E-04	4.68E-04	4.81E-04	4.77E-04
Inlet MeOH				
Inlet Flow (scf/min)	35,926	34,724	37,031	35,894
Inlet MeOH (ppmv)	220.5	203.9	201.5	208.6
Inlet MeOH (lb/hr)	39.5	35.3	37.2	37.3
Inlet MeOH Natural Gas Emission Factor (lb/dscf)	1.12E-02	9.72E-03	9.95E-03	1.03E-02
MeOH DRE (%)				
MeOH DRE (%)	95.6	95.1	95.1	95.3

TABLE 4-10 TTU 870 PM

TTU 870	Run 1 7/28/2021 845-952	Run 2 7/28/2021 1026-1132	Run 3 7/28/2021 12001-1339	Average
PROCESS DATA				
Fire Box Temperature (°F)	1500.8	1499.8	1499.7	1500.1
Natural Gas Flow (MMscf/Hr)	0.00353	0.00363	0.00374	0.00363
EMISSIONS DATA				
Stack Gas Flow (cf/min)	46,635	47,088	48,627	47,450
Stack Gas Flow (dscf/min)	34,713	35,346	36,732	35,597
Stack Gas Dry Molecular Weight (lb/lb-mol)	28.9	28.9	28.9	28.9
PM (grains/dscf)	0.0018	0.0014	0.0014	0.0015
PM (lb/hr)	0.523	0.427	0.451	0.467
PM (lb/lb x 10 ³ stack gas)	0.003	0.003	0.003	0.003
PM Natural Gas Emission Factor (lb/scf)	1.48E-04	1.18E-04	1.21E-04	1.29E-04

TABLE 4-11 TTU 870 PM Condition 2

TTU 850	Run 1 7/27/2021 845-952	Run 2 7/27/2021 1026-1132	Run 3 7/27/2021 1201-1339	Average
PROCESS DATA				
Fire Box Temperature (°F)	1550.2	1555.1	1550.8	1552.0
Natural Gas Flow (MMscf/Hr)	0.00188	0.00166	0.00176	0.00177
EMISSIONS DATA				
Stack Gas Flow (cf/min)	29,570	26,714	26,356	27,547
Stack Gas Flow (dscf/min)	22,895	20,300	20,721	22,380
Stack Gas Dry Molecular Weight (lb/lb-mol)	28.9	28.9	28.9	28.9
PM (grains/dscf)	0.0044	0.0022	0.0016	0.0027
PM (lb/hr)	0.866	0.389	0.278	0.511
PM (lb/lb x 10 ³ stack gas)	0.008	0.004	0.003	0.005
PM Natural Gas Emission Factor (lb/scf)	4.61E-04	2.34E-04	1.58E-04	2.84E-04

5.0 INTERNAL QA/QC ACTIVITIES

5.1 QA/QC AUDITS

The meter boxes and sampling trains used during sampling performed within the requirements of their respective methods. All post-test leak checks, minimum metered volumes, minimum sample durations, and percent isokinetics met the applicable QA/QC criteria, except where noted in Section 5.2.

EPA Method 3A calibration audits were all within the measurement system performance specifications for the calibration drift checks, system calibration bias checks, and calibration error checks.

EPA Method 25A FIA calibration audits were within the measurement system performance specifications for the calibration drift checks and calibration error checks.

An EPA Method 205 field evaluation of the calibration gas dilution system was conducted. The dilution accuracy and precision QA specifications were met.

EPA Method 5 analytical QA/QC results are included in the laboratory report. The method QA/QC criteria were met. An EPA Method 5 reagent blank was analyzed. The maximum allowable amount that can be subtracted is 0.001% of the weight of the acetone blank. The blank did not exceed the maximum residue allowed.

The EPA Method 320 performance parameters measured included signal to noise tests, noise equivalent absorbance (NEA), detector linearity, background spectra, potential interferences, and cell and system leakage. Quality assurance procedures included baseline measurement with ultra-high purity nitrogen, measurement of a calibration transfer standard (~100 ppm ethylene), direct analyte calibration measurements, and measurements to determine baseline shift. SF₆ was also used as a tracer gas in the calibration gases to evaluate dilution ratios and verify the sample delivery system integrity. A dynamic matrix spike was performed using SF₆ as a tracer gas. The method QA/QC criteria were met.

5.2 QA/QC DISCUSSION

All QA/QC criteria were met during this test program.

5.3 QUALITY STATEMENT

Montrose is qualified to conduct this test program and has established a quality management system that led to accreditation with ASTM Standard D7036-04 (Standard Practice for Competence of Air Emission Testing Bodies). Montrose participates in annual functional assessments for conformance with D7036-04 which are conducted by the American Association for Laboratory Accreditation (A2LA). All testing performed by Montrose is supervised on site by at least one Qualified Individual (QI) as defined in D7036-04 Section 8.3.2. Data quality objectives for estimating measurement uncertainty within the documented limits in the test methods are met by using approved test protocols for each project as defined in D7036-04 Sections 7.2.1 and 12.10. Additional quality assurance information is included in the report appendices. The content of this report is modeled after the EPA Emission Measurement Center Guideline Document (GD-043).

APPENDIX A FIELD DATA



MONTROSE

AIR QUALITY SERVICES

diameter = 42

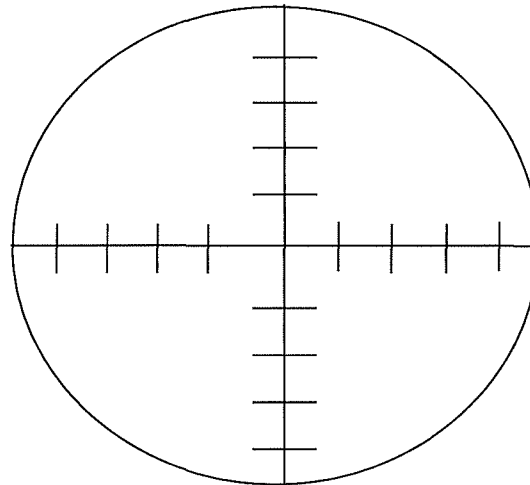
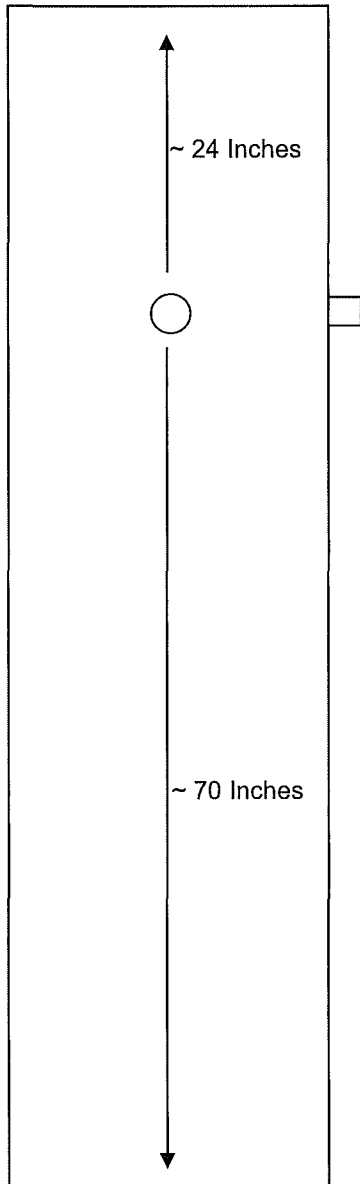

Not to Scale

Points	Distance "
1	1.3
2	4.4
3	8.1
4	13.6
5	28.4
6	33.9
7	37.6
8	40.7

Site:
Corteva Agriscience LLC
Harbor Beach Operations
TTU 850 Inlet

**Montrose Air Quality Services,
LLC**
4949 Fernlee
Royal Oak, Michigan

diameter = 42

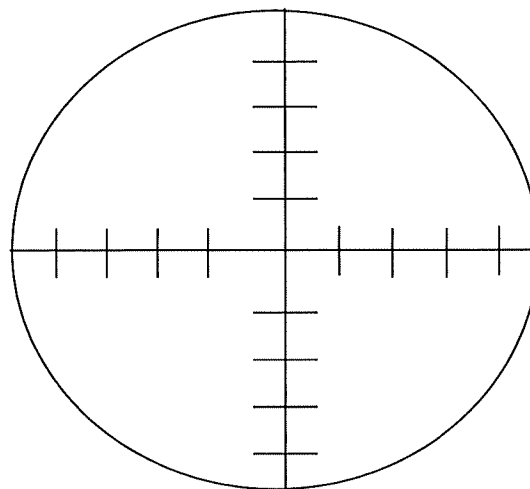
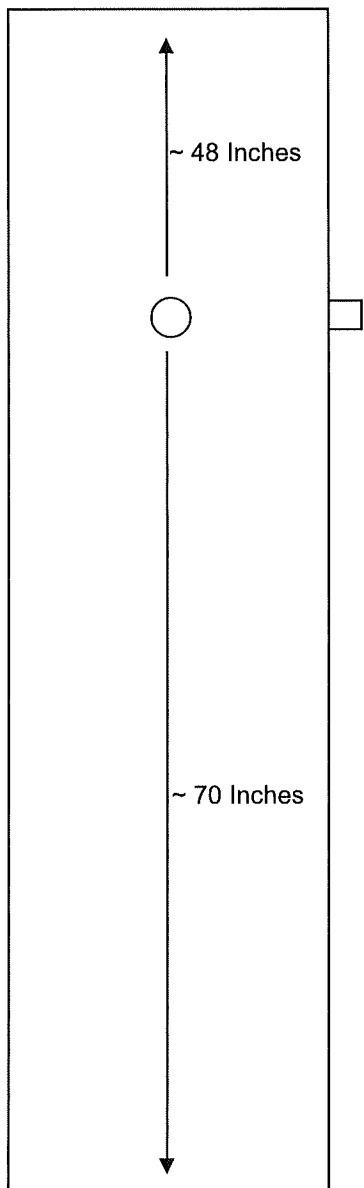

Not to Scale

Points	Distance "
1	1.3
2	4.4
3	8.1
4	13.6
5	28.4
6	33.9
7	37.6
8	40.7

Site:
Corteva Agriscience LLC
Harbor Beach Operations
TTU 855 Inlet

Montrose Air Quality Services, LLC
4949 Fernlee
Royal Oak, Michigan

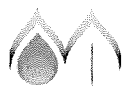

MONTROSE

AIR QUALITY SERVICES

diameter = 42

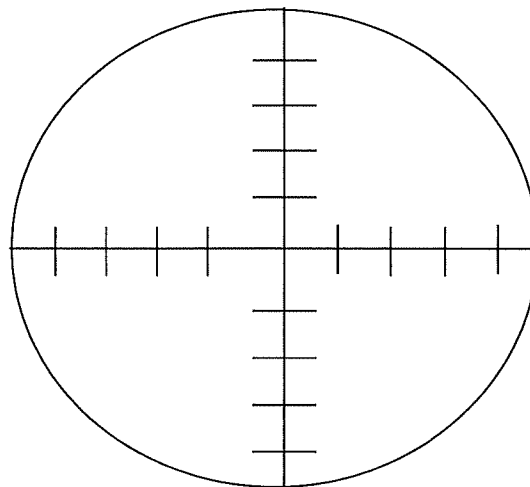
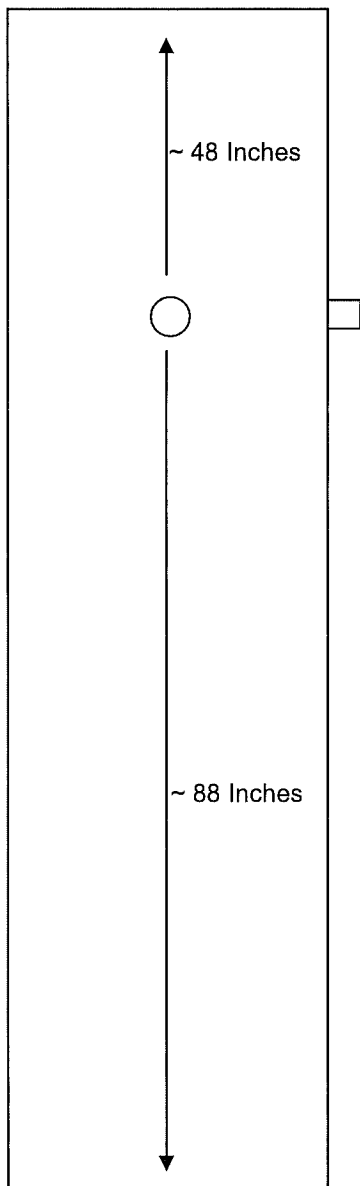

Not to Scale

Points	Distance "
1	1.3
2	4.4
3	8.1
4	13.6
5	28.4
6	33.9
7	37.6
8	40.7

Site:
Corteva Agriscience LLC
Harbor Beach Operations
TTU 860, TTU 865 Inlet

**Montrose Air Quality Services,
LLC**
4949 Fernlee
Royal Oak, Michigan



MONTROSE

AIR QUALITY SERVICES

diameter = 42

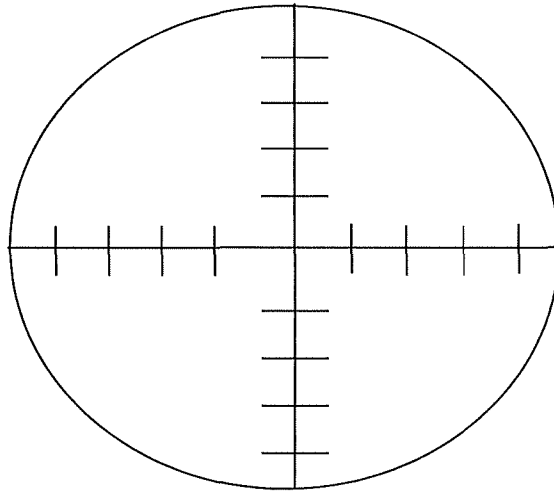
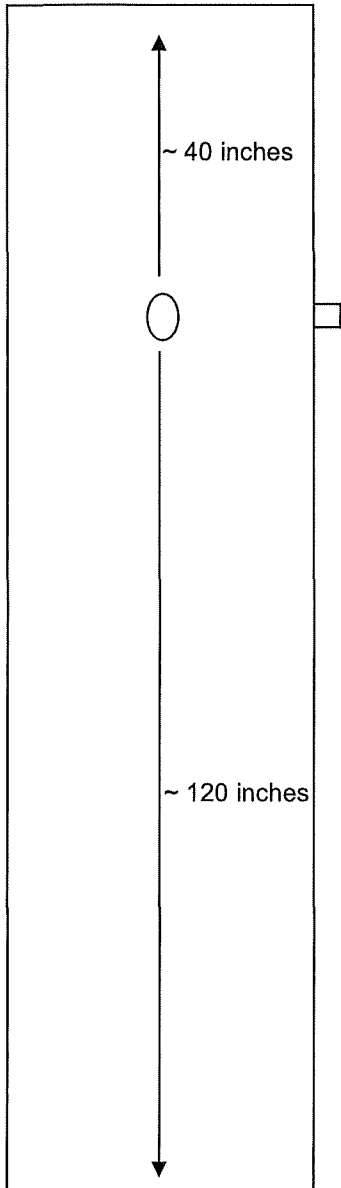

Not to Scale

Points	Distance "
1	1.4
2	4.5
3	8.2
4	13.7
5	28.8
6	34.3
7	38.0
8	41.1

Site:

Corteva Agriscience LLC
Harbor Beach Operations
TTU 870 Inlet

Montrose Air Quality Services,

LLC
4949 Fernlee
Royal Oak, Michigan

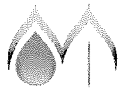

diameter = 48

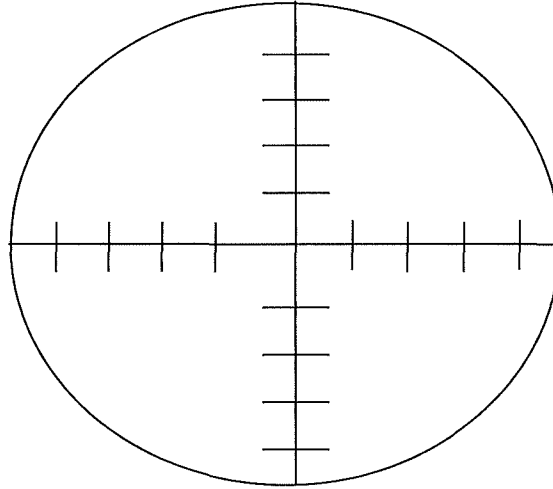
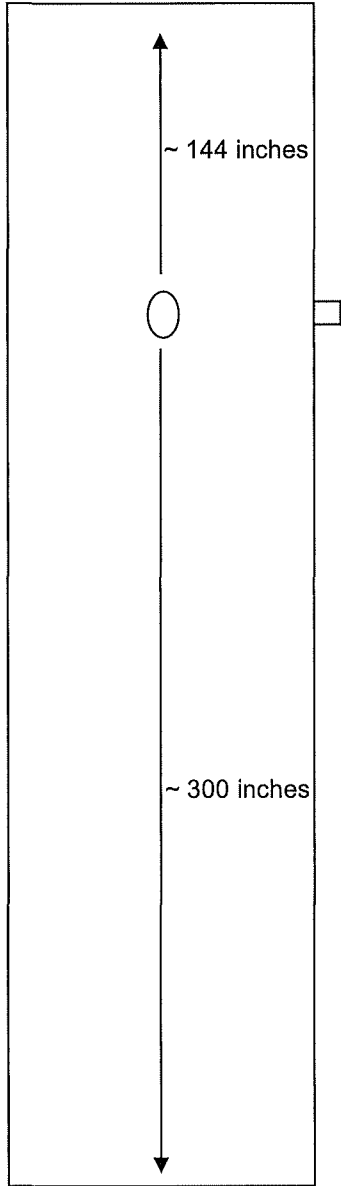

Not to Scale

Points	Distance "
1	1.5
2	5.0
3	9.3
4	15.5
5	32.5
6	38.7
7	43.0
8	46.5

Site:
Corteva Agriscience LLC
Harbor Beach Operations
TTU 850, 855, 860 and 865 Exhaust Stacks

**Montrose Air Quality Services,
LLC**
4949 Fernlee
Royal Oak, Michigan



Stack Dimensions: 36 x 78

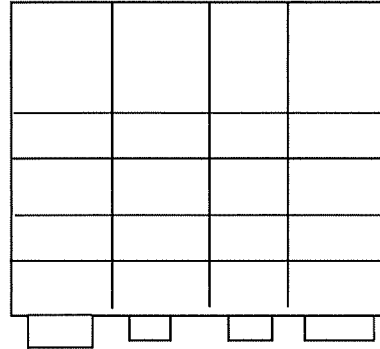
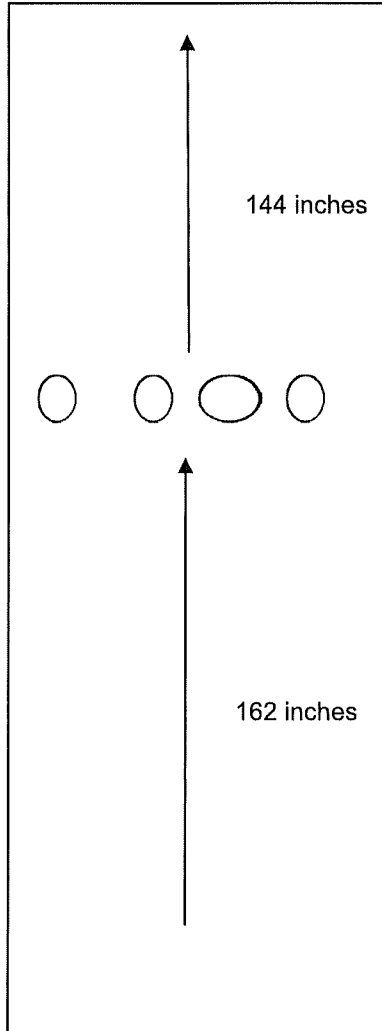

Not to Scale

Points	Distance "
1	4.5
2	9.0
3	15.0
4	21.0
5	27.0
6	33.0

Site:

Corteva Agriscience LLC
Harbor Beach Operations
TTU 870 Outlet

Montrose Air Quality Services,

LLC
4949 Fernlee
Royal Oak, Michigan

Particulate Matter Emission Rates

Company	Corteva			
Source Designation	TTU 850 Outlet			
Test Date	7/29/2021	7/29/2021	7/29/2021	
Meter/Nozzle Information				
	P-1	P-2	P-3	Average
Meter Temperature Tm (F)	72.3	76.6	80.3	76.4
Meter Pressure - Pm (in. Hg)	29.2	29.2	29.2	29.2
Measured Sample Volume (Vm)	45.1	46.6	46.1	45.9
Sample Volume (Vm-Std ft3)	44.6	45.8	45.0	45.2
Sample Volume (Vm-Std m3)	1.26	1.30	1.27	1.28
Condensate Volume (Vw-std)	3.319	2.975	2.843	3.046
Gas Density (Ps(std) lbs/ft3) (wet)	0.0733	0.0735	0.0735	0.0734
Gas Density (Ps(std) lbs/ft3) (dry)	0.0752	0.0752	0.0752	0.0752
Total weight of sampled gas (m g lbs) (wet)	3.51	3.59	3.51	3.54
Total weight of sampled gas (m g lbs) (dry)	3.36	3.45	3.38	3.40
Nozzle Size - An (sq. ft.)	0.000507	0.000507	0.000507	0.000507
Isokinetic Variation - I	100.3	99.1	98.8	99.4
Stack Data				
Average Stack Temperature - Ts (F)	425.2	424.3	424.1	424.5
Molecular Weight Stack Gas- dry (Md)	29.1	29.1	29.1	29.1
Molecular Weight Stack Gas-wet (Ms)	28.3	28.4	28.4	28.4
Stack Gas Specific Gravity (Gs)	0.979	0.982	0.982	0.981
Percent Moisture (Bws)	6.92	6.09	5.95	6.32
Water Vapor Volume (fraction)	0.0692	0.0609	0.0595	0.0632
Pressure - Ps ("Hg)	29.0	29.0	29.0	29.0
Average Stack Velocity - Vs (ft/sec)	42.5	43.6	42.9	43.0
Area of Stack (ft2)	12.6	12.6	12.6	12.6
Exhaust Gas Flowrate				
Flowrate ft ³ (Actual)	31,991	32,891	32,312	32,398
Flowrate ft ³ (Standard Wet)	18,508	19,049	18,716	18,757
Flowrate ft ³ (Standard Dry)	17,227	17,888	17,603	17,572
Flowrate m ³ (standard dry)	488	507	498	498
Total Particulate Weights (mg)				
Nozzle/Probe/Filter	1.7	1.9	1.5	1.7
Total Particulate Concentration				
lb/1000 lb (wet)	0.001	0.001	0.001	0.001
lb/1000 lb (dry)	0.001	0.001	0.001	0.001
mg/dscm (dry)	1.3	1.5	1.2	1.3
gt/dscf	0.0006	0.0006	0.0005	0.0006
Total Particulate Emission Rate				
lb/ hr	0.087	0.098	0.078	0.088

Rev. 14.0
3-20-15 BC