

**SOURCE TEST REPORT  
2021 COMPLIANCE TESTS  
THE ANDERSONS MARATHON HOLDINGS LLC  
CO<sub>2</sub> SCRUBBERS C40 AND C40A STACKS  
ALBION, MICHIGAN**

Prepared For:

**The Andersons Marathon Holdings LLC - Albion**  
26250 B Drive North  
Albion, MI 49224

Prepared By:

**Montrose Air Quality Services, LLC**  
951 Old Rand Road, Unit 106  
Wauconda, IL 60084

Document Number: **MW024AS-007941-RT-1039**  
Test Dates: **June 3 and 4, 2021**  
Submittal Date: **July 22, 2021**



### REVIEW AND CERTIFICATION

All work, calculations, and other activities and tasks performed and presented in this document were carried out by me or under my direction and supervision. I hereby certify that, to the best of my knowledge, Montrose operated in conformance with the requirements of the Montrose Quality Management System and ASTM D7036-04 during this test project.

Signature: *D. Chapman* Date: 07 / 20 / 2021  
Name: Donald Chapman, QSTI  
for Rob Burton, QI Title: Vice President, Technical  
Client Project Manager

I have reviewed, technically and editorially, details, calculations, results, conclusions, and other appropriate written materials contained herein. I hereby certify that, to the best of my knowledge, the presented material is authentic, accurate, and conforms to the requirements of the Montrose Quality Management System and ASTM D7036-04.

Signature: *Henry M. Taylor* Date: 07 / 20 / 2021  
Name: Henry M. Taylor, QSTO Title: Senior Reporting Specialist

## TABLE OF CONTENTS

<b><u>SECTION</u></b>	<b><u>PAGE</u></b>
1.0 INTRODUCTION .....	5
1.1 SUMMARY OF TEST PROGRAM .....	5
1.2 KEY PERSONNEL.....	7
2.0 PLANT AND SAMPLING LOCATION DESCRIPTIONS.....	8
2.1 PROCESS DESCRIPTION, OPERATION, AND CONTROL EQUIPMENT .....	8
2.2 SAMPLING LOCATION .....	8
2.3 OPERATING CONDITIONS AND PROCESS DATA.....	8
3.0 SAMPLING AND ANALYTICAL PROCEDURES .....	9
3.1 TEST METHODS .....	9
3.1.1 EPA Method 1.....	9
3.1.2 EPA Method 2.....	9
3.1.3 Molecular Weight .....	9
3.1.4 EPA Method 320.....	9
3.2 PROCESS TEST METHODS.....	11
4.0 TEST DISCUSSION AND RESULTS.....	12
4.1 FIELD TEST DEVIATIONS AND EXCEPTIONS .....	12
4.2 PRESENTATION OF RESULTS .....	12
5.0 INTERNAL QA/QC ACTIVITIES .....	17
5.1 QA/QC AUDITS .....	17
5.2 QA/QC DISCUSSION .....	17
5.3 QUALITY STATEMENT .....	17
 <b>LIST OF APPENDICES</b>	
A FIELD DATA AND CALCULATIONS.....	18
A.1 Sampling Locations .....	19
A.2 Field Data Sheets .....	23
A.3 FTIR Data.....	49
A.4 Calculations/Results .....	100
B FACILITY PROCESS DATA.....	129
C QUALITY ASSURANCE/QUALITY CONTROL .....	131
C.1 Units and Abbreviations .....	132
C.2 QA/QC Data .....	140
C.3 Accreditation Information/Certifications.....	159

**LIST OF TABLES**

1-1 SUMMARY OF TEST PROGRAM .....5  
1-2 SUMMARY OF AVERAGE COMPLIANCE RESULTS .....6  
1-3 TEST PERSONNEL AND OBSERVERS .....7  
2-1 SAMPLING LOCATION .....8  
4-1 VOC AND HAP EMISSIONS RESULTS - CO<sub>2</sub> SCRUBBER NO. 1 (C40) STACK  
(TEST CONDITION 1) .....13  
4-2 VOC AND HAP EMISSIONS RESULTS - CO<sub>2</sub> SCRUBBER NO. 1 (C40) STACK  
(TEST CONDITION 2) .....14  
4-3 VOC AND HAP EMISSIONS RESULTS - CO<sub>2</sub> SCRUBBER NO. 2 (C40A) STACK  
(TEST CONDITION 1) .....15  
4-4 VOC AND HAP EMISSIONS RESULTS - CO<sub>2</sub> SCRUBBER NO. 2 (C40A) STACK  
(TEST CONDITION 2) .....16

**LIST OF FIGURES**

3-1 EPA METHOD 320 SAMPLING TRAIN .....10

## 1.0 INTRODUCTION

### 1.1 SUMMARY OF TEST PROGRAM

The Andersons Marathon Holdings LLC (The Andersons) contracted Montrose Air Quality Services, LLC (Montrose) to perform compliance emissions tests at their facility located in Albion, Michigan.

The specific objectives were to:

- Determine the VOC and HAP concentrations and emission rates from the CO<sub>2</sub> Scrubbers No. 1 (C40) and No. 2 (C40A) stacks during two separate test conditions
- Conduct the test program with a focus on safety

Montrose performed the tests to measure the emission parameters listed in Table 1-1.

**TABLE 1-1  
SUMMARY OF TEST PROGRAM**

Test Date	Unit ID/ Source Name	Activity/ Parameters	Test Methods	No. of Runs	Duration (Minutes)
6/3/21	C40 & C40A/ CO <sub>2</sub> Scrubber Stacks (Test Condition 1)	Velocity/Volumetric Flow H <sub>2</sub> O, VOC, HAP	EPA 1 & 2 EPA 320	4 3	≥ 4 60
6/4/21	C40 & C40A/ CO <sub>2</sub> Scrubber Stacks (Test Condition 2)	Velocity/Volumetric Flow H <sub>2</sub> O, VOC, HAP	EPA 1 & 2 EPA 320	5 4	≥ 4 60

The compliance tests on the two scrubbers were conducted simultaneously during each of the two test conditions.

To simplify this report, a list of Units and Abbreviations is included in Appendix C.1. Throughout this report, chemical nomenclature, acronyms, and reporting units are not defined. Please refer to the list for specific details.

This report presents the test results and supporting data, descriptions of the testing procedures, descriptions of the facility and sampling location, and a summary of the quality assurance procedures used by Montrose. The average emission test results are summarized and compared to their respective permit limits in Table 1-2. Detailed results for individual test runs can be found in Section 4.0. All supporting data can be found in the appendices.

The test was conducted according to Test Plan No. MW024AS-007941-PP-297 dated April 22, 2021.

**TABLE 1-2  
 SUMMARY OF AVERAGE COMPLIANCE RESULTS**

Unit ID/Source Name	Test Date	Parameters	Units	Average Results <sup>1</sup>	Emission Limits
C40/CO <sub>2</sub> Scrubber No. 1 (Test Condition 1)	6/3/2021	Total VOC Acetaldehyde	lb/hr lb/hr	< 9.08 < 0.01	14.0 1.3
C40/CO <sub>2</sub> Scrubber No. 1 (Test Condition 2)	6/4/2021	Total VOC Acetaldehyde	lb/hr lb/hr	< 13.10 0.37	14.0 1.3
C40A/CO <sub>2</sub> Scrubber No. 2 (Test Condition 1)	6/3/2021	Total VOC Acetaldehyde	lb/hr lb/hr	< 9.38 0.18	13.0 0.93
C40A/CO <sub>2</sub> Scrubber No. 2 (Test Condition 2)	6/4/2021	Total VOC Acetaldehyde	lb/hr lb/hr	< 5.20 0.19	13.0 0.93

<sup>1</sup>Average values labeled as 'less than' identify emission rates which include one or more compounds reported at the method detection limit.

## 1.2 KEY PERSONNEL

A list of project participants is included below:

### Facility Information

Source Location:	The Andersons Marathon Holdings LLC - Albion 26250 B Drive North Albion, MI 49224	
Project Contact:	Mr. Evan Dankert	Mr. Tony Sloma
Role:	EHS Specialist II	Senior EHS Manager
Telephone:	517-629-9428	419-897-3676
Email:	evan_dankert@andersonsinc.com	tony_sloma@andersonsinc.com

### Testing Company Information

Testing Firm: Montrose Air Quality Services, LLC  
 Contact: Mr. Rob Burton  
 Title: Client Project Manager  
 Telephone: 847-487-1580 Ext. 12426  
 Email: rburton@montrose-env.com

Test personnel and observers are summarized in Table 1-3.

**TABLE 1-3  
 TEST PERSONNEL AND OBSERVERS**

Name	Affiliation	Role/Responsibility
Rob Burton	Montrose	Field Project Manager/QI/ Field Team Leader/Trailer Operator
Vannak Khy, David Koponen	Montrose	Field Technician/Field Support
Debbie Olsen	Montrose	Report Preparation
Evan Dankert, Tony Sloma	The Andersons	Client Liaison/Test Coordinator

## 2.0 PLANT AND SAMPLING LOCATION DESCRIPTIONS

### 2.1 PROCESS DESCRIPTION, OPERATION, AND CONTROL EQUIPMENT

The compliance tests were conducted on the CO<sub>2</sub> Scrubbers C40 and C40A stacks at The Andersons facility in Albion, Michigan.

### 2.2 SAMPLING LOCATION

Information regarding the sampling locations is presented in Table 2-1.

**TABLE 2-1  
 SAMPLING LOCATIONS**

Stack Sampling Location	Stack Inside Diameter (in.)	Distance from Nearest Disturbance		Number of Traverse Points
		Downstream EPA "B" (in./dia.)	Upstream EPA "A" (in./dia.)	
CO <sub>2</sub> Scrubber C40	23.5	190 / 8.0	50 / 2.1	Flow: 12 (6/port)
CO <sub>2</sub> Scrubber C40A	23.5	240 / 10.2	124 / 5.2	Flow: 12 (6/port)

The sample locations were verified in the field to conform to EPA Method 1.

### 2.3 OPERATING CONDITIONS AND PROCESS DATA

Testing was conducted under the following test conditions:

- 6/3/21: Test Condition 1 – Both Scrubbers Running with the Pre-Condenser Operating
- 6/4/21: Test Condition 2 – Both Scrubbers Running Without the Pre-Condenser Operating

Three test runs were conducted during the first test condition on June 3, 2021. Four test runs were conducted during the second test condition on June 4, 2021 because the scrubber water flow rate increased during Test Run No. 3, and an additional test run was conducted. The 3-run average for Test Run Nos. 1, 2, and 4 operating Scrubber 1 (C40) water flow at the same rate did not demonstrate compliance. Therefore, at the request of The Andersons, the test averages for the second test condition are based on Test Run Nos. 1, 2, and 3 with Test Run No. 4 data presented for completeness.

Plant personnel were responsible for establishing the test conditions and collecting all applicable unit-operating data. The process data that was provided is presented in Appendix B.



### **3.0 SAMPLING AND ANALYTICAL PROCEDURES**

#### **3.1 TEST METHODS**

The test methods for this test program were presented previously in Table 1-1. Additional information regarding specific applications or modifications to standard procedures is presented below.

##### **3.1.1 EPA Method 1, Sample and Velocity Traverses for Stationary Sources**

EPA Method 1 is used to assure that representative measurements of volumetric flow rate are obtained by dividing the cross-section of the stack or duct into equal areas, and then locating a traverse point within each of the equal areas. Acceptable sample locations must be located at least two stack or duct equivalent diameters downstream from a flow disturbance and one-half equivalent diameter upstream from a flow disturbance.

##### **3.1.2 EPA Method 2, Determination of Stack Gas Velocity and Volumetric Flow Rate (Type S Pitot Tube)**

EPA Method 2 is used to measure the gas velocity using an S-type pitot tube connected to a pressure measurement device, and to measure the gas temperature using a calibrated thermocouple connected to a thermocouple indicator. Typically, Type S (Stausscheibe) pitot tubes conforming to the geometric specifications in the test method are used, along with an inclined manometer. The measurements are made at traverse points specified by EPA Method 1. The molecular weight of the gas stream is determined from independent measurements of O<sub>2</sub>, CO<sub>2</sub>, and moisture. The stack gas volumetric flow rate is calculated using the measured average velocity head, the area of the duct at the measurement plane, the measured average temperature, the measured duct static pressure, the molecular weight of the gas stream, and the measured moisture.

Pertinent information regarding the performance of the method is presented below:

- Method Options:
  - S-type pitot tube coefficient is 0.84

##### **3.1.3 Molecular Weight**

A dry molecular weight of 44 lb/lb-mole (100% CO<sub>2</sub>) is assumed based on the process and historical data.

##### **3.1.4 EPA Method 320, Measurement of Vapor Phase Organic and Inorganic Emissions by Extractive FTIR Spectroscopy**

EPA Method 320 is an instrumental test method used to measure specific analyte concentrations for which EPA reference spectra have been developed or prepared. Extractive emission measurements are performed using FTIR spectroscopy. The FTIR analyzer is composed of a spectrometer and detector, a high optical throughput sampling cell, analysis software, and a quantitative spectral library. The analyzer collects high resolution spectra in the mid infrared spectral region (400 to 4,000 cm<sup>-1</sup>), which are analyzed using the quantitative spectral library. This provides an accurate, highly sensitive measurement of gases and vapors.

Pertinent information regarding the performance of the method is presented below:

- Method Options:
  - The specific analyte concentrations include H<sub>2</sub>O, acetaldehyde, acetic acid, acrolein, ethanol, ethyl acetate, formaldehyde, formic acid, 2-furaldehyde, and methanol
  - Continuous static sampling is performed at a flow rate of approximately 4 liters per minute
  - Previous spiking studies validate the use of FTIR spectroscopy to accurately measure the concentrations of the specific analytes from similar sources
  - A dynamic matrix spike is performed using acetaldehyde and SF<sub>6</sub> as a tracer gas
- Method Exceptions:
  - To calculate the MDL for the target analytes, the guidelines in Appendix B of 40 CFR 136 are followed using the Student t-test to calculate the MDL for each analyte at a 99% confidence level. This follows EPA guidelines for reporting of zeroes or non-detects and meets the NELAC requirements for determination of MDL values.
  - Independent calculations of optical path length are not performed because the instrument has a fixed path of 5.11 meters
- Target and/or Minimum Required Sample Duration: 60 minutes

The typical sampling system is detailed in Figure 3-1.

**FIGURE 3-1  
EPA METHOD 320 SAMPLING TRAIN**

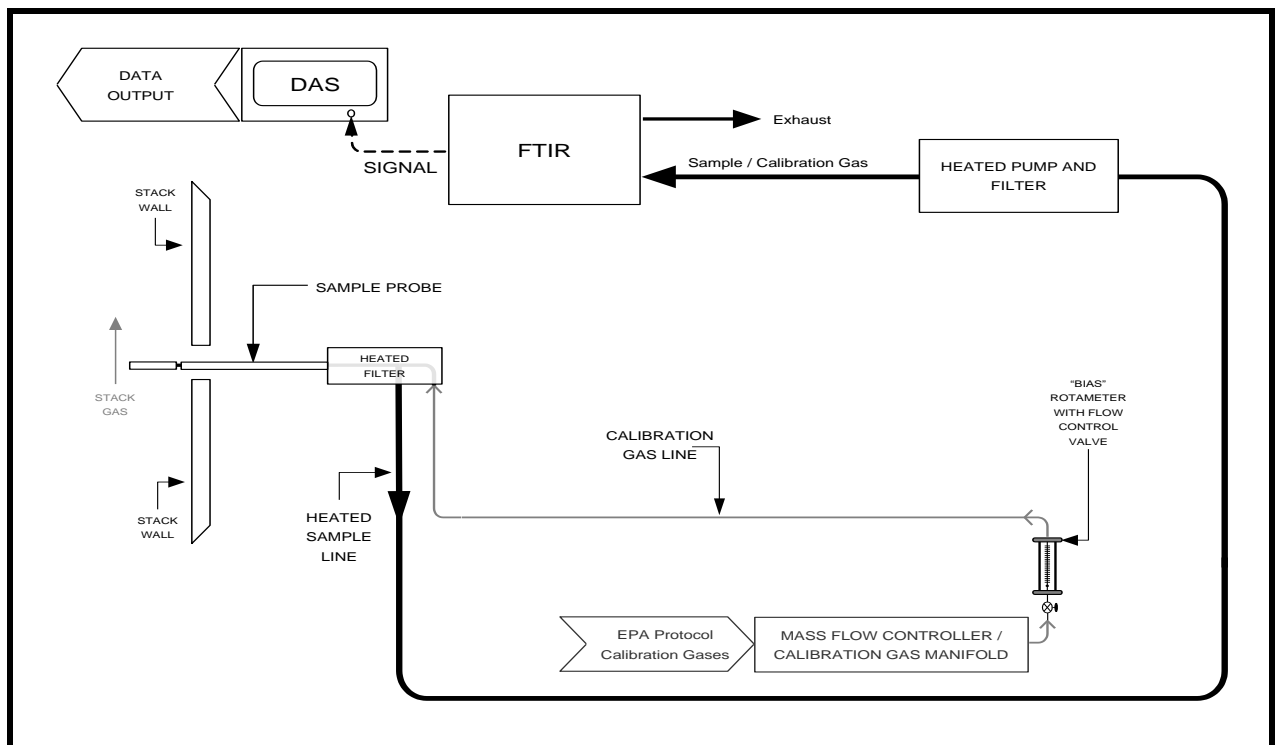

### **3.2 PROCESS TEST METHODS**

The test plan did not require that process samples be collected during this test program; therefore, no process sample data are presented in this test report.

## **4.0 TEST DISCUSSION AND RESULTS**

### **4.1 FIELD TEST DEVIATIONS AND EXCEPTIONS**

No field deviations or exceptions from the test methods occurred during this test program other than the FTIR Method 320 QC exceptions in Section 3.1.4.

### **4.2 PRESENTATION OF RESULTS**

The average results are compared to the permit limits in Table 1-2. The results of individual compliance test runs performed are presented in Tables 4-1 through 4-4. Emissions are reported in units consistent with those in the applicable regulations or requirements. Additional information is included in the appendices as presented in the Table of Contents.

**TABLE 4-1  
 VOC AND HAP EMISSIONS RESULTS -  
 CO<sub>2</sub> SCRUBBER NO. 1 (C40) STACK (TEST CONDITION 1)**

Run Number	1	2	3	Average
Date	6/3/2021	6/3/2021	6/3/2021	--
Time	14:00-15:00	15:26-16:26	16:40-17:40	--
<b>Stack Gas Parameters</b>				
temperature, °F	67.0	68.0	69.3	68.1
velocity, average ft/sec	33.2	27.3	25.9	28.8
volumetric flow rate, acfm	6,007	4,940	4,681	5,209
volumetric flow rate, scfm	5,904	4,873	4,625	5,134
volumetric flow rate, scfh	354,252	292,358	277,526	308,045
volumetric flow rate, dscfh	347,580	286,864	272,378	302,274
moisture content, % volume	1.9	1.9	1.9	1.9
CO <sub>2</sub> , % volume dry	100.0	100.0	100.0	100.0
O <sub>2</sub> , % volume dry	0.0	0.0	0.0	0.0
<b>Total VOC</b>				
lb/hr	< 10.57	< 8.70	< 7.96	< 9.08
<b>HAP - Acetaldehyde</b>				
ppmvw	< 0.14	0.19	0.34	< 0.22
lb/hr	< 0.01	0.01	0.01	< 0.01
<b>HAP - Formaldehyde</b>				
ppmvw	0.17	0.16	0.16	0.16
lb/hr	0.005	0.004	0.004	0.004
<b>HAP - Methanol</b>				
ppmvw	< 0.07	< 0.07	< 0.07	< 0.07
lb/hr	< 0.002	< 0.002	< 0.002	< 0.002
<b>HAP - Acrolein</b>				
ppmvw	1.60	1.57	1.50	1.56
lb/hr	0.08	0.07	0.06	0.07
<b>Total HAP</b>				
ppmvw	< 1.98	< 1.99	< 2.08	< 2.02
lb/hr	< 0.09	< 0.08	< 0.08	< 0.08

**TABLE 4-2  
 VOC AND HAP EMISSIONS RESULTS -  
 CO<sub>2</sub> SCRUBBER NO. 1 (C40) STACK (TEST CONDITION 2)**

Run Number	1	2	3	4*	Average
<b>Date</b>	6/4/2021	6/4/2021	6/4/2021	6/4/2021	--
<b>Time</b>	10:15-11:15	11:33-12:33	13:01-14:01	14:15-15:15	--
<b>Stack Gas Parameters</b>					
temperature, °F	65.1	67.5	66.6	66.4	66.4
velocity, average ft/sec	42.8	42.6	42.1	42.0	42.5
volumetric flow rate, acfm	7,736	7,701	7,604	7,596	7,680
volumetric flow rate, scfm	7,671	7,604	7,524	7,518	7,600
volumetric flow rate, scfh	460,244	456,261	451,431	451,061	455,978
volumetric flow rate, dscfh	452,167	448,059	443,790	442,743	448,005
moisture content, % volume	1.8	1.8	1.7	1.8	1.7
CO <sub>2</sub> , % volume dry	100.0	100.0	100.0	100.0	100.0
O <sub>2</sub> , % volume dry	0.0	0.0	0.0	0.0	0.0
<b>Total VOC</b>					
lb/hr	< 12.80	< 13.86	< 12.64	< 16.00	< 13.10
<b>HAP - Acetaldehyde</b>					
ppmvw	6.54	7.37	7.63	8.57	7.18
lb/hr	0.34	0.38	0.39	0.44	0.37
<b>HAP - Formaldehyde</b>					
ppmvw	0.15	0.14	0.15	0.17	0.15
lb/hr	0.005	0.005	0.005	0.006	0.005
<b>HAP - Methanol</b>					
ppmvw	< 0.07	< 0.07	< 0.07	< 0.07	< 0.07
lb/hr	< 0.003	< 0.003	< 0.003	< 0.003	< 0.003
<b>HAP - Acrolein</b>					
ppmvw	0.73	1.15	1.13	2.16	1.00
lb/hr	0.05	0.08	0.07	0.14	0.07
<b>Total HAP</b>					
ppmvw	< 7.50	< 8.73	< 8.98	< 10.97	< 8.40
lb/hr	< 0.40	< 0.47	< 0.48	< 0.59	< 0.45

\*Test Run No. 4 is not included in the test averages (see Section 2.3 on Page 8).

**TABLE 4-3  
 VOC AND HAP EMISSIONS RESULTS -  
 CO<sub>2</sub> SCRUBBER NO. 2 (C40A) STACK (TEST CONDITION 1)**

Run Number	1	2	3	Average
Date	6/3/2021	6/3/2021	6/3/2021	--
Time	14:00-15:00	15:26-16:26	16:40-17:40	--
<b>Stack Gas Parameters</b>				
temperature, °F	66.7	67.9	66.9	67.2
velocity, average ft/sec	26.9	29.4	33.0	29.8
volumetric flow rate, acfm	4,860	5,310	5,973	5,381
volumetric flow rate, scfm	4,828	5,238	5,875	5,314
volumetric flow rate, scfh	289,708	314,293	352,518	318,839
volumetric flow rate, dscfh	283,218	307,543	344,396	311,719
moisture content, % volume	2.2	2.1	2.3	2.2
CO <sub>2</sub> , % volume dry	100.0	100.0	100.0	100.0
O <sub>2</sub> , % volume dry	0.0	0.0	0.0	0.0
<b>Total VOC</b>				
lb/hr	< 8.55	< 8.89	< 10.71	< 9.38
<b>HAP - Acetaldehyde</b>				
ppmvw	5.26	4.51	5.18	4.98
lb/hr	0.17	0.16	0.21	0.18
<b>HAP - Formaldehyde</b>				
ppmvw	0.13	0.15	0.12	0.13
lb/hr	0.003	0.004	0.003	0.003
<b>HAP - Methanol</b>				
ppmvw	< 0.25	< 0.25	< 0.25	< 0.25
lb/hr	< 0.01	< 0.01	< 0.01	< 0.01
<b>HAP - Acrolein</b>				
ppmvw	3.40	3.18	3.46	3.35
lb/hr	0.14	0.15	0.18	0.16
<b>Total HAP</b>				
ppmvw	< 9.05	< 8.08	< 9.02	< 8.72
lb/hr	< 0.33	< 0.32	< 0.40	< 0.35

**TABLE 4-4  
 VOC AND HAP EMISSIONS RESULTS -  
 CO<sub>2</sub> SCRUBBER NO. 2 (C40A) STACK (TEST CONDITION 2)**

Run Number	1	2	3	4*	Average
Date	6/4/2021	6/4/2021	6/4/2021	6/4/2021	--
Time	10:15-11:15	11:33-12:33	13:01-14:01	14:15-15:15	--
<b>Stack Gas Parameters</b>					
temperature, °F	57.7	57.6	57.9	57.8	57.8
velocity, average ft/sec	37.9	35.9	34.5	29.8	36.1
volumetric flow rate, acfm	6,856	6,488	6,240	5,387	6,528
volumetric flow rate, scfm	6,929	6,557	6,302	5,439	6,596
volumetric flow rate, scfh	415,728	393,419	378,090	326,344	395,746
volumetric flow rate, dscfh	409,542	387,781	372,632	321,832	389,985
moisture content, % volume	1.5	1.4	1.4	1.4	1.5
CO <sub>2</sub> , % volume dry	100.0	100.0	100.0	100.0	100.0
O <sub>2</sub> , % volume dry	0.0	0.0	0.0	0.0	0.0
<b>Total VOC</b>					
lb/hr	< 5.84	< 4.83	< 4.92	< 3.24	< 5.20
<b>HAP - Acetaldehyde</b>					
ppmvw	4.33	3.76	4.32	2.90	4.14
lb/hr	0.21	0.17	0.19	0.11	0.19
<b>HAP - Formaldehyde</b>					
ppmvw	0.12	0.11	0.10	0.09	0.11
lb/hr	0.004	0.003	0.003	0.002	0.003
<b>HAP - Methanol</b>					
ppmvw	< 0.25	< 0.25	< 0.25	< 0.25	< 0.25
lb/hr	< 0.01	< 0.01	< 0.01	< 0.01	< 0.01
<b>HAP - Acrolein</b>					
ppmvw	1.19	1.01	1.17	0.45	1.12
lb/hr	0.07	0.06	0.06	0.02	0.06
<b>Total HAP</b>					
ppmvw	< 5.89	< 5.13	< 5.84	< 3.69	< 5.62
lb/hr	< 0.29	< 0.24	< 0.26	< 0.14	< 0.26

\*Test Run No. 4 is not included in the test averages (see Section 2.3 on Page 8).



## **5.0 INTERNAL QA/QC ACTIVITIES**

### **5.1 QA/QC AUDITS**

The EPA Method 320 performance parameters measured included signal to noise tests, noise equivalent absorbance (NEA), detector linearity, background spectra, potential interferences, and cell and system leakage. Quality assurance procedures included baseline measurement with ultra-high purity nitrogen, measurement of a calibration transfer standard (~100 ppm ethylene), direct analyte calibration measurements, and measurements to determine baseline shift. SF<sub>6</sub> was also used as a tracer gas in the calibration gases to verify the sample delivery system integrity. The method QA/QC criteria were met.

### **5.2 QA/QC DISCUSSION**

All QA/QC criteria were met during this test program.

### **5.3 QUALITY STATEMENT**

Montrose is qualified to conduct this test program and has established a quality management system that led to accreditation with ASTM Standard D7036-04 (Standard Practice for Competence of Air Emission Testing Bodies). Montrose participates in annual functional assessments for conformance with D7036-04 which are conducted by the American Association for Laboratory Accreditation (A2LA). All testing performed by Montrose is supervised on site by at least one QI as defined in D7036-04 Section 8.3.2. Data quality objectives for estimating measurement uncertainty within the documented limits in the test methods are met by using approved test protocols for each project as defined in D7036-04 Sections 7.2.1 and 12.10. Additional quality assurance information is included in the report appendices. The content of this report is modeled after the EPA Emission Measurement Center Guideline Document (GD-043).