

RECEIVED

APR 27 2018

AIR QUALITY DIVISION

Compliance Stack Emission Test Report

Determination of Total Chromium Emissions

EPA Methods 1, 2, 4, and 306

Hard Chrome Plating Tank (EUPLATE)

Test Date(s): March 14, 2018
Source Location: Sturgis, Michigan

Report Date: April 12, 2018
Report Number: 171110.1.0
Scope ID: 11166

Prepared For:
Burr Oak Tool, Inc.
405 W. South Street • Sturgis, Michigan 49091

Prepared By:
MAQS
PO Box 41156 • Cleveland, OH 44141
Phone: (440) 262-3760



RECEIVED**APR 27 2018****1.0 INTRODUCTION****AIR QUALITY DIVISION****1.1 Summary of Test Program**

Burr Oak Tool, Inc. located in Sturgis, Michigan, contracted Montrose Air Quality Services (MAQS) of Cleveland, Ohio, to conduct compliance stack emission testing for their Hard Chrome Plating Tank (EUPLATE). Testing was performed to satisfy the emissions testing requirements pursuant to the National Emission Standards for Hazardous Air Pollutants (NESHAP) as specified in 40 CFR Part 63 Subparts A and N and Michigan Department of Environmental Quality (MDEQ) Permit-to-Install (PTI) No. 72-17. The testing was performed on March 14, 2018.

Sampling was performed at the Multi-Stage Composite Mesh Pad System (CMP) Exhaust Stack (SVCHROME) associated with EUPLATE to determine the emissions of total chromium (Total Cr). Testing was conducted while EUPLATE was operating at or near maximum capacity. During this test, emissions from EUPLATE were controlled by the CMP.

The test methods that were conducted during this test were EPA Methods 1, 2, 4, and 306.

1.2 Key Personnel

The key personnel who coordinated this test program (and their phone numbers) were:

Ron Sprowls, Safety Director, Burr Oak Tool, Inc., 269-651-9393

Brad Stephenson, Consultant- Environmental Engineering, Hixson Inc., 513-241-1230

Dennis Dunlap, Michigan Department of Environmental Quality (MDEQ), 269-567-3553

Tom Gasloli, Michigan Department of Environmental Quality (MDEQ), 269-567-3554

Walter Mummert III, QI, Field Project Manager, MAQS, 800-372-2471

2.0 SUMMARY AND DISCUSSION OF TEST RESULTS

2.1 Objectives and Test Matrix

The purpose of this test was to determine the emissions of Total Cr at the CMP Exhaust Stack while EUPLATE was operating at or near maximum capacity. Testing was performed to satisfy the emissions testing requirements pursuant to NESHAP 40 CFR Part 63 Subparts A and N and MDEQ PTI No. 72-17.

The specific test objectives for this test were as follows:

Measure the concentration of Total Cr at the CMP Exhaust Stack.

Measure the actual and dry standard volumetric flow rate of the stack gas at the CMP Exhaust Stack.

Utilize the above variables to determine the emissions of Total Cr at the CMP Exhaust Stack while EUPLATE was operating at or near maximum capacity.

Table 2.1 presents the sampling and analytical matrix log for this test.

2.2 Field Test Changes and Problems

2.2.1 Only EUPLATE was in Operation during testing.

The Hard Chrome Plating Line (FGCHROME) (EUPLATE and chrome reverse etch tank (EUETCH)) exhausts to a multi-stage Composite Mesh Pad System (CMP). Given the significant difference in the operating times between the EUETCH (15-seconds) and EUPLATE (1 20-minutes), MDEQ and Burr Oak Tool, Inc. agreed to only have EUPLATE operating during the test event

2.2.2 Use of 29.0 g/g-mole as the Molecular Weight of the Stack Gas

Tom Gasloli, MDEQ, directed MAQS Personnel to utilize a dry molecular weight value of 29.0 g/g-mole (EPA Method 2, Section 8.6) at the CMP Exhaust Stack. Therefore, no samples were collected for EPA Method 3 analysis.

2.3 Presentation of Results

A single sampling train was utilized during each run at the CMP Exhaust Stack to determine the emissions of Total Cr. This sampling train measured the stack gas volumetric flow rate, moisture content, and concentration of Total Cr.

Table 2.2 displays the emissions of Total Cr measured at the CMP Exhaust Stack while EUPLATE was operating at near or maximum capacity.

Date	Run No.	Sampling Location	EPA TEST METHODS UTILIZED		
			M1/M2 (Flow)	M4 (%H ₂ O)	M306 (Total Cr)
			Sampling Time / Duration (min)	Sampling Time / Duration (min)	Sampling Time / Duration (min)
3/14/2018	1	CMP Exhaust Stack	8:10 - 10:20 120	8:10 - 10:20 120	8:10 - 10:20 120
3/14/2018	2	CMP Exhaust Stack	11:00 - 13:10 120	11:00 - 13:10 120	11:00 - 13:10 120
3/14/2018	3	CMP Exhaust Stack	13:50 - 16:00 120	13:50 - 16:00 120	13:50 - 16:00 120

All times are Eastern Daylight Time.

Table 2.1 - Sampling and Analytical Matrix

	CMP Exhaust Stack			
	Run 1	Run 2	Run 3	Average
Metals Processed (lb)*	4,228	4,228	4,228	4,228
EUPLATE Rectifier Output (amp-hr/hr)*	152	176	160	163
Measured Chromium Concentration (mg/dscm)	0.0035	0.0029	0.0031	0.0031
Chromium Emission Factor (mg/amp-hr)	0.208	0.151	0.177	0.178
Stack Gas Average Flow Rate (acfm)	5,530	5,590	5,553	5,558
Stack Gas Average Flow Rate (scfm)	5,395	5,470	5,419	5,428
Stack Gas Average Flow Rate (dscfm)	5,365	5,439	5,387	5,397
Stack Gas Average Velocity (fpm)	3,293	3,328	3,306	3,309
Stack Gas Average Static Pressure (in-H ₂ O)	-0.17	-0.15	-0.18	-0.17
Stack Gas Average Temperature (°F)	64	62	64	63
Stack Gas Percent by Volume Moisture (%H ₂ O)	0.55	0.56	0.60	0.57
Measured Stack Inner Dimension (in)†	17.8 X 17.3	17.8 X 17.3	17.8 X 17.3	17.8 X 17.3

* Process data was provided by Burr Oak Tool Inc. personnel.

† The CMP Exhaust Stack was elliptical in shape.

Table 2.2 - Emission Results

3.0 PLANT AND SAMPLING LOCATION DESCRIPTIONS

3.1 Process Description and Operation

Burr Oak Tool, Inc. provides tools and expertise to the heat transfer and tube processing industries. The Hard Chrome Plating Line (FGCHROME) includes a chrome reverse etch tank operating with a hexavalent chromic acid solution and bussed for a 500-AMP rectifier (EUETCH) and a hard chrome electroplating tank operating with a hexavalent chromic acid solution and bussed for a 1,000-AMP rectifier (EUPLATE). Only EUPLATE was in operation during the test event. See Section 2.2.1 for details.

Figure 3.1 depicts the process and sampling location.

3.2 Control Equipment Description

During this test, emissions from EUPLATE were controlled by the CMP.

3.3 Flue Gas Sampling Locations

The CMP Exhaust Stack was elliptical in shape with measured inner diameters of 17.8-inches and 17.3-inches. The stack was oriented in the vertical plane and was accessed using a manlift. Two 3.0-inch I.D. sampling ports were located 90° apart from one another at a location that met EPA Method 1, Section 11.1.1 criteria. Prior to emissions sampling, the stack was traversed to verify the absence of cyclonic flow. An average yaw angle of 15.0° was measured. Therefore, the sampling location also met EPA Method 1, Section 11.4.2 criteria. During emissions sampling, the stack was traversed for stack gas volumetric flow rate, moisture content, and Total Cr concentration determinations.

Figure 3.2 schematically illustrates the traverse point and sample port locations utilized.

3.4 Process Sampling Location

The EPA Reference Test Methods performed did not specifically require that process samples were to be taken during the performance of this testing event. It is in the best knowledge of MAQS that no process samples were obtained and therefore no process sampling location was identified in this report.

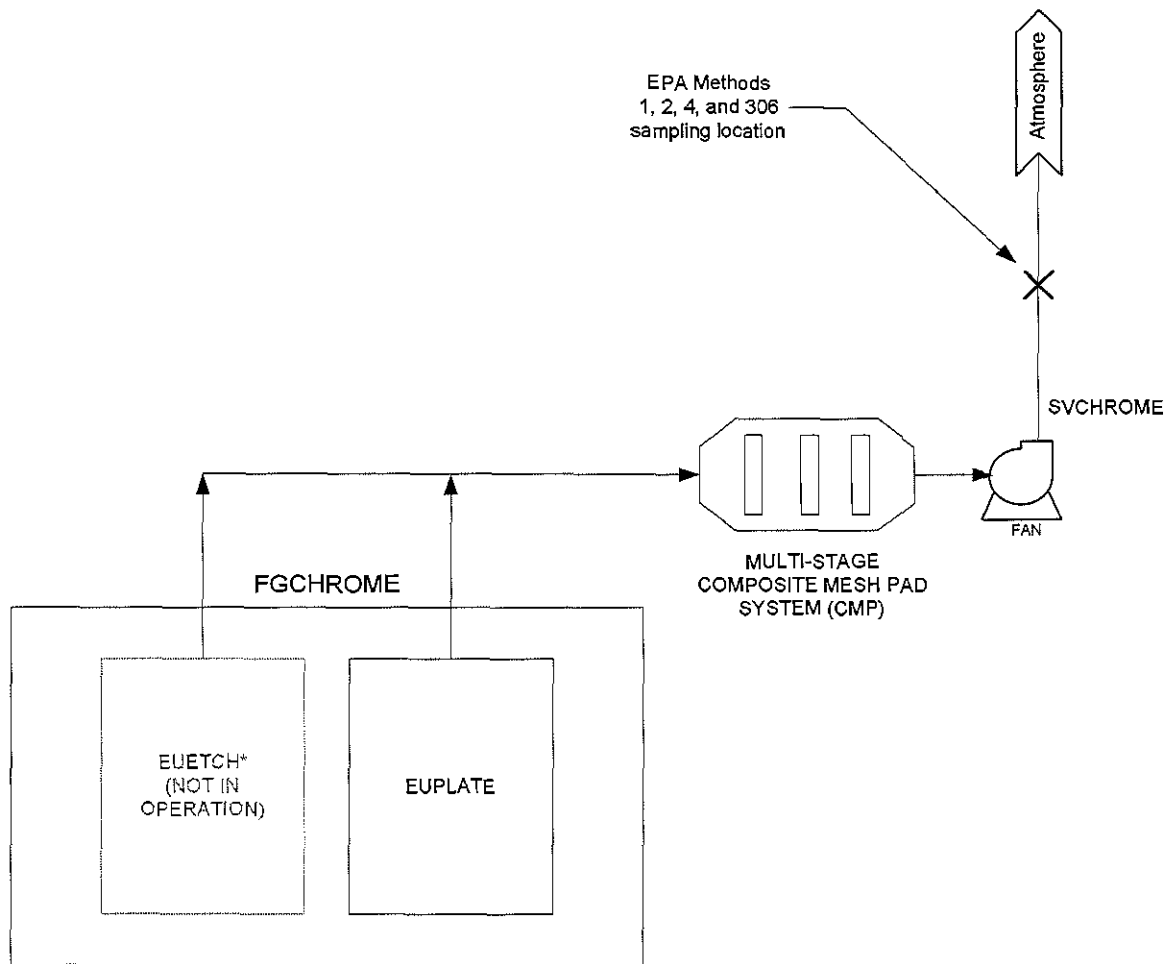

* See Section 2.2.1 of this report for details

Figure 3.1 - FGCHROME Process/Sampling Location Schematic

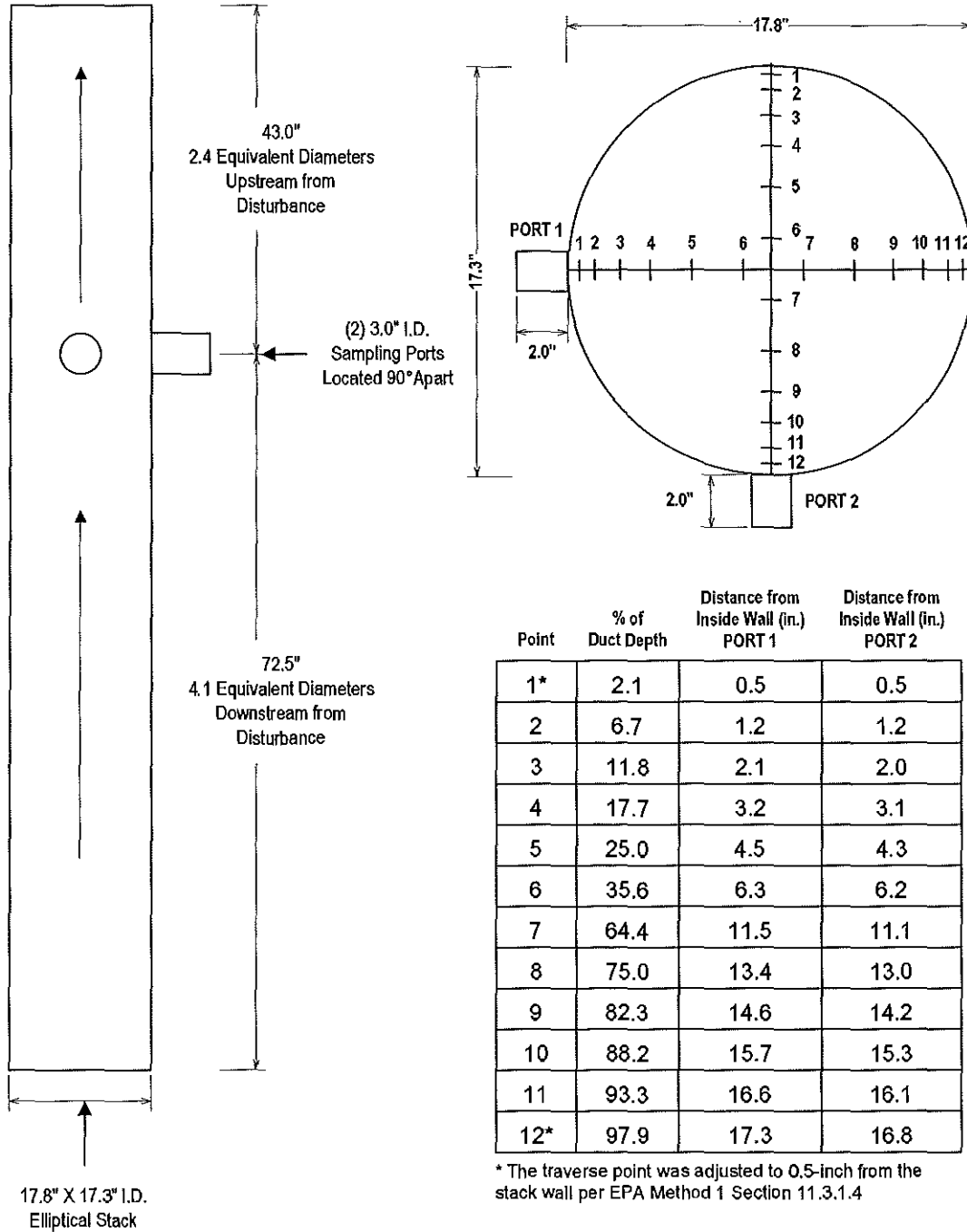

Figure 3.2 - CMP Exhaust Stack Traverse Point Location Drawing

4.0 SAMPLING AND ANALYTICAL PROCEDURES

4.1 Test Methods

4.1.1 EPA Method 1: *"Sample and Velocity Traverses for Stationary Sources"*

Principle: To aid in the representative measurement of pollutant emissions and/or total volumetric flow rate from a stationary source, a measurement site where the effluent stream is flowing in a known direction is selected, and the cross-section of the stack is divided into a number of equal areas. Traverse points are then located within each of these equal areas. This method was utilized in its entirety as per the procedures outlined in 40 CFR Part 60, Appendix A.

4.1.2 EPA Method 2: *"Determination of Stack Gas Velocity and Volumetric Flow Rate (Type S)"*

Principle: The average gas velocity in a stack is determined from the gas density and from measurement of the average velocity head with a Type S (Stausscheibe or reverse type) pitot tube. This method was utilized in its entirety as per the procedures outlined in 40 CFR Part 60, Appendix A.

4.1.3 EPA Method 4: *"Determination of Moisture Content in Stack Gases"*

Principle: A gas sample is extracted at a constant rate from the source; moisture is removed from the sample stream and determined either volumetrically or gravimetrically. This method was utilized in its entirety as per the procedures outlined in 40 CFR Part 60, Appendix A.

4.1.4 EPA Method 306: *"Determination of Chromium Emissions from Decorative and Hard Chromium Electroplating and Anodizing Operations"*

Principle: An emission sample is extracted isokinetically from the source using an unheated Method 5 sampling train (40 CFR Part 60, Appendix A), with a glass nozzle and probe liner, but with the filter omitted. The sample time shall be at least two hours. The Cr emissions are collected in an alkaline solution containing 0.1 N sodium hydroxide (NaOH) or 0.1 N sodium bicarbonate (NaHCO₃). The collected samples are recovered using an alkaline solution and are then transported to the laboratory for analysis. This method was utilized in its entirety as per the procedures outlined in 40 CFR Part 63, Appendix A.

The sampling train utilized during this testing project is depicted in Figure 4.1.

4.2 Procedures for Obtaining Process Data

Process data was recorded by Burr Oak Tool, Inc. personnel utilizing their typical record keeping procedures. Recorded process data was provided to MAQS personnel at the conclusion of this test event. The process data is located in Table 2.2 and in the Process Data section of the Appendix.

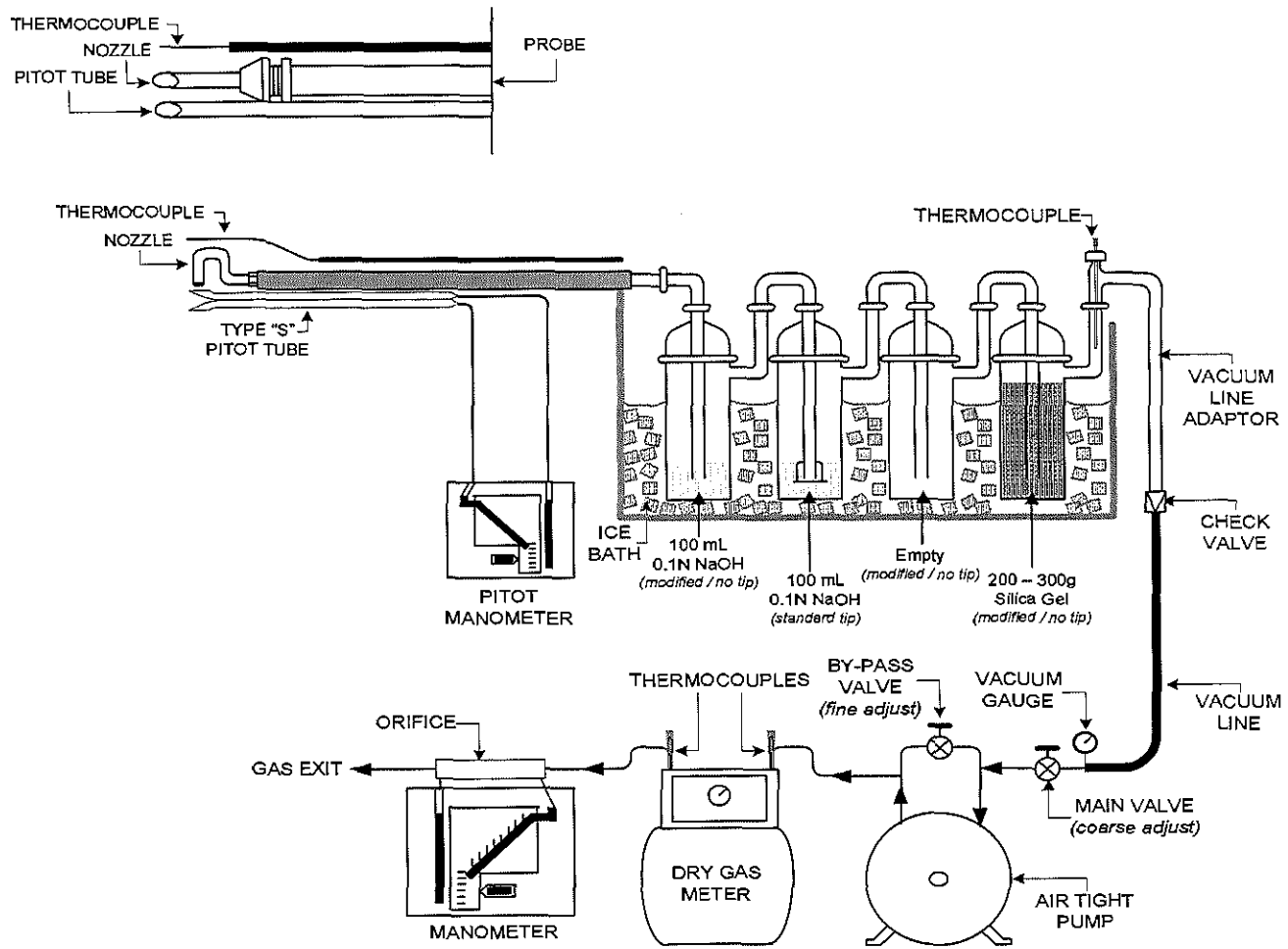

Figure 4.1 - EPA Method 306 Sampling Train Schematic

5.0 INTERNAL QA/QC ACTIVITIES

5.1 QA Audits

Tables 5.1-5.3 illustrate the QA audits that were performed during this test.

All meter boxes and sampling trains used during sampling performed within the requirements of their respective methods as is shown in Tables 5.1 and 5.2. All post-test leak checks were well below the applicable limit. Minimum metered volumes and percent isokinetics were also met where applicable.

Table 5.3 displays the laboratory QA results for EPA Method 306. The spike recovery for total Cr was within the 70% and 130% requirement as per EPA Method 306 Section 9.1.6.1.

5.2 QA/QC Problems

No QA/QC problems occurred during this test event.

5.3 Measurement Uncertainty Statement

Both qualitative and quantitative factors contribute to field measurement uncertainty and should be taken into consideration when interpreting the results contained within this report. Whenever possible, MAQS personnel reduce the impact of these uncertainty factors through the use of approved and validated test methods. In addition, MAQS personnel perform routine instrument and equipment calibrations and ensure that the calibration standards, instruments, and equipment used during test events meet, at a minimum, test method specifications as well as the specifications of our Quality Manual and American Society for Testing and Materials (ASTM) D 7036-04. The limitations of the various methods, instruments, equipment, and materials utilized during this test have been reasonably considered, but the ultimate impact of the cumulative uncertainty of this project is not fully identified within the results of this report.

Method 306 Sampling Train	CMP Exhaust Stack		
	Run 1	Run 2	Run 3
Post-Test Leak Rate Observed (cfm)	0.000	0.000	0.000
Applicable Method Allowable Leak Rate (cfm)	0.020	0.020	0.020
Acceptable	Yes	Yes	Yes
Volume of Dry Gas Collected (dscf)	69.231	73.710	71.041
Recommended Volume of Dry Gas Collected (dscf)	60.000	60.000	60.000
Acceptable	Yes	Yes	Yes
Percent of Isokinetic Sampling Rate (%)	98.9	99.4	101.1
Applicable Method Allowable Isokinetic Sampling Rate (%)	100 ± 10	100 ± 10	100 ± 10
Acceptable	Yes	Yes	Yes

Table 5.1 - Sampling Train Audit Results

CMP Exhaust Stack - EPA Method 306 Sampling Train				
Pre-Test Dry Gas Meter Calibration Factor (Y)	Average Post-Test Dry Gas Meter Calibration Check Value (Yqa)	Post Test Dry Gas Meter Calibration Check Value Difference From Pre-Test Calibration Factor (%)	Applicable Method Allowable Difference (%)	Acceptable
1.0012	1.0000	0.12%	5.00%	Yes

Table 5.2 - Dry Gas Meter Audit Results

	Total Cr
Spike Recovery (%)	98.6
Acceptable per Applicable Method (Yes / No) (Expected Range 70% - 130%)	YES

Table 5.3 - EPA Method 306 Laboratory Recovery Analysis Results