

**FLARE PERFORMANCE TEST REPORT
DECEMBER 2019**

As Defined By The

Code of Federal Regulations; Title 40 Part 60, Subpart WWW & Michigan State Operating Permit

RMCEINC Project #2019-22016

**ADVANCED DISPOSAL SERVICES - ARBOR HILLS LANDFILL, INC.
NORTHVILLE, MICHIGAN**

**Michigan Permit to Install #: 79-17 (2018)
Michigan Renewable Operating Permit #: MI-ROP-N2688-2011a
State Registration No: N2688**

**TWO (2) ENCLOSED LANDFILL GAS FLARES
(FGENCLOSED FLARES-S2 (EUENCLOSEDFLARE1-S2 & EUENCLOSEDFLARE2-S2))**

**PREPARED FOR:
ADVANCED DISPOSAL SERVICES – Arbor Hills Landfill, Inc.**

**BY:
RMC ENVIRONMENTAL, INC. – CHICAGO REGIONAL OFFICE**

REPORT CERTIFICATION

The sampling, analysis, and data collection performed for this report were carried out under my direction and supervision, and I hereby certify that the test report is authentic and accurate, to the best of my knowledge.

Date 01/20/2020

Signature 

Rachel Chleborowicz, QSTI
Sr. Project Manager
RMC ENVIRONMENTAL, INC.

TABLE OF CONTENTS

1.0 INTRODUCTION2
 1.1 Company Information2
 1.2 Test Information2

2.0 EMISSION SOURCE INFORMATION.....2
 2.1 Facility Description, Process Information, and Emission Source Description2

3.0 SOURCE TEST PROGRAM DESCRIPTION3
 3.1 Test Contractor3
 3.2 Test Program Organization3
 3.3 Test Program Objectives4

4.0 REFERENCE TEST EQUIPMENT AND PROCEDURES5
 4.1 Instrumentation and Equipment Procedures.....5
 4.1.2 Performance Testing – VOC/NMOC.....7
 4.1.3. Fuel Analysis Testing (EPA Method 19).....7
 4.2 Test Methods8
 4.3 Analytical Methods8
 4.4 Sampling Site Location8
 4.5 Sample Matrix8

5.0 QUALITY ASSURANCE AND EQUIPMENT CALIBRATION8

6.0 SOURCE TEST REPORT.....8
 6.1 Report Format.....8
 6.2 Data Reduction Procedures/ Methods8

APPENDIX A. REFERENCE DATA SUMMARY.....14

APPENDIX B. INSTRUMENTAL TEST DATA.....17
 Calibration Summaries
 Instrumental Test Run Data

APPENDIX C. MOISTURE DATA.....35

APPENDIX D. REFERENCE MEASUREMENT SYSTEM PERFORMANCE TEST DATA.....38
 Example Calculations
 Calibration Gas Certificates of Analysis

APPENDIX E. PROCESS DATA59

LIST OF TABLES AND FIGURES

FIGURE 2.1-1 ADS Arbor Hills Landfill – Flare Diagram 3
TABLE 3.3-1 Performance Test Results and Permitted Limits 4
TABLE 3.3-2 Performance Test Results and Permitted Limits 5
TABLE 4.1-1 Reference Method Analyzers 6
TABLE 4.1-2 STRATIFICATION TABLE 6
FIGURE 4.1-1 Reference Method Gas Sampling System Diagram 7
FIGURE 6.2-1 Example Calculations 9
FIGURE 6.2-1 Example Calculations (Continued)..... 10

1.0 INTRODUCTION

1.1 Company Information

Name & Mailing Address:	FACILITY Advanced Disposal Services Arbor Hills Landfill, Inc. 10690 W Six Mile Road Northville, Michigan 48168
Contact:	Mr. Randy Frank
Title:	Lead Region Landfill Gas Manager
Telephone Number:	414-422-9075 ext. 102
Email:	randy.frank@advanceddisposal.com

Michigan PTI Number:	79-17 (2018)
Michigan ROP Number:	MI-ROP-N2688-2011a
Registration No:	N2688
Source to be tested:	Two (2) enclosed flares (EUENCLOSEDFLARE1-S2 & EUENCLOSED FLARE2-S2)

1.2 Test Information

Test Requested By:	Advanced Disposal Services – Arbor Hills Landfill, Inc.	Advanced Disposal Services – Arbor Hills Landfill, Inc.
Source Contact:	Mr. Anthony Testa	Mr. Anthony Testa
Telephone Number:	734-718-4262	734-718-4262
Test Objective:	Title 40 CFR Part 60, Subpart WWW and State Operating Permit testing	
Test Methods:	1, 3A, 4, 7E, 10, 19 and 25A	
Test Dates:	December 19, 2019	
Source Test Coordinators:	Anthony Testa	ADS – Arbor Hills Landfill, Inc.
On-Site RMCEINC Supervisor:	Rachel Chleborowicz,	RMC Environmental, Inc. (RMCEINC)
Agency Personnel:	Mr. Mark Dzadosz Ms. Diane Kavanaugh-Vetort	Michigan Dept of Environmental Quality Michigan Dept of Environmental Quality

2.0 EMISSION SOURCE INFORMATION

2.1 Facility Description, Process Information, and Emission Source Description

The flares installed at the Arbor Hills landfill were refurbished by the facility from October 2, 2019 through November 12, 2019. A representative schematic of the flares is shown in **Figure 2.1-1**.

The flare testing is required to show compliance with the existing Permit to Install (PTI) 79-17 and 40 CFR 60 Subpart WWW (NSPS WWW) . Proper operating temperatures are established during stack testing in accordance to NSPS WWW.

EUENCLOSEDFLARE2-S2 is also referred to as Flare 391 (McGill Flare)

EUENCLOSEDFLARE1-S2 is also referred to as Flare 392 (Zink Flare)

FIGURE 2.1-1 ADS Arbor Hills Landfill – Example Flare Diagram

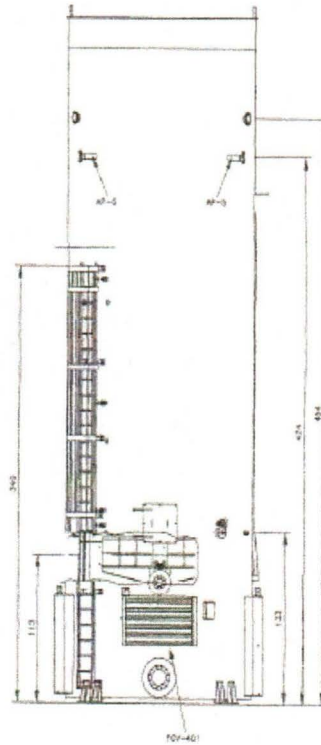

Stack Information

	Flare – 391 & 392
Shape of the test plane	Round
Internal diameter	~156"
Reference sampling system approximate height (AGL)	~50'
Flare391 – Tested Max SCFM	4,600
Flare 392 – Tested Max SCFM	3,400

3.0 SOURCE TEST PROGRAM DESCRIPTION

3.1 Test Contractor

Name and Address:	RMC ENVIRONMENTAL, INC. (RMCEINC) 9226 North 2 nd Street, Suite D Machesney Park, Illinois 61115	
Contact:	Rachel Chleborowicz – Sr. Project Manager	
Telephone Number:	815-378-6150 Mobile 815-425-1102 Fax RMCE@AirMonitoring.com	

3.2 Test Program Organization

Test Team Participants:	Rachel Chleborowicz Gregory McDermand	RMCEINC, Sr. Project Manager RMCEINC, Asst Project Manager
Site Coordinator:	Anthony Testa	Arbor Hills Landfill
Test Dates:	December 19, 2019	
Project Number:	2019-22016	

3.3 Test Program Objectives

This certification test program for the enclosed flares employed at the Arbor Hills Landfill in Northville, Michigan was conducted to demonstrate compliance with the emission limitations in the PTI and NSPS WWS and establish operating parameters.

The testing procedures were consistent with the protocol submitted on October 18, 2019 and approved by the Michigan Department of Environment, Great Lakes and Energy Air Quality Division (EGLE-AQD) on December 12, 2019. The testing was witnessed by Mr. Mark Dzadosz and Ms. Diane Kavanaugh-Vetort representing the EGLE-AQD.

The compliance program consisted of a series of three (3) test runs at the outlet of the flares. Each outlet test run determined the concentrations of oxygen (O₂), oxides of nitrogen (NO_x), carbon monoxide (CO) and non-methane organic compounds (NMOCs). All data is presented in **Appendix B** to this report. Moisture was also determined at the outlet locations utilizing EPA Method 4.

Testing was conducted under the following operating scenarios:

EUENCLOSED FLARE2 – S2: The testing on Flare 391 (The McGill Flare) was conducted while operating the flare at the maximum landfill gas flow approximately 4,500 scfm.

EUENCLOSEDFLARE1 - S2: Flare 392 (The Zink Flare) was tested at two flow rates; 1). at the 2016 landfill gas flow capacity (approximately 2,600 scfm) and 2). at the maximum landfill gas flow (approximately 3,400 scfm)

Arbor Hills Landfill retained RMC Environmental, Inc. of Machesney Park, Illinois to provide sampling and analytical support. RMC Environmental, Inc. was responsible for the collection of all gas samples. The Process data was obtained from the Unison Control Data Acquisition System that collects the flare’s operating and control data.

Tables 3.3-1 & 3.3-3 present the compliance test data and operating parameters for the flare testing. All parameters met the requirements outlined in the PTI and NSPS WWS.

TABLE 3.3-1 Performance Test Results and Permitted Limits

Parameter	Run 1	Run 3	Run 3	Average	Permit Limit
EUENCLOSED FLARE2 – S2: Flare391 (McGill) – 12/19/2019					
Run Times	1117-1217	1232-1332	1345-1445		
% O ₂	11.59	11.93	11.58	11.70	
Moisture (%)	8.4	8.3	8.5	8.4	
NO _x lb/mmBtu	0.04	0.04	0.04	0.04	0.060 lb/mmBtu
CO lb/mmBtu	0.02	0.02	0.02	0.02	0.20 lb/mmBtu
NMOC as C ₃ H ₈ ppmvd	3.32	4.17	3.33	3.58	None
NMOC (ppmvd, as Hexane @ 3% O ₂)	3.20	4.16	3.19	3.52	20 ppmvd, as Hexane @ 3% O ₂
FLARE OPERATING PARAMETERS					
Fuel Flow (scfm)	4,593	4,576	4,487	4,552	
Flare Temperature (°F)	1,514	1,524	1,523	1,520	
Inlet Methane (%)	48.44				
Suflur ppmvd	10.4 ppm				

TABLE 3.3-2 Performance Test Results and Permitted Limits

Parameter	Run 1	Run 3	Run 3	Average	Permit Limit
EUENCLOSEDFLARE1-S2 (Flare392 (Zink) – 12/19/2019					
Run Times	1115-1215	1230-1330	1345-1445		
% O ₂	12.99	13.05	13.19	13.08	
Moisture (%)	8.5	8.3	8.3	8.4	
NOx lb/mmBtu	0.04	0.04	0.04	0.04	0.060 lb/mmBtu
CO lb/mmBtu	0.06	0.06	0.04	0.05	0.20 lb/mmBtu
NMOC as C ₃ H ₈ ppmvd	0.22	0.42	1.58	0.73	None
NMOC (ppmvd, as Hexane @ 3% O ₂)	0.24	0.48	1.83	0.85	20 ppmvd, as Hexane @ 3% O ₂
FLARE OPERATING PARAMETERS					
Fuel Flow (scfm)	2,591	2,676	2,628	2,633	
Flare Temperature (°F)	1,412	1,382	1,394	1,396	
Inlet Methane (%)	48.43				
EUENCLOSEDFLARE1 - S2 (Flare392 (Zink) – 12/19/2019					
Run Times	1530-1630	1640-1740	1750-1850		
% O ₂	12.20	12.28	12.75	12.41	
Moisture (%)	8.6	8.7	7.8	8.4	
NOx lb/mmBtu	0.04	0.04	0.04	0.04	0.060 lb/mmBtu
CO lb/mmBtu	0.02	0.02	0.02	0.02	0.20 lb/mmBtu
NMOC as C ₃ H ₈ ppmvd	1.95	2.26	2.57	2.26	None
NMOC (ppmvd, as Hexane @ 3% O ₂)	1.32	1.55	1.86	1.58	20 ppmvd, as Hexane @ 3% O ₂
FLARE OPERATING PARAMETERS					
Fuel Flow (scfm)	3,494	3,378	3,317	3,396	
Flare Temperature (°F)	1,477	1,483	1,477	1,479	
Inlet Methane (%)	47.5				

The Compliance / Performance test was initiated on December 19, 2019 and concluded the same day.

Stratification within the stack was checked as defined by 40 CFR 60 and that data is presented **Appendix D**.

4.0 REFERENCE TEST EQUIPMENT AND PROCEDURES

4.1 Instrumentation and Equipment Procedures

Concentration measurements of NO_x, CO and O₂/CO₂ are made according to EPA Methods 3A, 7E and 10 using the analyzers listed in **Table 4.1-1**. **Figure 4.1-1** is a schematic of the wet/dry extractive reference measurement sampling system used by RMCEINC. All components of the sampling system that contact the sample are stainless steel, glass, or Teflon.

TABLE 4.1-1 Reference Method Analyzers

Parameter	Analyzer	Analytical Technique	Instrument Span
NO _x	Thermo Environmental Instruments (Model 42H)	Chemiluminescence	0 – 50/115 ppm
CO	Thermo Environmental Instruments (Model 48)	Gas Filter Correlation	0 – 30/100 ppm
NMOC	VIG Industries GC & VOC Analyzer	Flame Ionization	0-30 ppm
O ₂	Teledyne 3300/Servomex	Fuel Cell/Paramagnetic	0 – 21 %

RMCEINC used a standard manual probe sampling system. The manual sampling probe used a heated stainless-steel tubing and 3-way valve to provide a means of conducting the three-point stratification traverse and calibration checks. The probe assembly is constructed of Type 316 stainless steel and was heated electrically to maintain the sample temperature above the dew point of the stack gases or > 450^o F. A length of heated Teflon tubing, heated to over 450^o F, connects the probe to a moisture removal chiller. The condensed portion of the sample was routed to the wet / dry extractive system for distribution to the dry NO_x, CO, VOC and O₂/CO₂ analyzers. The uncondensed portion was routed to the VOC/GC analyzer.

RMCEINC conducted a leak test of the entire sampling system, including the probe, at the beginning of each test or at any time the test conditions indicate a leak has developed. At a minimum, the sampling system was leak-checked before and after the testing program (before the first run and after the last run). Results of the leak check is documented within the test report.

RMCEINC manually calibrated each analyzer by injecting the calibration gases directly into each gas analyzer and adjusting the response to match the reference gas value. Upon completing the calibration, RMCEINC conducted a "Calibration Error Check" (three-point check) by injecting the calibration gases directly into each gas analyzer and recording the responses on the reference data acquisition system for each of the three reference gases (zero, mid-range, and high-range). No adjustments were made to the analyzers after completing the initial calibration step.

RMCEINC conducted zero and upscale calibration checks (System Bias Checks) before and after each test run in order to quantify measurement system calibration drift and sampling system bias. Upscale is either the mid-range or high-range gas; whichever most closely approximates the flue gas level. During these checks, the calibration gases were introduced into the sampling system through a 3-way valve assembly at the probe outlet sample chamber so that the calibration gases are analyzed in the same manner as the flue gas samples.

RMCEINC recorded the reference analyzer measurements as both 1-minute and run averages on its DAS. All of pollutant test run averages determined from the gas concentrations measured during each test run were adjusted for bias and drift based on the zero and upscale sampling system bias test results (Equation 7E-1 presented in CFR, Title 40 Part 60, Method 7E, Section 8).

Prior to testing, RMCEINC also conducted a sample run with a 3-point traverse across the entire stack diameter of Flare 391 & 392. The sample traverse points used during this test project are included in the appendices to this report. For the third scenario, the traverse points were sampled for the first test run. The flare stacks demonstrated no stratification.

TABLE 4.1-2 STRATIFICATION TABLE

Source	Sampling Location	Diluent/Pollutant Tested	Maximum Deviation Difference, (ppm) or (%)
Enclosed Flare 391 – High Load	Outlet	NO _x O ₂	2.3 ppm 1.99 % - O ₂
Enclosed Flare 392 - Original Load	Outlet	NO _x O ₂	1.5 ppm 4.3 % - O ₂
Enclosed Flare 392 – High Load	Outlet	NO _x O ₂	0.2 ppm 1.16 % - O ₂
EPA Method Requirement	N/A	N/A	≤5 % or 5 ppm

FIGURE 4.1-1 Reference Method Gas Sampling System Diagram

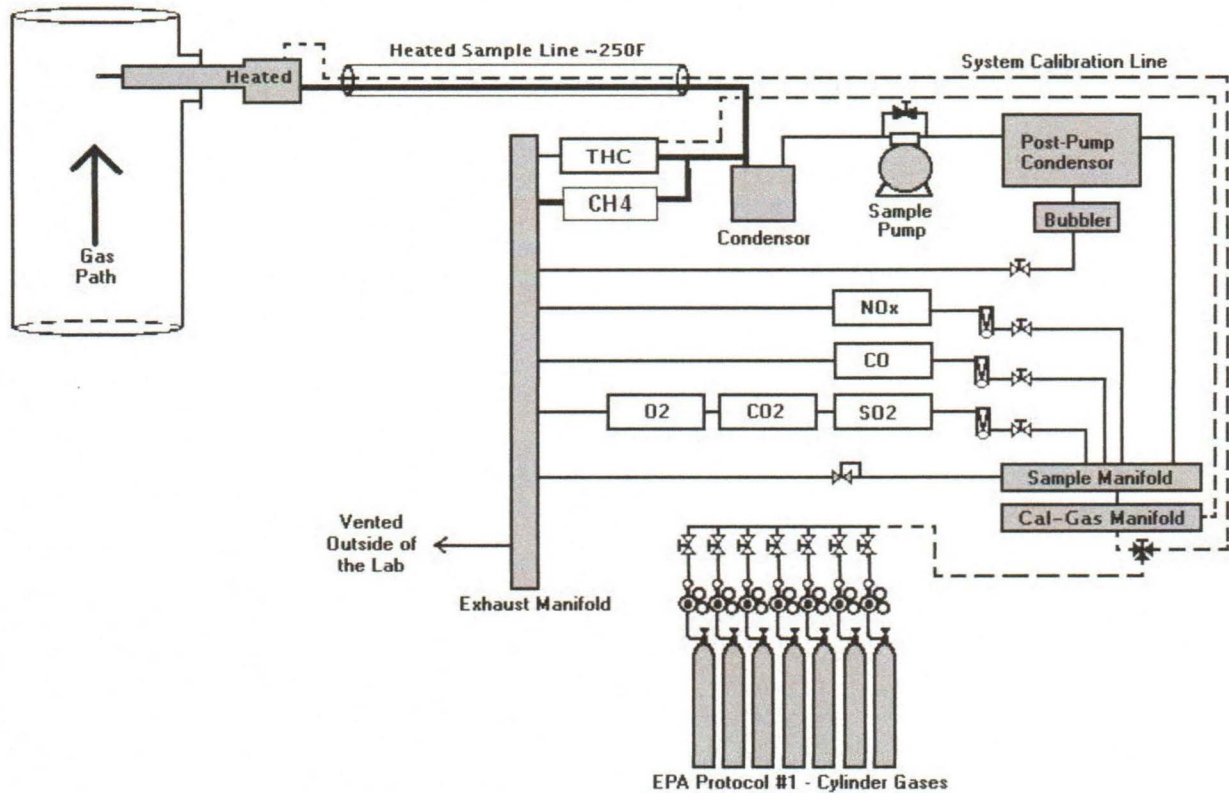

4.1.2 Performance Testing – NMOC

Concentration measurements of NMOC are made according to EPA Methods 25A/18 using the analyzers listed in **Table 4.1-1**. **Figure 4.1-1** is a schematic of the wet/dry extractive reference measurement sampling system used by RMCEINC. All components of the sampling system that contact the sample are stainless steel, glass, or Teflon.

Before the moisture removal system, a portion of the wet effluent was pulled off to serve the THC analyzer. This analyzer requires the sample to be unconditioned which allows for the full THC concentration in the sample to be analyzed., the sampling system was leak-checked before and after the testing program (before the first run and after the last run). Results of the leak check were documented within the project notes and available upon request.

In order to obtain NMOC (Non-Methane Organic Carbon) concentrations, an onsite GC was not employed, the VOC concentration was so low, the methane portion of the effluent was not subtracted from the total. The sensitivity of Method 25A is 2% of span, or approximately 0.6 ppm.

Gas bombs were collected for BTU Content and ultimate analysis. The results were used to calculate the emission rates.

4.1.3. Fuel Analysis Testing (EPA Method 19)

Gas bombs (small, Sulfinert®-coated, stainless steel pressure vessels) were collected and analyzed to determine heating value (btu/cf), methane, oxygen, carbon dioxide, nitrogen and sulfur content of the inlet LFG, and will be used to determine an F-Factor (dscf/MMBtu) for the site. The results were used to calculate the emission rate in lb/mmBtu. The F-Factor calculated from the landfill gas is presented in **Appendix E**.

4.2 Test Methods

Test methods used during the test project are described within the sections 4.1.1 – 4.1.3 above.

4.3 Analytical Methods

Analytical methods used during the test project are described within the sections 4.1.1 – 4.1.3 above.

4.4 Sampling Site Location

Section 2.1 above provides a detail description of the testing location. **Figure 2.1-1** provides a diagram of the Flare stack.

4.5 Sample Matrix

The sample matrix used during the test project is described within the sections 4.1.1 – 4.1.3 above.

5.0 QUALITY ASSURANCE AND EQUIPMENT CALIBRATION

RMCEINC followed the calibration and quality assurance procedures of EPA Methods 1, 3A, 4, 7E, 10, 19 and 25A throughout the test program. The maintenance for our meterboxes, probes, analyzers and other test equipment is performed off site by either Clean Air Engineering or Millenium Instruments. These companies ensure that our equipment is operating correctly and within the specification of the respective methods. All equipment is calibrated in accordance with the EPA Methods and guidelines.

The results of sampling system bias and calibration drift tests for each test run are calculated and presented in the test report. Cylinder gases used during the testing are certified to meet or exceed EPA Protocol 1 requirements. The meter box calibrations, pitot tube inspections, calibration gas certificates of analysis and the analyzer quality assurance checks are included in **Appendix D**.

RMCEINC uses computers throughout the test program. Spreadsheets and software programs are checked in our office for accuracy. Software used by RMCEINC is structured to eliminate human errors in data entry where possible by automating the process. When possible RMCEINC, inputs field data directly into the DAS system and eliminates the handwritten field data sheets. These systems provide an accurate measurement of the raw test data and are not used to modify or change test data in any manner. Equations used in these systems are taken directly from the CFR when possible and notations are provided if originated from an alternate source or customized in any manner.

The laboratory utilized for this test program is a NELAP Certified Laboratory. A copy of the chain of custody for this test program is included in **Appendix D**.

6.0 SOURCE TEST REPORT

6.1 Report Format

This final report follows the format defined within the protocol approved by the State of Michigan. All field data, calculations, and QA documentation are included within the appendices of this report.

6.2 Data Reduction Procedures/ Methods

In 1994 most of the data reduction (validation) was completed by hand and thus a written procedure was required in order to ensure that the data was handled and validated properly. Although some testing companies today still utilize this old method, RMCEINC utilizes an automated data reduction/validation procedure, thus eliminating the potential of errors that the old method was known. This automated system was developed in 1996 by a third party and has been continually verified each year though its use at several hundred test projects.

Figure 6.2-1 and 6.2-2 include several example calculations that were used during the test project. Example calculations of an actual test runs are included in **Appendix D**.

FIGURE 6.2-1 Example Calculations

EPA DUST LOADING FORMULAS

(1) ABSOLUTE FLUE PRESSURE (in. Hg)

$$P_s = (\pm P_f \div 13.6) + P_b$$

(2) WATER VAPOR VOLUME IN METERED GAS CORRECTED TO STANDARD CONDITIONS (scf)

$$V_{wc} = .04707 \times V_l \quad V_{wsg} = .04715 \times W_{sg}$$

$$V_w = V_{wc} + V_{wsg}$$

(3) METERED GAS VOLUME CORRECTED TO STANDARD CONDITIONS (scf)

$$V_{ms} = 17.64 \times Y \times V_m \frac{P_b + (\Delta H/13.6)}{T_m}$$

(4) PERCENT MOISTURE IN FLUE GAS

$$B_{ws} = \frac{V_w}{(V_{ms} + V_w)} \quad \%M = B_{ws} \times 100$$

(5) AVERAGE RESULTS OF FLUE GAS ANALYSIS

$$\%N_2 \text{ dry} = 100 - (\%CO_2 + \%O_2 + \%CO)$$

(6) APPROXIMATE MOLECULAR WEIGHT OF FLUE GAS (WET BASIS) (lb/lb-mole)

$$M_s = (18 \times B_{ws}) + \left((.440 (\%CO_2) + .320 (\%O_2) + .280 (\%N_2 + \%CO)) \times (1 - B_{ws}) \right)$$

(7) GAS VELOCITY IN FLUE (fps)

$$V_s = 85.49 \times C_p \times (\sqrt{\Delta P}) \text{ avg. } \sqrt{\frac{T_s}{P_s \times M_s}}$$

(8) FLUE GAS VOLUME AT ACTUAL CONDITIONS (acfm)

$$V_o = V_s \times A \times 60$$

(9) FLUE GAS VOLUME CORRECTED TO DRY STANDARD CONDITIONS (dscfh)

$$Q_{sd} = \frac{T_{std}}{29.92} \times \frac{P_s}{T_s} \times V_o \times (1 - B_{ws}) \times 60$$

(10) TOTAL FLUE GAS VOLUME SAMPLED AT ACTUAL CONDITIONS (acf)

$$V_t = \left[V_m \times Y \times \frac{T_s}{T_m} \times \left(\frac{P_b + (\Delta H/13.6)}{P_s} \right) \right] + \left(0.00267 \times V_{lc} \times \frac{T_s}{P_s} \right)$$

030281 Form AQD-(T-S)-1N
Page 2 of 3

FIGURE 6.2-1 Example Calculations (Continued)

NOMENCLATURE	
acf	= actual cubic feet
acfm	= actual cubic feet per minute
A	= effective area of flue in square feet
acm	= actual cubic meters
acmm	= actual cubic meters per minute
A_n	= inside area of sampling nozzle in square feet
B_{ws}	= water vapor in gas stream, proportion by volume
%C	= percent carbon by weight, dry basis
%CO	= percent carbon monoxide by volume, dry basis
%CO ₂	= percent carbon dioxide by volume, dry basis
C_p	= pitot tube coefficient
D_l	= dust loading per heat input in pounds (grams) per million Btu (calories) per Fr constant
D_l'	= dust loading per heat input in pounds (grams) per million Btu (calories) per Fr calculated
dscf	= dry standard cubic feet
dscfh	= dry standard cubic feet per hour
dscm	= dry standard cubic meters
dscmh	= dry standard cubic meters per hour
fps	= feet per second
F_r	= ratio factor of dry flue gas volume to heat value of combusted fuel in dry standard cubic feet (meters) per million Btu (calories)
gms	= grams
gm-mole	= gram-mole
grs	= grains
ΔH	= orifice pressure drop in inches water, average
%H	= percent hydrogen by weight, dry basis
H_c	= heat of combustion in Btu per pound, dry basis
hr	= hour
%I	= percent isokinetic
in. Hg	= inches mercury
lbs	= pounds
lb-mole	= pound-mole
%M	= percent moisture by volume
mmBtu	= million Btu
mmcal	= million calories
mm Hg	= millimeters mercury
mps	= meters per second
M_s	= molecular weight in pound (gram) per pound (gram) mole (wet basis)
%N	= percent nitrogen by weight, dry basis
%N ₂	= percent nitrogen by difference, dry basis
%O	= percent oxygen by difference, dry basis
%O ₂	= percent oxygen by volume, dry basis
P_b	= barometric pressure in inches mercury
P_{std}	= standard absolute pressure (29.92 in Hg)
P_s	= absolute pressure in flue in inches (millimeters) mercury
P_f	= static pressure in flue in inches water, average
$\sqrt{\Delta P}$	= square root of velocity head in inches water, average
%S	= percent sulfur by weight, dry basis
scf	= standard cubic feet
scm	= standard cubic meters
T_{std}	= absolute temperature of air in degrees Rankine at standard conditions (528 degrees)
T_s	= absolute temperature of flue gas in degrees Rankine, average
T_m	= absolute temperature at meter in degrees Rankine, average
V_s	= velocity of flue gas in feet (meters) per second
V_l	= volume of condensate through the impingers in milliliters
V_{lc}	= volume of liquid collected in condenser in milliliters plus weight of liquid absorbed in silica gel in grams indicated as milliliters
V_m	= volume of metered gas measured at meter conditions in cubic feet
V_{ms}	= volume of metered gas corrected to dry standard conditions in cubic feet (meters)
V_o	= volume of flue gas at actual conditions in cubic feet (meters) per minute
Q_{sd}	= volume of flue gas corrected to dry standard conditions in cubic feet (meters) per hour
V_t	= total volume of flue gas sampled at actual conditions in cubic feet (meters)
V_w	= volume of water vapor in metered gas corrected to standard conditions in cubic feet (meters)
V_{wc}	= volume of water condensed in impingers corrected to standard conditions
V_{wsg}	= volume of water collected in silica gel corrected to standard conditions
W_a	= total weight of dust collected per unit volume in grains (grams) per actual cubic feet (meters)
W_d	= total weight of dust collected per unit volume in pounds (grams) per dry standard cubic feet (meters)
W_g	= total weight of dust collected in grams
W_h	= total weight of dust collected per unit volume in pounds (grams) per hour, dry basis
W_p	= total weight of dust collected in pounds
W_s	= total weight of dust collected per unit volume in grains (grams) per dry standard cubic feet (meters)
W_{sg}	= impinger silica gel weight gain in grams
Y	= metered gas volume correction factor
Θ	= total elapsed sampling time in minutes

030281



Form AQD-(T-S)-1N
Page 1 of 3