

## 1.0 Introduction

### 1.1 Summary of Test Program

Bay City Electric, Light and Power (BCELP) contracted Montrose Air Quality Services, LLC (Montrose) to perform a compliance test program on the Dual Fuel Diesel Engines (EUENGINE1 and EUENGINE2) at the BCELP-Water Street Station (State Registration No. (SRN) B7529) and Dual Fuel Diesel Engines (EU00001 and EU00002) at the BCELP-Henry Street Station (SRN N3195) both located in Bay City, Michigan. Testing was performed on May 10 and 12, 2022 at the BCELP-Water Street Station for the purpose of satisfying the emission testing requirements pursuant to Michigan Department of Environment, Great Lakes, and Energy (EGLE) Permit-to-Install (PTI) No. 587-96A and 40 CFR, Part 63, Subpart ZZZZ and on May 11, 2022 at the Henry Street Station, for the purpose of satisfying the emission testing requirements pursuant to EGLE PTI No. 823-19B and 40 CFR, Part 63, Subpart ZZZZ.

The specific objectives were to:

- Verify the emissions (lb/MMBtu) of carbon monoxide (CO) from the Catalytic Oxidizer (CAT-OX) serving EUENGINE1 and EUENGINE2 (FGENGINES)
- Determine the CO ppmvd corrected to 15% (CO ppmvd @ 15% O<sub>2</sub>) destruction efficiency (DE) of the CAT-OX serving FGENGINES
- Verify the emissions (lb/MMBtu) of CO from the CAT-OX serving EU00001 and EU00002 (FG00001)
- Determine the CO ppmvd @ 15% O<sub>2</sub> DE of the CAT-OX serving FG00001
- Conduct the test program with a focus on safety

Montrose performed the tests to measure the emission parameters listed in Table 1-1.

**Table 1-1**  
**Summary of Test Program**

Test Dates	Unit ID/ Source Name	Activity/Parameters	Test Methods	No. of Runs	Duration (Minutes)
5/10/2022	EUENGINE1	O <sub>2</sub>	EPA 3A	3	62
5/10/2022	EUENGINE1	CO	EPA 10	3	62
5/11/2022	EU00001	O <sub>2</sub>	EPA 3A	3	62
5/11/2022	EU00001	CO	EPA 10	3	62
5/11/2022	EU00002	O <sub>2</sub>	EPA 3A	3	60
5/11/2022	EU00002	CO	EPA 10	3	60

Test Dates	Unit ID/ Source Name	Activity/Parameters	Test Methods	No. of Runs	Duration (Minutes)
5/12/2022	EUENGINE2	O <sub>2</sub>	EPA 3A	3	60
5/12/2022	EUENGINE2	CO	EPA 10	3	60

To simplify this report, a list of Units and Abbreviations is included in Appendix C.1. Throughout this report, chemical nomenclature, acronyms, and reporting units are not defined. Please refer to the list for specific details.

This report presents the test results and supporting data, descriptions of the testing procedures, descriptions of the Station and sampling locations, and a summary of the quality assurance procedures used by Montrose. The average emission test results are summarized and compared to their respective permit limits in Tables 1-2 and 1-3. Detailed results for individual test runs can be found in Section 4.0. All supporting data can be found in the appendices.

The testing was conducted by Montrose personnel listed in Table 1-4. The tests were conducted according to the test plan (protocol) dated March 29, 2022 that was submitted to the EGLE.

**Table 1-2**  
**Summary of Average Compliance Results – FGENGINE5**  
**May 10\* and 12\*\*, 2022**

Parameter/Units	Average Results		Emission Limits
	EUENGINE1*	EUENGINE2**	
<b>Carbon Monoxide (CO)</b>			
lb/MMBtu	0.072	0.099	--
<b>CO ppmvd at 15% O<sub>2</sub> Destruction Efficiency (DE)</b>			
%	86	85	70

**Table 1-3**  
**Summary of Average Compliance Results – FG00001**  
**May 11, 2022**

Parameter/Units	Average Results		Emission Limits
	EUE00001	EU00002	
<b>Carbon Monoxide (CO)</b>			
lb/MMBtu	0.064	0.068	--
<b>CO ppmvd at 15% O<sub>2</sub> DE</b>			
%	85	86	

**RECEIVED**

JUL 13 2022

## 1.2 Key Personnel

A list of project participants is included below:

### Facility Information

Source Location: BCEL P-Water Street Station  
900 South Water Street  
Bay City, MI 48708

Source Location: BCEL P-Henry Street Station  
617 S Henry St.  
Bay City, MI 48706

Project Contact: Neil Samyn  
Role: Generation and Maintenance Supervisor  
Company: BCEL P  
Telephone: 989-894-8350

### Agency Information

Regulatory Agency: Michigan Department of Environment, Great Lakes, and Energy

Agency Contact: Trevor Drost	Kathy Brewer
Telephone: 517-245-5781	989-439-2100
Email: drostt@michigan.gov	BrewerK@Michigan.gov

### Testing Company Information

Testing Firm: Montrose Air Quality Services, LLC	
Contact: John Nestor	Todd Wessel
Title: District Manager	Client Project Manager
Telephone: 248-548-8070	248-548-8070
Email: jonestor@montrose-env.com	twessel@montrose-env.com

### Consultant Information

Company: NTH Consultants, Ltd.  
Contact: Chloe Palajac  
Telephone: 313-600-1191  
Email: cpalajac@nthconsultants.com

Test personnel and observers are summarized in Table 1-4.

**Table 1-4  
Test Personnel and Observers**

<b>Name</b>	<b>Affiliation</b>	<b>Role/Responsibility</b>
Todd Wessel	Montrose	Client Project Manager
David Koponen	Montrose	Field Technician
Neil Samyn	BCELP	Observer/Client Liaison/Test Coordinator
Chloe Palajac	NTH Consultants, Ltd.	Observer
Kathy Brewer	EGLE	Observer
Trevor Drost	EGLE	Observer
Daniel Droste	EGLE	Observer

## 2.0 Plant and Sampling Location Descriptions

### 2.1 Process Description, Operation, and Control Equipment

The Water and Henry Street facilities each operate two dual fuel diesel engine/generators. Dual fuel is approximately 95% natural gas and 5% diesel. At the Water Street facility EUENGINE1 is rated at 5,757 kW (8000 hp) and EUENGINE2 is rated at 6,955 kW (9630 hp). The Henry Street facility operates EU00001 and EU00002 both rated at 7,750 kW. All engines were in operation during this test event.

### 2.2 Flue Gas Sampling Locations

Information regarding the sampling locations is presented in Table 2-1.

**Table 2-1**  
**Sampling Locations**

Sampling Location	Stack Inside Diameter (in.)	Distance from Nearest Disturbance		Number of Traverse Points
		Downstream EPA "B" (in./dia.)	Upstream EPA "A" (in./dia.)	
EUENGINE1 CAT-OX Inlet Duct	24	≥48.0/≥2.0	≥12.0/≥0.5	Gaseous: 6
EUENGINE1 CAT-OX Exhaust Stack	28	≥56.0/≥2.0	≥14.0/≥0.5	Gaseous: 12 (6/port)
EUENGINE2 CAT-OX Inlet Duct	24	≥48.0/≥2.0	≥12.0/≥0.5	Gaseous: 6
EUENGINE2 CAT-OX Exhaust Stack	30	≥60.0/≥2.0	≥15.0/≥0.5	Gaseous: 12 (6/port)
EU00001 CAT-OX Inlet Duct	24	100.0/4.2	100.0/4.2	Gaseous: 6
EU00001 CAT-OX Exhaust Stack	48	480.0/10.0	120.0/2.5	Gaseous: 12 (6/port)
EU00002 CAT-OX Inlet Duct	24	100/4.2	100/4.2	Gaseous: 6
EU00002 CAT-OX Exhaust	34	480.0/10.0	120.0/2.5	Gaseous: 12 (6/port)

**RECEIVED**

The sample locations utilize historical Method 1 traverse points See Appendix A.1 for more information.

## 2.3 Operating Conditions and Process Data

Emission tests were performed while the engines and CAT-OXs were operating at the conditions required by the permit. The units were tested when operating normally.

Plant personnel were responsible for establishing the test conditions and collecting all applicable unit-operating data. The process data that was provided is presented in Appendix B. Data collected includes the following parameters:

- Engine Load, KW
- Catalyst Temperature, °F
- Catalyst Differential Pressure, in-H<sub>2</sub>O (x10)
- Diesel Fuel Usage, gallons
- Natural Gas Usage, MCF
- Engine Run Duration, hr
- Engine Run Duration while burning Dual Fuel, hr
- Diesel Burn Rate, gal/hr
- Natural Gas Burn Rate, MCF/hr

## **3.0 Sampling and Analytical Procedures**

### **3.1 Test Methods**

The test methods for this test program have been presented in Table 1-1. Additional information regarding specific applications or modifications to standard procedures is presented below.

#### **3.1.1 EPA Method 3A, Determination of Oxygen and Carbon Dioxide Concentrations in Emissions from Stationary Sources (Instrumental Analyzer Procedure)**

EPA Method 3A is an instrumental test method used to measure the concentration of O<sub>2</sub> and CO<sub>2</sub> in stack gas. The effluent gas is continuously or intermittently sampled and conveyed to analyzers that measure the concentration of O<sub>2</sub> and CO<sub>2</sub>. The performance requirements of the method must be met to validate data.

The typical sampling system is detailed in Figure 3-1 (EPA Method 3A and 10 Sampling Train).

#### **3.1.2 EPA Method 10, Determination of Carbon Monoxide Emissions from Stationary Sources (Instrumental Analyzer Procedure)**

EPA Method 10 is an instrumental test method used to continuously measure emissions of CO. Conditioned gas is sent to an analyzer to measure the concentration of CO. The performance requirements of the method must be met to validate the data.

The typical sampling system is detailed in Figure 3-1 (EPA Method 3A and 10 Sampling Train).

#### **3.1.3 EPA Method 19, Determination of Sulfur Dioxide Removal Efficiency and Particulate Matter, Sulfur Dioxide, and Nitrogen Oxide Emission Rates**

EPA Method 19 is used to calculate mass emission rates in units of lb/MMBtu. EPA Method 19, Table 19-2 contains a list of assigned fuel factors for different types of fuels, which can be used for these calculations.



**Figure 3-1**  
**EPA Methods 3A and 10 Sampling Train**

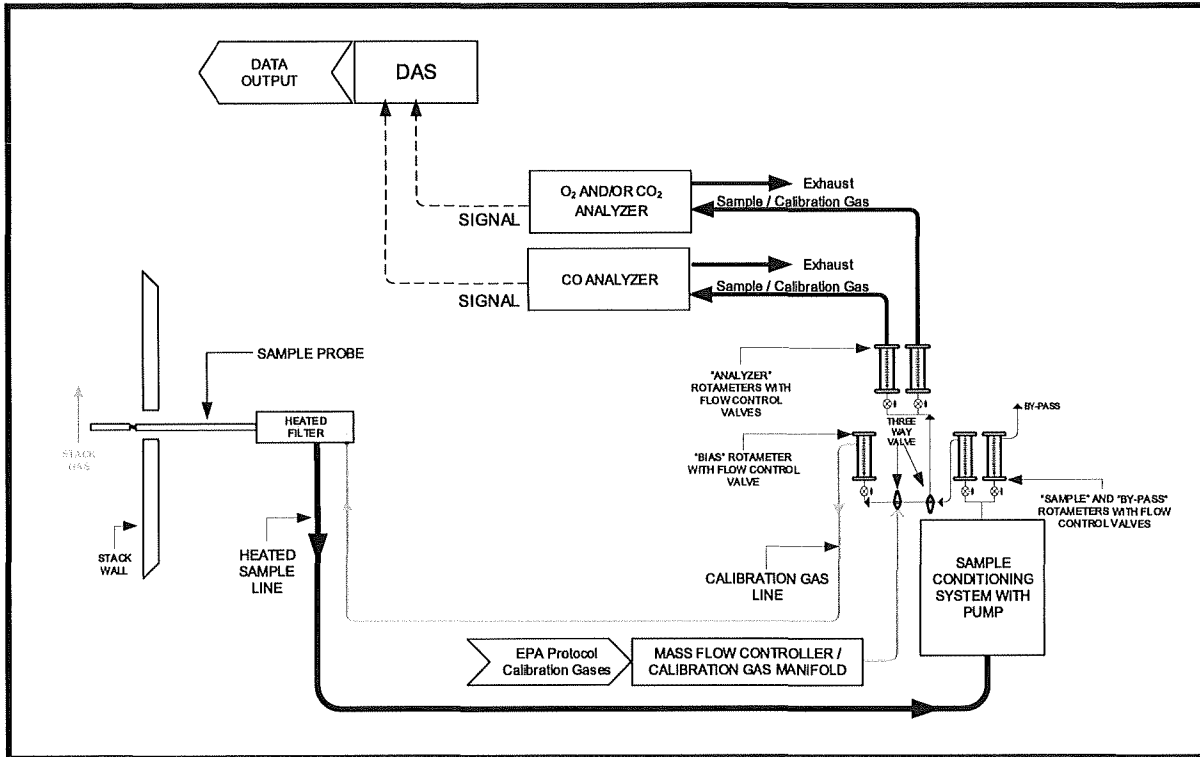

### 3.2 Process Test Methods

The test plan did not require that process samples be collected during this test program; therefore, no process sample data are presented in this test report.



## 4.0 Test Discussion and Results

### 4.1 Field Test Deviations and Exceptions

Testing at EUENGINE2 on May 10, 2022 was aborted because temperature of the unit was not within parameters to run on natural gas. As a result, testing on EUENGINE2 was postponed to May 12, 2022.

### 4.2 Presentation of Results

The average results are compared to the permit limits in Tables 1-2 and 1-3. The results of individual compliance test runs performed are presented in Tables 4-1 through 4-8. Emissions are reported in units consistent with those in the applicable regulations or requirements. Additional information is included in the appendices as presented in the Table of Contents.

The F-Factors for Combined Fuels for each engine was derived utilizing fuel usage rates and heating values for natural gas and diesel fuel provided by the facility.

During this compliance test program dual fuel usage was approximately 90% natural gas and 10% diesel fuel at the Water Street facility and 93% natural gas and 7% diesel fuel at the Henry Street facility.

**Table 4-1  
CO Emissions Results -  
EUENGINE1 CAT-OX Inlet Duct**

Parameter/Units	Run 1	Run 2	Run 3	Average
Date	5/10/2022	5/10/2022	5/10/2022	--
Time	10:26-11:35	12:01-13:07	13:30-14:38	--
<b>Sampling &amp; Flue Gas Parameters</b>				
O <sub>2</sub> , % volume dry	11.47	11.44	11.37	11.43
<b>Carbon Monoxide (CO)</b>				
ppmvd	349.4	377.0	384.4	370.3
ppmvd @ 15% O <sub>2</sub>	218.6	235.2	237.9	230.6

**Table 4-2  
CO Emissions and DE Results -  
EUENGINE1 CAT-OX Exhaust Stack**

Parameter/Units	Run 1	Run 2	Run 3	Average
Date	5/10/2022	5/10/2022	5/10/2022	--
Time	10:26-11:35	12:01-13:07	13:30-14:38	--
<b>Process Data*</b>				
Natural Gas Usage, MMBtu/hr	47.20	47.20	47.20	47.20
Diesel Fuel Usage, MMBtu/hr	5.86	5.86	5.86	5.86
Combined Fd, dscf/MMBtu	8,763	8,763	8,763	8,763
<b>Sampling &amp; Flue Gas Parameters</b>				
O <sub>2</sub> , % volume dry	11.39	11.73	11.30	11.47
<b>Carbon Monoxide (CO)</b>				
ppmvd	50.1	51.0	53.0	51.4
ppmvd @ 15% O <sub>2</sub>	31.0	32.8	32.6	32.1
lb/MMBtu	0.070	0.074	0.073	0.072
<b>CO ppmvd @ 15% O<sub>2</sub> Destruction Efficiency (DE)</b>				
%	85.8	86.1	86.3	86.1

\* Process Data was provided by BCEL facility personnel. See Section 4.2 for details.

**Table 4-3  
CO Emissions Results -  
EUENGINE2 CAT-OX Inlet Duct**

Parameter/Units	Run 1	Run 2	Run 3	Average
Date	5/12/2022	5/12/2022	5/12/2022	--
Time	8:10-9:16	9:37-10:42	11:03-12:08	--
<b>Sampling &amp; Flue Gas Parameters</b>				
O <sub>2</sub> , % volume dry	12.37	12.39	12.32	12.36
<b>Carbon Monoxide (CO)</b>				
ppmvd	442.3	434.8	401.0	426.0
ppmvd @ 15% O <sub>2</sub>	306.0	301.5	275.6	294.4

**Table 4-4  
CO Emissions and DE Results -  
EUENGINE2 CAT-OX Exhaust Stack**

Parameter/Units	Run 1	Run 2	Run 3	Average
Date	5/12/2022	5/12/2022	5/12/2022	--
Time	8:10-9:16	9:37-10:42	11:03-12:08	--
<b>Process Data*</b>				
Natural Gas Usage, MMBtu/hr	59.39	59.39	59.39	59.39
Diesel Fuel Usage, MMBtu/hr	5.20	5.20	5.20	5.20
Combined Fd, dscf/MMBtu	8,749	8,749	8,749	8,749
<b>Sampling &amp; Flue Gas Parameters</b>				
O <sub>2</sub> , % volume dry	12.35	12.79	12.24	12.46
<b>Carbon Monoxide (CO)</b>				
ppmvd	65.4	62.3	62.3	63.3
ppmvd @ 15% O <sub>2</sub>	45.1	45.3	42.5	44.3
lb/MMBtu	0.101	0.102	0.095	0.099
<b>CO ppmvd @ 15% O<sub>2</sub> Destruction Efficiency (DE)</b>				
%	85.2	85.0	84.6	84.9

\* Process Data was provided by BCELFP facility personnel. See Section 4.2 for details.

RECEIVED

JUL 13 2022

AIR QUALITY DIVISION

**Table 4-5**  
**CO Emissions Results -**  
**EU00001 CAT-OX Inlet Duct**

Parameter/Units	Run 1	Run 2	Run 3	Average
Date	5/11/2022	5/11/2022	5/11/2022	--
Time	8:30-9:38	10:00-11:08	11:30-12:38	--
<b>Sampling &amp; Flue Gas Parameters</b>				
O <sub>2</sub> , % volume dry	11.41	11.51	11.46	11.46
<b>Carbon Monoxide (CO)</b>				
ppmvd	289.98	289.71	351.54	310.41
ppmvd @ 15% O <sub>2</sub>	180.25	181.96	219.71	193.97

**Table 4-6**  
**CO Emissions and DE Results -**  
**EU00001 CAT-OX Exhaust Stack**

Parameter/Units	Run 1	Run 2	Run 3	Average
Date	5/11/2022	5/11/2022	5/11/2022	--
Time	8:30-9:38	10:00-11:08	11:30-12:38	--
<b>Process Data*</b>				
Natural Gas Usage, MMBtu/hr	71.40	71.4	71.4	71.4
Diesel Fuel Usage, MMBtu/hr	5.36	5.36	5.36	5.36
Combined Fd, dscf/MMBtu	8,744	8,744	8,744	8,744
<b>Sampling &amp; Flue Gas Parameters</b>				
O <sub>2</sub> , % volume dry	11.38	11.92	11.45	11.58
<b>Carbon Monoxide (CO)</b>				
ppmvd	46.69	44.55	44.09	45.11
ppmvd @ 15% O <sub>2</sub>	28.93	29.28	27.53	28.58
lb/MMBtu	0.065	0.066	0.062	0.064
<b>CO ppmvd @ 15% O<sub>2</sub> Destruction Efficiency (DE)</b>				
%	83.9	83.9	87.5	85.1

\* Process Data was provided by BCEL facility personnel. See Section 4.2 for details.

**Table 4-7**  
**CO Emissions Results -**  
**EU00002 CAT-OX Inlet Duct**

Parameter/Units	Run 1	Run 2	Run 3	Average
Date	5/11/2022	5/11/2022	5/11/2022	--
Time	13:00-14:11	14:35-15:42	16:12-17:18	--
<b>Sampling &amp; Flue Gas Parameters</b>				
O <sub>2</sub> , % volume dry	11.46	11.52	11.53	11.50
<b>Carbon Monoxide (CO)</b>				
ppmvd	311.34	370.12	335.96	339.14
ppmvd @ 15% O <sub>2</sub>	194.62	232.79	211.45	212.95

**Table 4-8**  
**CO Emissions and DE Results -**  
**EU00002 CAT-OX Exhaust Stack**

Parameter/Units	Run 1	Run 2	Run 3	Average
Date	5/11/2022	5/11/2022	5/11/2022	--
Time	13:00-14:11	14:35-15:42	16:12-17:18	--
<b>Process Data*</b>				
Natural Gas Usage, MMBtu/hr	68.0	68.0	68.0	68.0
Diesel Fuel Usage, MMBtu/hr	5.25	5.25	5.25	5.25
Combined Fd, dscf/MMBtu	8,744	8,744	8,744	8,744
<b>Sampling &amp; Flue Gas Parameters</b>				
O <sub>2</sub> , % volume dry	11.91	11.48	11.94	11.78
<b>Carbon Monoxide (CO)</b>				
ppmvd	46.3	47.5	46.5	46.8
ppmvd @ 15% O <sub>2</sub>	30.4	29.7	30.7	30.267
lb/MMBtu	0.068	0.067	0.069	0.068
<b>CO ppmvd @ 15% O<sub>2</sub> Destruction Efficiency (DE)</b>				
%	84.4	87.2	85.5	85.7

\* Process Data was provided by BCELFP facility personnel. See Section 4.2 for details.

## **5.0 Internal QA/QC Activities**

### **5.1 QA/QC Audits**

EPA Method 3A and 10 calibration audits were all within the measurement system performance specifications for the calibration drift checks, system calibration bias checks, and calibration error checks.

### **5.3 Quality Statement**

Montrose is qualified to conduct this test program and has established a quality management system that led to accreditation with ASTM Standard D7036-04 (Standard Practice for Competence of Air Emission Testing Bodies). Montrose participates in annual functional assessments for conformance with D7036-04 which are conducted by the American Association for Laboratory Accreditation (A2LA). All testing performed by Montrose is supervised on site by at least one Qualified Individual (QI) as defined in D7036-04 Section 8.3.2. Data quality objectives for estimating measurement uncertainty within the documented limits in the test methods are met by using approved test protocols for each project as defined in D7036-04 Sections 7.2.1 and 12.10. Additional quality assurance information is included in the report appendices. The content of this report is modeled after the EPA Emission Measurement Center Guideline Document (GD-043).



**MONTROSE**  
AIR QUALITY SERVICES

## **Appendix A**

### **Field Data and Calculations**



## **Appendix A.1**

# **Sampling Locations**

### EUENGINE 1 AND 2 SAMPLING LOCATION SCHEMATIC

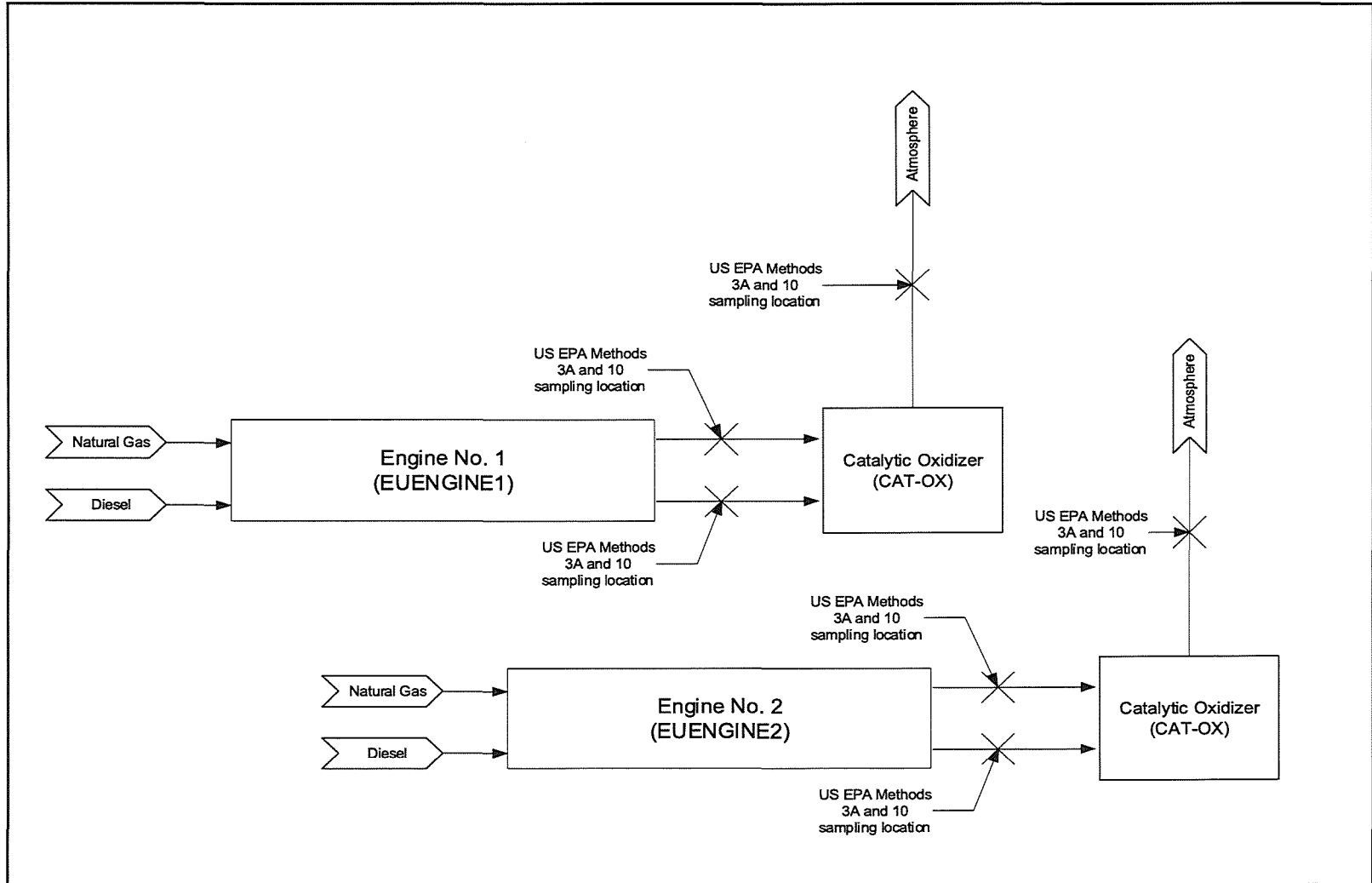

**EUENGINE1/EUENGINE CAT-OX INLET DUCT TRAVERSE POINT LOCATION DRAWING**

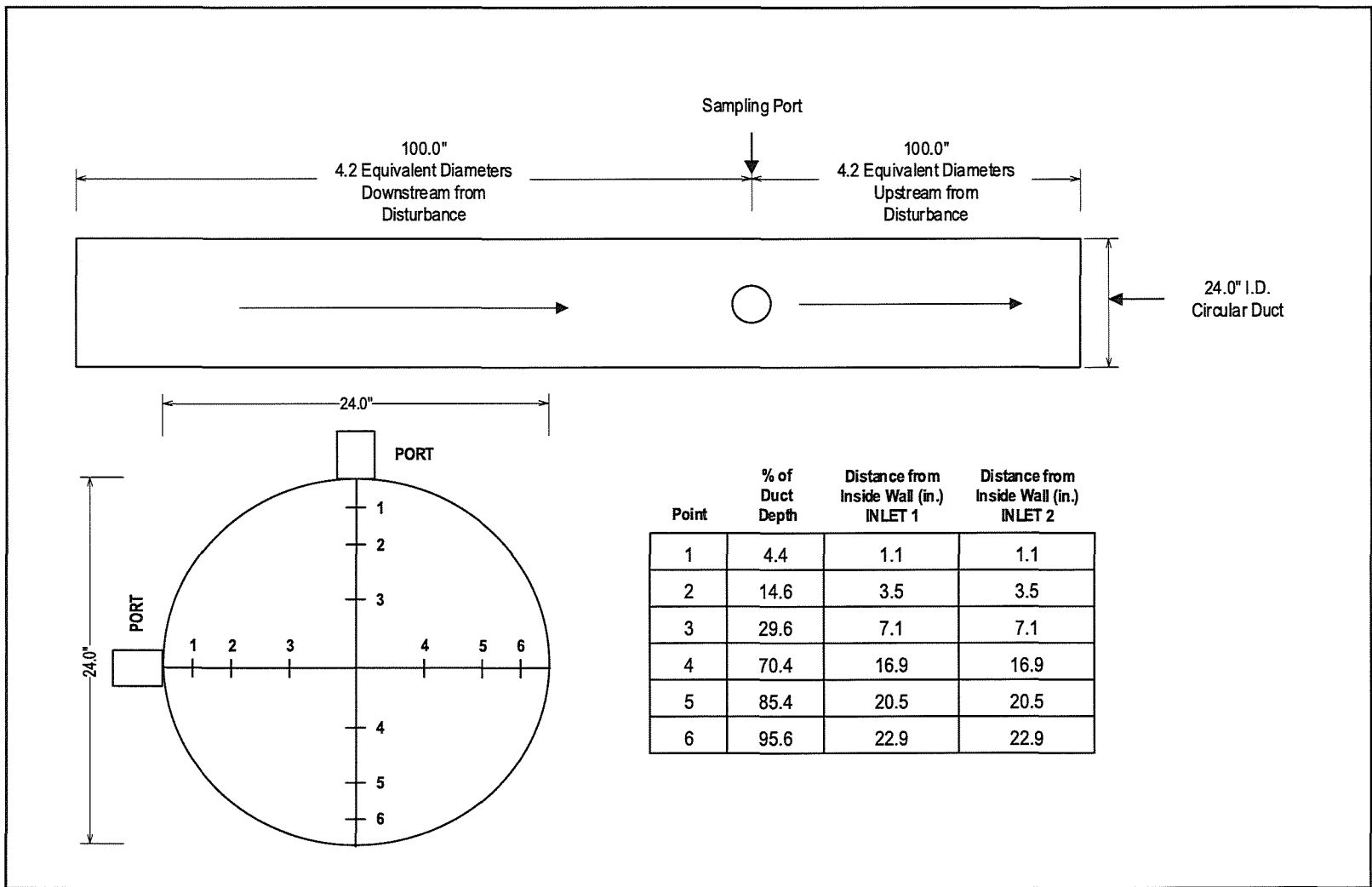

**EUENGINE1/2 CAT-OX EXHAUST STACK TRAVERSE POINT LOCATION DRAWING**

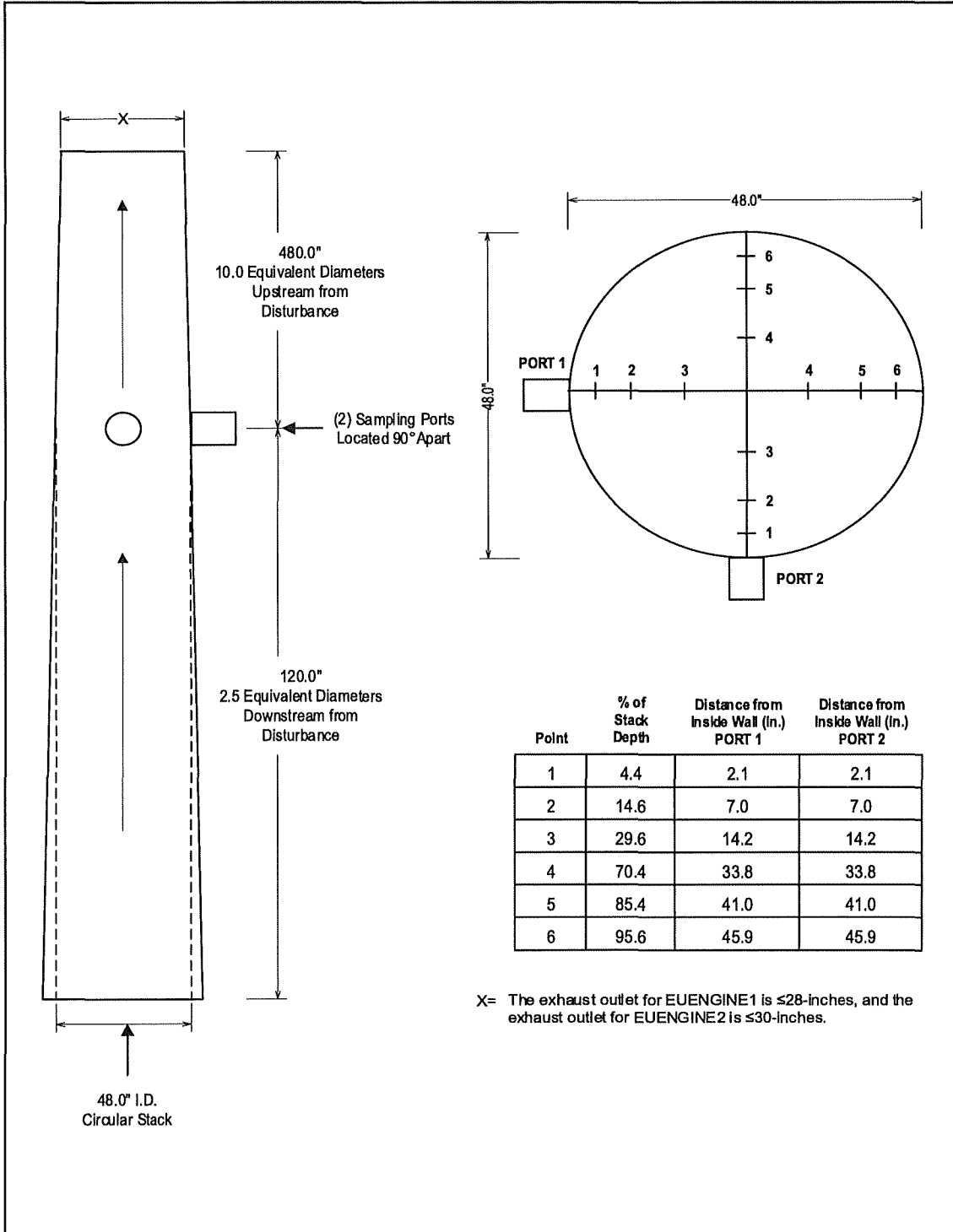

### EU00001 AND 2 SAMPLING LOCATION SCHEMATIC

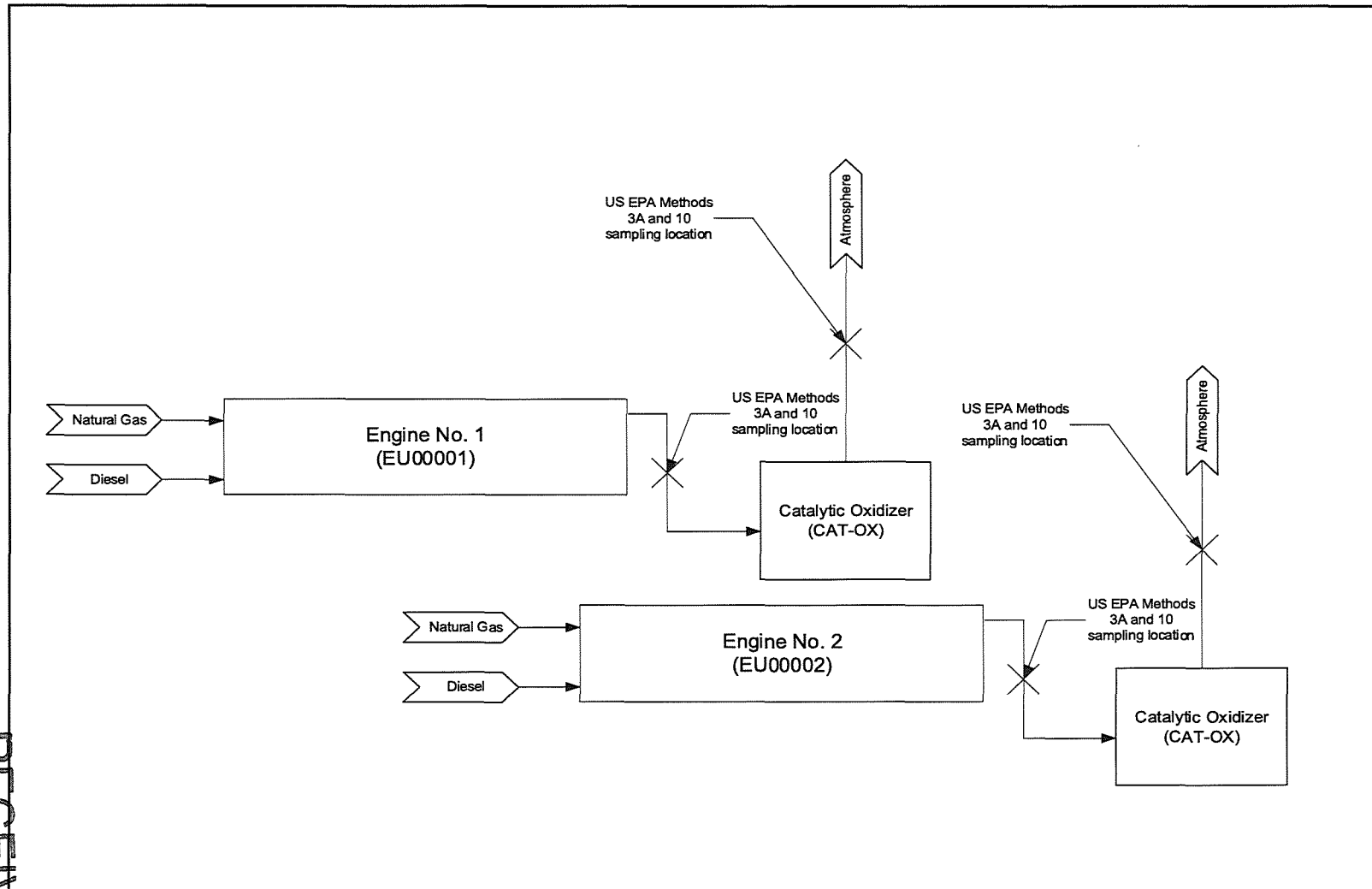

AIR QUALITY DIVISION

JUL 13 2022

RECEIVED

**EU00001/2 CAT-OX INLET DUCT TRAVERSE POINT LOCATION DRAWING**

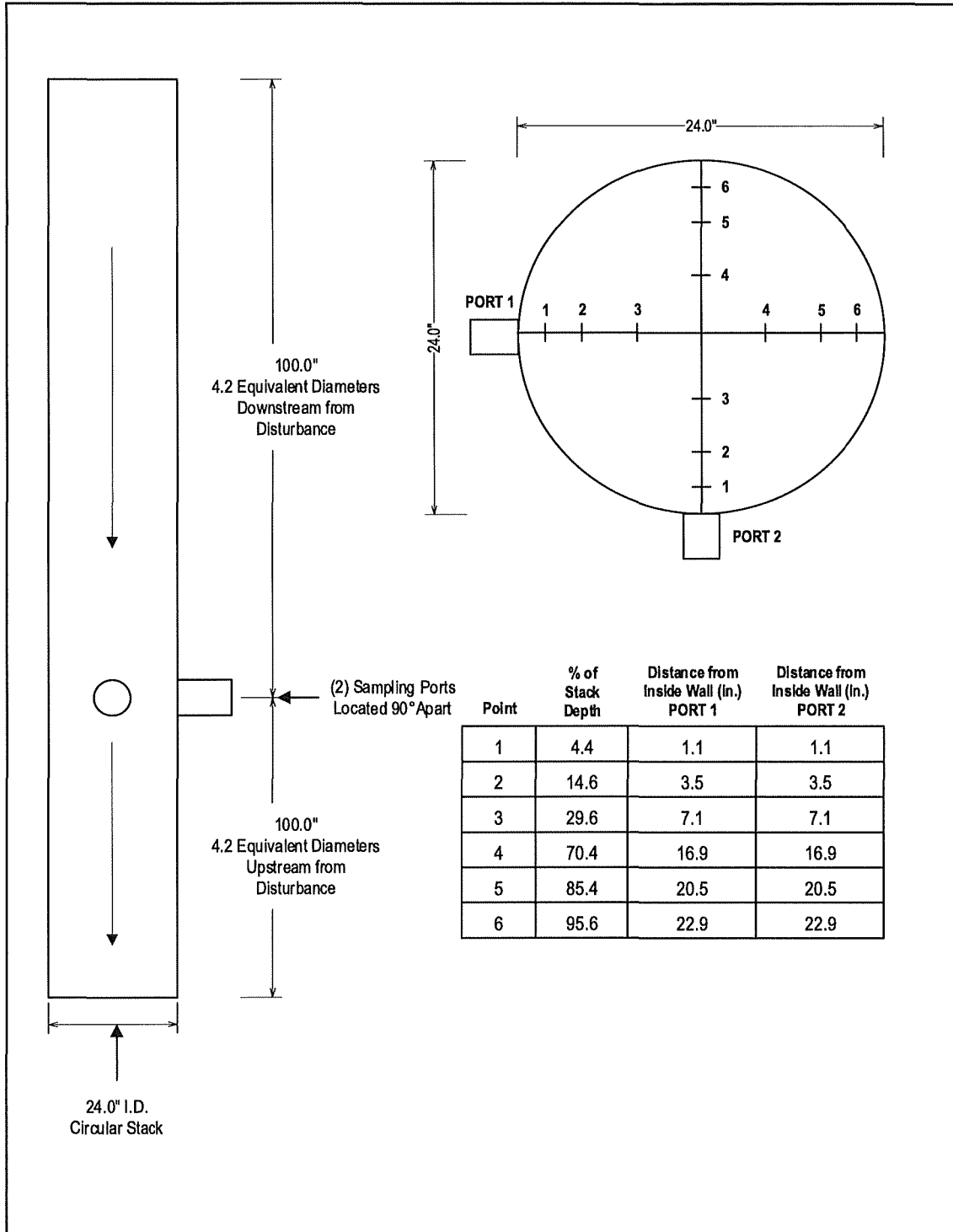

**EU00001 CAT-OX EXHAUST TRAVERSE POINT LOCATION DRAWING**

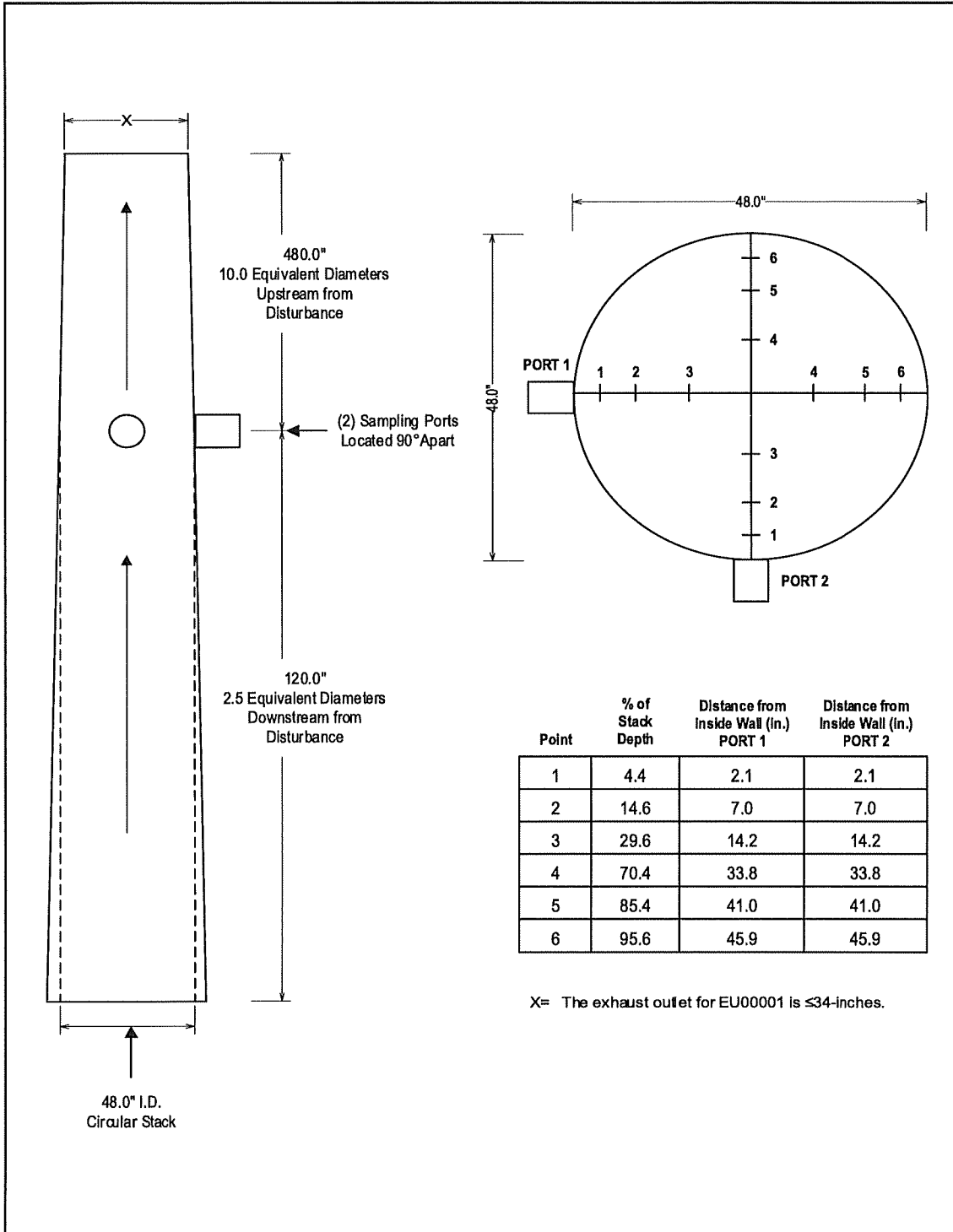



**EU00002 CAT-OX EXHAUST TRAVERSE POINT LOCATION DRAWING**

