

1.0 Introduction

1.1 Summary of Test Program

Genesee Power Station L.P. (State Registration No.: N3570) contracted Montrose Air Quality Services, LLC (Montrose) to perform the Annual Quality Assurance (QA) Relative Accuracy Test Audit (RATA) for the Continuous Emission Monitoring Systems (CEMS) associated with the Wood Biomass Boiler (EU-BOILER) at the Genesee Power Station L.P. facility located in Flint, Michigan. Testing was performed on September 21, 2022, and September 23, 2022, for the purpose of satisfying the emission testing requirements pursuant to Michigan Department of Environment, Great Lakes, and Energy (EGLE) Renewable Operation Permit No. MI-ROP-N3570-2018, 40 CFR Part 97, and 40 CFR Part 63, Subpart DDDDD by evaluating the quality of the emissions data produced by Genesee Power Station L.P.'s CEMS in accordance with 40 CFR Part 60, Appendices B and F, and 40 CFR Part 75, Appendices A and B.

1.1.1 Part 75 RATA

For the Part 75 RATA, the specific objectives were to:

- Verify the relative accuracy (RA) of the EU-BOILER CEMS for nitrogen oxides (NO_x) concentration (ppmvd), sulfur dioxide (SO₂) concentration (ppmvd), oxygen (O₂) concentration (%-Dry) and volumetric flow rate (scfh) during Low (Normal) Load (<50% of maximum rated capacity) conditions in accordance with Performance Specifications 2 (PS-2), 3 (PS-3), 4 (PS-4), and 6 (PS-6)
- Verify the relative accuracy (RA) of the EU-BOILER CEMS for the volumetric flow rate (scfh) during High Load (>80% of maximum rated capacity) conditions in accordance with PS-6
- Conduct the test program with a focus on safety

1.1.2 Part 60 RATA

For the Part 60 RATA, the specific objectives were to:

- Verify the relative accuracy (RA) of the EU-BOILER CEMS for NO_x emissions (lb/MMBtu) (as NO₂), carbon monoxide (CO) emissions (lb/MMBtu), and CO concentration (ppmvd corrected to 3% O₂) during Low (Normal) Load (<50% of maximum rated capacity) conditions in accordance with Performance Specifications 2 (PS-2) and 4 (PS-4)
- Conduct the test program with a focus on safety

Montrose performed the tests to measure the emission parameters listed in Tables 1-1 and 1-2.

Table 1-1
Summary of Test Program – Low (Normal) Load

Test Date(s)	Unit ID/ Source Name	Activity/Parameters	Test Methods	No. of Runs	Duration (Minutes)
9/23/2022	EU-BOILER CEMS	Velocity/Volumetric Flow Rate	EPA 1 & 2	12	9-24
9/23/2022	EU-BOILER CEMS	O ₂ , CO ₂	EPA 3A	10	25
9/23/2022	EU-BOILER CEMS	Moisture	EPA 4	4	60
9/23/2022	EU-BOILER CEMS	SO ₂	EPA 6C	10	25
9/23/2022	EU-BOILER CEMS	NO _x	EPA 7E	10	25
9/23/2022	EU-BOILER CEMS	CO	EPA 10	10	25

Table 1-2
Summary of Test Program – High Load

Test Date(s)	Unit ID/ Source Name	Activity/Parameters	Test Methods	No. of Runs	Duration (Minutes)
9/21/2022	EU-BOILER CEMS	Velocity/Volumetric Flow Rate	EPA 1 & 2	12	9
9/21/2022	EU-BOILER CEMS	O ₂ , CO ₂	EPA 3A	12	9
9/21/2022	EU-BOILER CEMS	Moisture	EPA 4	4	60

For each RATA load, nine RATA runs were used to determine the RA of the EU-BOILER CEMS.

To simplify this report, a list of Units and Abbreviations is included in Appendix C.1. Throughout this report, chemical nomenclature, acronyms, and reporting units are not defined. Please refer to the list for specific details.

This report presents the test results and supporting data, descriptions of the testing procedures, descriptions of the facility and sampling locations, and a summary of the quality assurance procedures used by Montrose. The RA test results are summarized and compared to their respective regulatory requirements in Tables 1-3 and 1-4. Detailed results for individual test runs can be found in Section 4.0. All supporting data can be found in the appendices.

The testing was conducted by the Montrose personnel listed in Table 1-5. The tests were conducted according to the test plan (protocol) dated July 20, 2022, that was submitted to EGLE.

RECEIVED

NOV 28 2022

AIR QUALITY DIVISION

Table 1-3
Summary of Part 60/75 RATA Results – EU-BOILER CEMS – Low Load
September 23, 2022

Parameter/Units	Regulatory Reference	RA	Allowable
Part 60			
Nitrogen Oxides (NO_x)			
lb/MMBtu (as NO ₂)	PS-2	5.17	≤ 20.0% of RM
Carbon Monoxide (CO)			
ppmvd @ 3% O ₂	PS-4	6.74	≤ 10% of RM
lb/MMBtu	PS-4	1.27	≤ 5% of AS
Part 75 – Annual (Reduced Frequency)			
Oxygen (O₂)			
% volume dry	App. B Sect. 2.3.1.2	2.63	≤ 7.5% of RM
Volumetric Flow Rate			
scfh	App. B Sect. 2.3.1.2	6.05	≤ 7.5% of RM
Sulfur Dioxide (SO₂)			
ppmvd (low emitter)	App. B Sect. 2.3.1.2	2.34	± 12 ppmvd SO ₂ ⁽¹⁾
Nitrogen Oxides (NO_x)			
ppmvd (low emitter)	App. B Sect. 2.3.1.2	-4.69	± 12 ppmvd NO _x ⁽¹⁾

⁽¹⁾ Alternate is for low emitter (average SO₂ or NO_x RM concentrations are ≤ 250 ppm, or average NO_x RM emission rates are ≤ 0.200 lb/MMBtu)

Table 1-4
Summary of Part 75 RATA Results – EU-BOILER CEMS – High Load
September 21, 2022

Parameter/Units	Regulatory Reference	RA	Allowable
Part 75 – Annual (Reduced Frequency)			
Volumetric Flow Rate			
scfh	App. B Sect. 2.3.1.2	6.21	≤ 7.5% of RM

1.2 Key Personnel

A list of project participants is included below:

Facility Information

Source Location: Genesee Power Station L.P.
 G-5310 N. Dort Highway
 Flint, MI 48505

Project Contact: Roxanna Woodward
 Role: Environmental Manager
 Company: Genesee Power Plant
 Telephone: 810-785-4144 Ext. 224
 Email: roxanna.woodward@cmsenergy.com

Agency Information

Regulatory Agency: EGLE
 Agency Contact: Lindsey Wells
 Telephone: 517-282-2345
 Email: WellsL8@michigan.gov

Testing Company Information

Testing Firm: Montrose Air Quality Services, LLC	
Contact: John Nestor	Robert J. Lisy, Jr.
Title: District Manager	Reporting Hub Manager
Telephone: 248-548-8070	440-262-3760
Email: jonestor@montrose-env.com	rlisy@montrose-env.com

Test personnel and observers are summarized in Table 1-5.

Table 1-5
Test Personnel and Observers

Name	Affiliation	Role/Responsibility
John Nestor	Montrose	District Manager (PM), QI
David Kopenen	Montrose	Field Technician
Roy Zimmer	Montrose	Field Technician
Roxanna Woodward	Genesee Power Station	Test Coordinator
Lindsey Wells	EGLE	Observer

Qualified individual information is presented in Table 1-6.

Table 1-6
Part 75 Qualified Individual Information

Data Element	Information
QI Name	John Nestor
AETB Name	Montrose Air Quality Services, LLC
AETB Phone Number	440-262-3760
AETB Email Address	qualitymanagement@montrose-env.com
Exam Date	Group 5: 1/4/2018
Provider Name	Source Evaluation Society
Provider Email Address	qstiprogram@gmail.com

2.0 Plant and Sampling Location Descriptions

2.1 Process Description, Operation, and Control Equipment

Genesee Power Station L.P. operates a 35 MWnet electric generation group consisting of a wood biomass boiler (EU-BOILER), a selective non-catalytic reduction (SNCR) system, a mechanical multi-cyclone separator (MMS), and an electrostatic precipitator (ESP). The boiler has a spreader-stoker design and is rated at 523 MMBtu/hr. It is able to produce 345 kbl/hr of steam. EU-BOILER was in operation for this test event.

2.2 Facility and Reference Method (RM) CEMS Descriptions

The Facility CEMS analyzer information is presented in Table 2-1, and the RM CEMS analyzer information is presented in Table 2-2.

**Table 2-1
Facility CEMS Information**

Analyzer Type	Manufacturer	Model No.	Serial No.
O ₂	Brand-Gaus	4705	10979/A1633
SO ₂	Thermo Fisher	43i-HL	1127349917
NO _x	CAI	600	Y08035
CO	Thermo Fisher	48IQ	12035010118
Flow	Monitoring Solutions	CEMFLOW FL2000	060515-000-1081-UMCR

**Table 2-2
RM CEMS Information**

Analyzer Type	Manufacturer	Model No.	Serial No.
O ₂	Teledyne	T802	197
CO ₂	Teledyne	T802	197
SO ₂	Western Research	VM-721M	85621
NO _x	Teledyne	T200H	84
CO	Teledyne	T300M	97

2.3 Flue Gas Sampling Location

Information regarding the sampling location is presented in Table 2-3.

Table 2-3
Sampling Location

Sampling Location	Stack Inside Diameter (in.)	Distance from Nearest Disturbance		Number of Traverse Points
		Downstream EPA "B" (in./dia.)	Upstream EPA "A" (in./dia.)	
EU-BOILER Exhaust Stack (SVBOILER)	94.0	576 / 6.1	1,896 / 20.2	Flow: 16 (8/port) Gaseous: 3

The sampling location was verified in the field to conform to EPA Method 1. Acceptable cyclonic flow conditions were confirmed prior to testing using EPA Method 1, Section 11.4. See Appendix A.1 for more information.

2.4 Operating Conditions and Process Data

The CEMS RATAs were performed while EU-BOILER was operating at High Load (>80% of maximum rated capacity) and Low Load (<50% of maximum rated capacity) conditions.

Plant personnel were responsible for establishing the test conditions and collecting all applicable unit-operating data. The Facility CEMS and process data that was provided is presented in Appendix B. Data collected includes the following parameters:

- Facility CEMS data for each 21-minute RATA run
- Unit Load, MW
- Steam Flow, klb/hr (Gaseous Pollutant RATA only)

3.0 Sampling and Analytical Procedures

3.1 Test Methods

The test methods for this test program have been presented in Table 1-1. Additional information regarding specific applications or modifications to standard procedures is presented below.

3.1.1 EPA Method 1, Sample and Velocity Traverses for Stationary Sources

EPA Method 1 is used to assure that representative measurements of volumetric flow rate are obtained by dividing the cross-section of the stack or duct into equal areas, and then locating a traverse point within each of the equal areas. Acceptable sample locations must be located at least two stack or duct equivalent diameters downstream from a flow disturbance and one-half equivalent diameter upstream from a flow disturbance.

The sample port and traverse point locations are detailed in Appendix A.

3.1.2 EPA Method 2, Determination of Stack Gas Velocity and Volumetric Flow Rate (Type S Pitot Tube)

EPA Method 2 is used to measure the gas velocity using an S-type pitot tube connected to a pressure measurement device, and to measure the gas temperature using a calibrated thermocouple connected to a thermocouple indicator. Typically, Type S (Staußcheibe) pitot tubes conforming to the geometric specifications in the test method are used, along with an inclined manometer. The measurements are made at traverse points specified by EPA Method 1.

The typical sampling system is detailed in Figure 3-1.

3.1.3 EPA Method 3A, Determination of Oxygen and Carbon Dioxide Concentrations in Emissions from Stationary Sources (Instrumental Analyzer Procedure)

EPA Method 3A is an instrumental test method used to measure the concentration of O₂ and CO₂ in stack gas. The effluent gas is continuously or intermittently sampled and conveyed to analyzers that measure the concentration of O₂ and CO₂. The performance requirements of the method must be met to validate data.

The typical sampling system is detailed in Figure 3-3.

RECEIVED

NOV 28 2022

AIR QUALITY DIVISION

Figure 3-1
EPA Method 2 Sampling Train

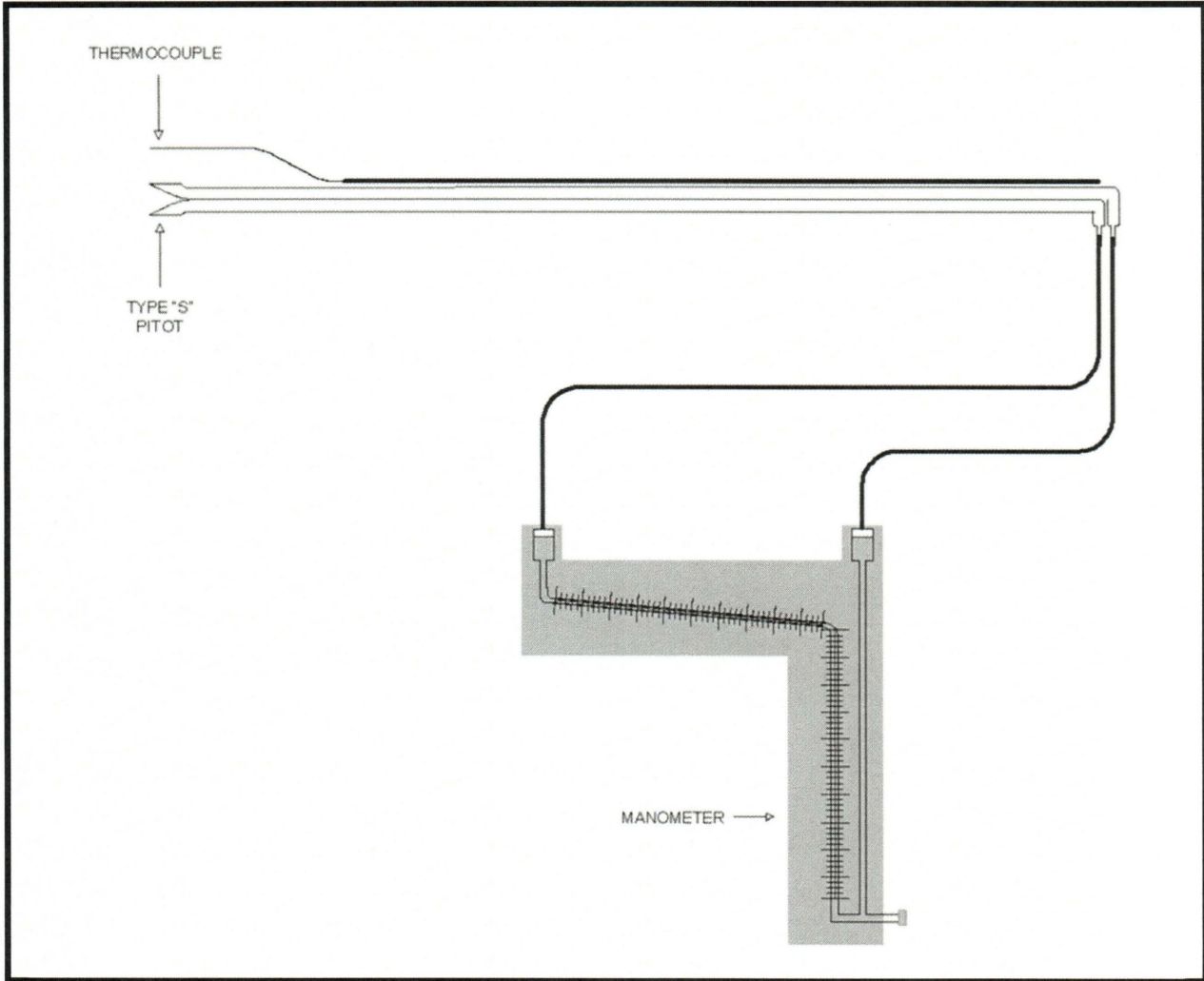

3.1.4 EPA Method 4, Determination of Moisture Content in Stack Gas

EPA Method 4 is a manual, non-isokinetic method used to measure the moisture content of gas streams. Gas is sampled at a constant sampling rate through a probe and impinger train. Moisture is removed using a series of pre-weighed impingers containing methodology-specific liquids and silica gel immersed in an ice water bath. The impingers are weighed after each run to determine the percent moisture.

The typical sampling system is detailed in Figure 3-2.

Figure 3-2
EPA Method 4 (Detached) Sampling Train

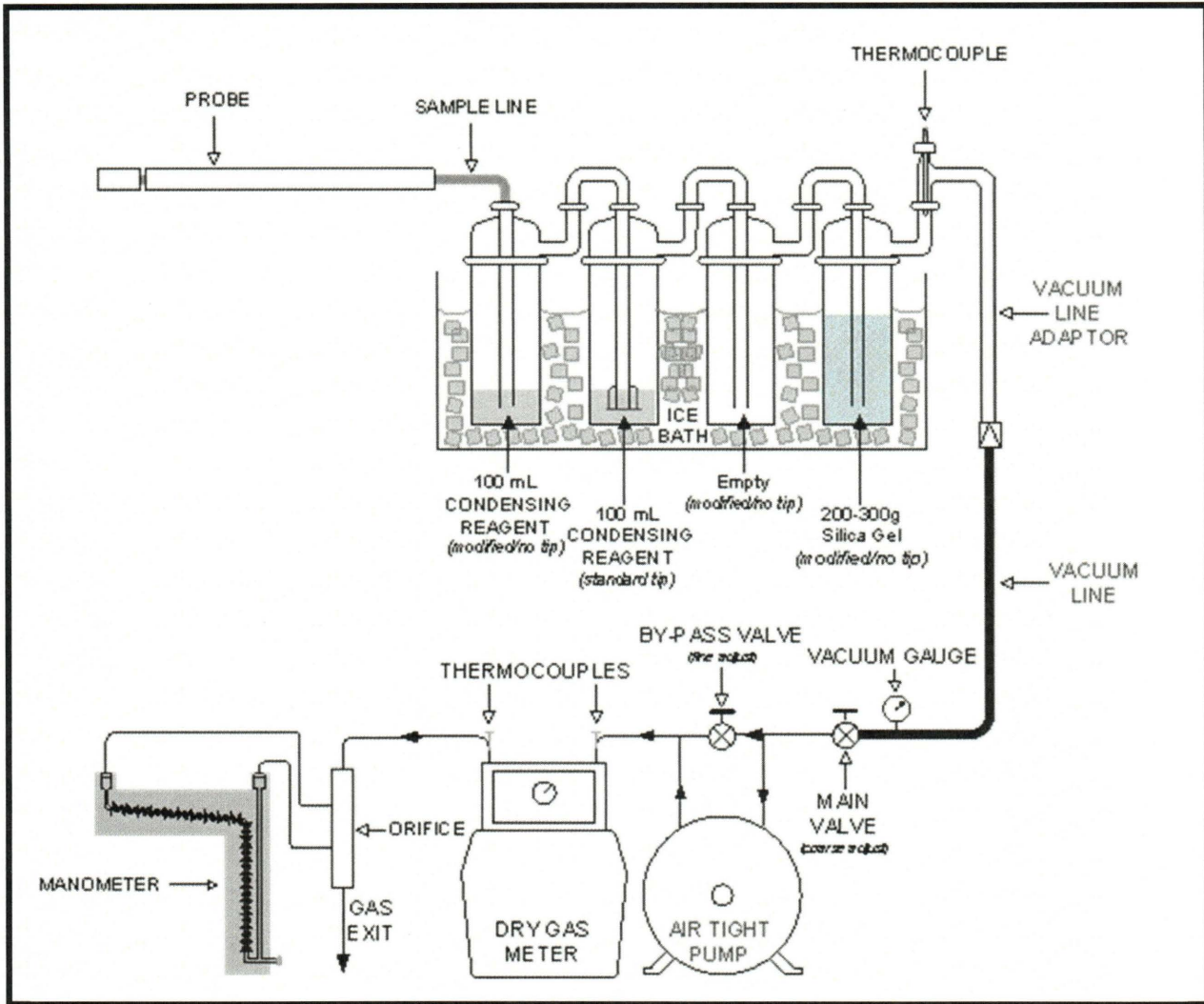

3.1.5 EPA Method 6C, Determination of Sulfur Dioxide Emissions from Stationary Sources (Instrumental Analyzer Procedure)

EPA Method 6C is an instrumental test method used to continuously measure emissions of SO₂. Conditioned gas is sent to an analyzer to measure the concentration of SO₂. The performance requirements of the method must be met to validate the data.

The typical sampling system is detailed in Figure 3-3.

3.1.6 EPA Method 7E, Determination of Nitrogen Oxides Emissions from Stationary Source (Instrumental Analyzer Procedure)

EPA Method 7E is an instrumental test method used to continuously measure emissions of NO_x as NO₂. Conditioned gas is sent to an analyzer to measure the concentration of NO_x. NO and NO₂ can be measured separately or simultaneously together but, for the purposes of this method, NO_x is the sum of NO and NO₂. The performance requirements of the method must be met to validate the data.

The typical sampling system is detailed in Figure 3-3.

3.1.7 EPA Method 10, Determination of Carbon Monoxide Emissions from Stationary Sources (Instrumental Analyzer Procedure)

EPA Method 10 is an instrumental test method used to continuously measure emissions of CO. Conditioned gas is sent to an analyzer to measure the concentration of CO. The performance requirements of the method must be met to validate the data.

The typical sampling system is detailed in Figure 3-3.

Figure 3-3
EPA Methods 3A, 6C, 7E, and 10

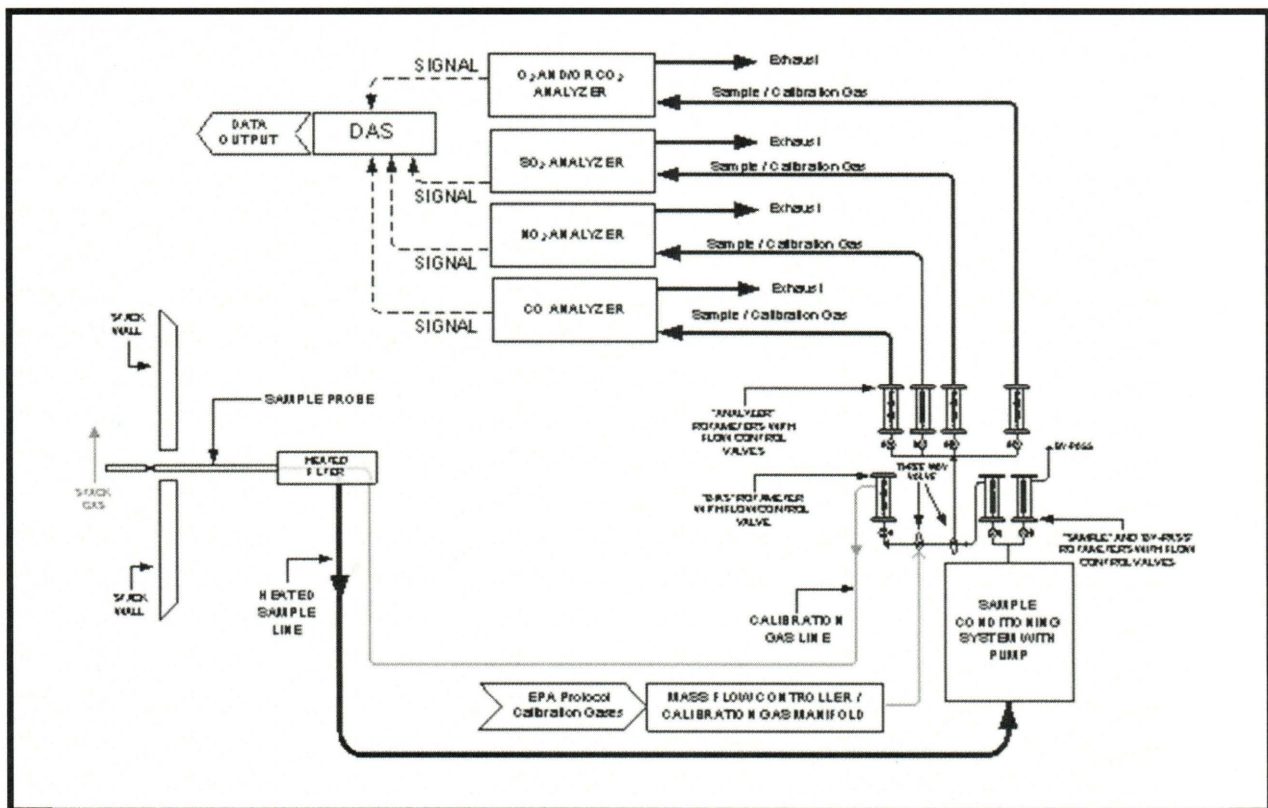

3.1.8 EPA Method 19, Determination of Sulfur Dioxide Removal Efficiency and Particulate Matter, Sulfur Dioxide, and Nitrogen Oxide Emission Rates

EPA Method 19 is a manual method used to determine (a) PM, SO₂, and NO_x emission rates; (b) sulfur removal efficiencies of fuel pretreatment and SO₂ control devices; and (c) overall reduction of potential SO₂ emissions. This method provides data reduction procedures, but does not include any sample collection or analysis procedures.

EPA Method 19 is used to calculate mass emission rates in units of lb/MMBtu. EPA Method 19, Table 19-2 contains a list of assigned fuel factors for different types of fuels, which can be used for these calculations.

3.1.9 EPA Performance Specification 2, Specifications and Test Procedures for SO₂ and NO_x for Continuous Emission Monitoring Systems in Stationary Sources

EPA Performance Specification 2 is a specification used to evaluate the acceptability of SO₂ and NO_x CEMS. The evaluation is conducted at the time of installation or soon after, and whenever specified in the regulations. The CEMS may include, for certain stationary sources, a diluent (O₂ or CO₂) monitor. The RA and CD tests are conducted to determine conformance of the CEMS to the specification.

3.1.10 EPA Performance Specification 3, Specifications and Test Procedures for O₂ and CO₂ Continuous Monitoring Systems in Stationary Sources

EPA Performance Specification 3 is a specification used to evaluate the acceptability of O₂ and CO₂ CEMS. The evaluation is conducted at the time of installation or soon after, and whenever specified in the regulations. This specification applies to O₂ or CO₂ monitors that are not included under PS-2. The RA and CD tests are conducted to determine conformance of the CEMS to the specification.

3.1.11 EPA Performance Specification 4, Specifications and Test Procedures for Carbon Monoxide Continuous Emission Monitoring Systems in Stationary Sources

EPA Performance Specification 4 is a specification used to evaluate the acceptability of CO CEMS. The evaluation is conducted at the time of installation or soon after, and whenever specified in the regulations. This specification was developed primarily for CEMS having span values of 1,000 ppmv CO. The RA and CD tests are conducted to determine conformance of the CEMS to the specification.

3.1.12 EPA Performance Specification 6, Specifications and Test Procedures for Continuous Emission Rate Monitoring Systems in Stationary Sources

EPA Performance Specification 6 is a specification used to evaluate the acceptability of CERMS. The evaluation is conducted at the time of installation or soon after, and whenever specified in the regulations. The RA and CD tests are conducted to determine conformance of the CERMS to the specification.

3.2 Process Test Methods

The test plan did not require that process samples be collected during this test program; therefore, no process sample data are presented in this test report.

4.0 Test Discussion and Results

4.1 Field Test Deviations and Exceptions

The CEMS analyzers for EPA Method 3A, 7E, and 10 had an adaptive filter setting disabled in order to match response times with the CEMS.

A method deviation from 21-minute RATA runs to 25-minute RATA runs was approved by EGLE.

4.2 Presentation of Results

The RA results are compared to the regulatory requirements in Tables 1-2 and 1-3. The results of individual test runs performed during the Low (Normal) Load Gaseous Pollutant RATA are presented in Tables 4-1 through 4-6. The results of individual test runs performed during the Low (Normal) Load Flow RATA are presented in Table 4-7, and the results of individual test runs performed during the High Load Flow RATA are presented in Table 4-8. Emissions are reported in units consistent with those in the applicable regulations or requirements. Additional information is included in the appendices as presented in the Table of Contents.

Per EPA Method 2H Section 2.2.2, a wall adjustment factor (WAF) of 0.995 was applied to the EU-BOILER Exhaust Stack.

Table 4-1
NO_x (lb/MMBtu) Part 60 RATA Results -
EU-BOILER CEMS -Low Load

Run #	Date	Time	RM	CEMS	Difference	Run Used (Y/N)	Unit Load (MW)
1	9/23/2022	8:23-8:48	0.1391	0.1460	-0.0069	Y	12
2	9/23/2022	9:06-9:31	0.1374	0.1440	-0.0066	Y	12
3	9/23/2022	9:49-10:14	0.1400	0.1450	-0.0050	Y	12
4	9/23/2022	11:13-11:38	0.1450	0.1530	-0.0080	Y	12
5	9/23/2022	12:14-12:39	0.1451	0.1520	-0.0069	Y	12
6	9/23/2022	13:05-13:30	0.1253	0.1310	-0.0057	Y	12
7	9/23/2022	13:57-14:22	0.1357	0.1440	-0.0083	N	12
8	9/23/2022	14:42-15:07	0.1389	0.1440	-0.0051	Y	12
9	9/23/2022	15:36-16:01	0.1378	0.1450	-0.0072	Y	12
10	9/23/2022	16:40-17:05	0.1371	0.1430	-0.0059	Y	12
Averages			0.1384	0.1448	-0.0064		12
Standard Deviation			0.00102				
Confidence Coefficient (CC)			0.00078				
Unit Load			Low	<50% of maximum rated capacity			
RA based on mean RM value			5.17	%			

**Table 4-2
NO_x (ppmvd) Part 75 RATA Results -
EU-BOILER CEMS – Low Load**

Run #	Date	Time	RM	CEMS	Difference	Run Used (Y/N)	Unit Load (MW)
1	9/23/2022	8:23-8:48	83.720	88.200	-4.480	Y	12
2	9/23/2022	9:06-9:31	83.235	87.600	-4.365	Y	12
3	9/23/2022	9:49-10:14	83.628	88.200	-4.572	Y	12
4	9/23/2022	11:13-11:38	86.666	92.200	-5.534	Y	12
5	9/23/2022	12:14-12:39	87.241	92.000	-4.759	Y	12
6	9/23/2022	13:05-13:30	76.374	80.300	-3.926	Y	12
7	9/23/2022	13:57-14:22	80.596	86.800	-6.204	N	12
8	9/23/2022	14:42-15:07	82.829	87.400	-4.571	Y	12
9	9/23/2022	15:36-16:01	82.236	87.900	-5.664	Y	12
10	9/23/2022	16:40-17:05	82.832	87.200	-4.368	Y	12
Averages			83.196	87.889	-4.693		12
Unit Load			Low	<50% of maximum rated capacity			
RA based on mean difference			-4.69	ppmvd as NO _x			

Table 4-3
SO₂ (ppmvd) Part 75 RATA Results -
EU-BOILER CEMS – Low Load

Run #	Date	Time	RM	CEMS	Difference	Run Used (Y/N)	Unit Load (MW)
1	9/23/2022	8:23-8:48	18.886	15.200	3.686	Y	12
2	9/23/2022	9:06-9:31	17.605	14.900	2.705	Y	12
3	9/23/2022	9:49-10:14	12.752	10.100	2.652	Y	12
4	9/23/2022	11:13-11:38	17.737	13.900	3.837	N	12
5	9/23/2022	12:14-12:39	17.846	14.700	3.146	Y	12
6	9/23/2022	13:05-13:30	3.858	2.800	1.058	Y	12
7	9/23/2022	13:57-14:22	10.226	7.700	2.526	Y	12
8	9/23/2022	14:42-15:07	7.950	6.000	1.950	Y	12
9	9/23/2022	15:36-16:01	8.354	6.500	1.854	Y	12
10	9/23/2022	16:40-17:05	11.457	9.972	1.485	Y	12
Averages			12.104	9.764	2.340		12
Unit Load			Low	<50% of maximum rated capacity			
RA based on mean difference			2.34	ppmvd as SO ₂			

Table 4-4
CO (lb/MMBtu) RATA Results -
EU-BOILER CEMS – Low Load

Run #	Date	Time	RM	CEMS	Difference	Run Used (Y/N)	Unit Load (MW)
1	9/23/2022	8:23-8:48	0.0644	0.0600	0.0044	Y	12
2	9/23/2022	9:06-9:31	0.0677	0.0650	0.0027	Y	12
3	9/23/2022	9:49-10:14	0.0589	0.0550	0.0039	Y	12
4	9/23/2022	11:13-11:38	0.0639	0.0600	0.0039	Y	12
5	9/23/2022	12:14-12:39	0.0587	0.0550	0.0037	Y	12
6	9/23/2022	13:05-13:30	0.1236	0.1160	0.0076	N	12
7	9/23/2022	13:57-14:22	0.0800	0.0750	0.0050	Y	12
8	9/23/2022	14:42-15:07	0.0797	0.0750	0.0047	Y	12
9	9/23/2022	15:36-16:01	0.0592	0.0560	0.0032	Y	12
10	9/23/2022	16:40-17:05	0.0619	0.0590	0.0029	Y	12
Averages			0.0660	0.0622	0.0038		12
Applicable Standard (AS)			0.35	lb/MMBtu			
Standard Deviation			0.00080				
Confidence Coefficient (CC)			0.00062				
Unit Load			Low	<50% of maximum rated capacity			
RA based on AS			1.27	%			

Table 4-5
CO (ppmvd corrected to 3% O₂) RATA Results -
EU-BOILER CEMS – Low Load

Run #	Date	Time	RM	CEMS	Difference	Run Used (Y/N)	Unit Load (MW)
1	9/23/2022	8:23-8:48	81.943	76.300	5.643	Y	12
2	9/23/2022	9:06-9:31	86.154	82.000	4.154	Y	12
3	9/23/2022	9:49-10:14	74.943	70.300	4.643	Y	12
4	9/23/2022	11:13-11:38	81.288	76.300	4.988	Y	12
5	9/23/2022	12:14-12:39	74.695	70.300	4.395	Y	12
6	9/23/2022	13:05-13:30	157.217	147.700	9.517	N	12
7	9/23/2022	13:57-14:22	101.790	95.500	6.290	Y	12
8	9/23/2022	14:42-15:07	101.419	95.100	6.319	Y	12
9	9/23/2022	15:36-16:01	75.273	71.000	4.273	Y	12
10	9/23/2022	16:40-17:05	78.696	75.072	3.624	Y	12
Averages			84.022	79.097	4.925		12
Standard Deviation			0.96157				
Confidence Coefficient (CC)			0.73912				
Unit Load			Low	<50% of maximum rated capacity			
RA based on mean RM value			6.74	%			

Table 4-6
O₂ (%-Dry) Part 75 RATA Results -
EU-BOILER CEMS – Low Load

Run #	Date	Time	RM	CEMS	Difference	Run Used (Y/N)	Unit Load (MW)
1	9/23/2022	8:23-8:48	6.989	6.900	0.089	Y	12
2	9/23/2022	9:06-9:31	6.898	6.800	0.098	Y	12
3	9/23/2022	9:49-10:14	7.098	6.900	0.198	Y	12
4	9/23/2022	11:13-11:38	7.087	7.000	0.087	Y	12
5	9/23/2022	12:14-12:39	7.007	6.900	0.107	Y	12
6	9/23/2022	13:05-13:30	6.809	6.700	0.109	Y	12
7	9/23/2022	13:57-14:22	7.180	6.900	0.280	N	12
8	9/23/2022	14:42-15:07	7.125	6.900	0.225	Y	12
9	9/23/2022	15:36-16:01	7.111	6.900	0.211	Y	12
10	9/23/2022	16:40-17:05	6.935	6.788	0.147	Y	12
Averages			7.006	6.865	0.141		12
Standard Deviation			0.05576				
Confidence Coefficient (CC)			0.04286				
Unit Load			Low	<50% of maximum rated capacity			
RA based on mean RM value			2.63	%			

Table 4-7
Volumetric Flow Rate (scfh) Part 75 RATA Results -
EU-BOILER CEMS – Low Load

Run #	Date	Time	RM	CEMS	Difference	Run Used (Y/N)	Unit Load (MW)
1	9/23/2022	8:23-8:47	3,089,249	2,854,070	235,179	N	12
2	9/23/2022	9:06-9:30	3,099,959	2,861,727	238,231	N	12
3	9/23/2022	9:49-10:13	3,066,310	2,874,938	191,372	Y	12
4	9/23/2022	11:13-11:37	3,051,824	2,881,037	170,787	Y	12
5	9/23/2022	12:14-12:38	3,042,101	2,891,301	150,799	Y	12
6	9/23/2022	13:05-13:29	2,968,469	2,893,800	74,669	Y	12
7	9/23/2022	13:57-14:21	3,119,242	2,904,836	214,406	N	12
8	9/23/2022	14:42-15:06	2,989,822	2,927,285	62,537	Y	12
9	9/23/2022	15:36-16:00	2,957,494	2,889,119	68,375	Y	12
10	9/23/2022	16:35-16:44	3,079,701	2,887,743	191,958	Y	12
11	9/23/2022	16:45-16:54	3,036,417	2,862,769	173,647	Y	12
12	9/23/2022	16:55-17:05	3,038,286	2,858,839	179,447	Y	12
Averages			3,025,603	2,885,204	140,399		12
Standard Deviation			55,327				
Confidence Coefficient (CC)			42,528				
Unit Load			Low	<50% of maximum rated capacity			
RA based on mean RM value			6.05	%			

**Table 4-8
Volumetric Flow Rate (scfh) Part 75 RATA Results -
EU-BOILER CEMS – High Load**

Run #	Date	Time	RM	CEMS	Difference	Run Used (Y/N)	Unit Load (MW)
1	9/21/2022	11:15-11:24	7,767,563	7,202,849	564,714	N	40
2	9/21/2022	11:25-11:34	7,634,953	7,281,617	353,336	Y	40
3	9/21/2022	11:35-11:44	7,662,903	7,221,364	441,539	Y	40
4	9/21/2022	12:52-13:01	7,825,598	7,337,559	488,039	Y	40
5	9/21/2022	13:02-13:11	7,695,487	7,269,581	425,906	Y	40
6	9/21/2022	13:12-13:21	7,764,966	7,335,070	429,896	Y	40
7	9/21/2022	14:43-14:52	7,653,876	7,215,686	438,191	Y	40
8	9/21/2022	14:53-15:02	7,917,982	7,171,680	746,302	N	40
9	9/21/2022	15:03-15:12	7,620,387	7,165,464	454,923	Y	40
10	9/21/2022	15:30-15:39	7,781,012	7,318,973	462,039	Y	40
11	9/21/2022	15:40-15:49	7,700,970	7,190,665	510,306	Y	40
12	9/21/2022	15:50-15:59	7,858,644	7,211,553	647,091	N	40
Averages			7,704,461	7,259,553	444,908		40
Standard Deviation			44,101				
Confidence Coefficient (CC)			33,899				
Unit Load			High	<80% of maximum rated capacity			
RA based on mean RM value			6.21	%			

5.0 Internal QA/QC Activities

5.1 QA/QC Audits

Table 5-1 presents a summary of the gas cylinder information.

Table 5-1
Part 60/75 Gas Cylinder Information

Gas Type	Gas Concentrations	Cylinder ID	Expiration Date
O ₂ , Balance N ₂	20.00%	CC469833	12/17/2029
O ₂ , Balance N ₂	10.18%	CC313723	3/14/2030
CO ₂ , Balance N ₂	20.78%	CC469833	12/17/2029
CO ₂ , Balance N ₂	10.15%	CC313723	3/14/2030
SO ₂ , Balance N ₂	24.8 ppmv	XC034660B	8/26/2025
SO ₂ , Balance N ₂	49.48 ppmv	ALM-005017	5/9/2030
NO _x , Balance N ₂	91.39 ppmv	AAL069508	11/30/2029
NO _x , Balance N ₂	188.1 ppmv	CC64077	7/15/2024
CO, Balance N ₂	502.2 ppmv	CC234418	2/27/2026
CO, Balance N ₂	998.4 ppmv	XC012998B	12/23/2028

The meter box and sampling train used during sampling performed within the requirements of their respective methods. All post-test leak checks, minimum metered volumes met the applicable QA/QC criteria.

EPA Method 3A, 6C, 7E, and 10 calibration audits were all within the measurement system performance specifications for the calibration drift checks, system calibration bias checks, and calibration error checks.

The NO₂ to NO converter efficiency check of the analyzer was conducted per the procedures in EPA Method 7E, Section 16.2.2. The conversion efficiency met the criteria.

5.2 QA/QC Discussion

All QA/QC criteria were met during this test program.

RECEIVED

NOV 28 2022

AIR QUALITY DIVISION

5.3 Quality Statement

Montrose is qualified to conduct this test program and has established a quality management system that led to accreditation with ASTM Standard D7036-04 (Standard Practice for Competence of Air Emission Testing Bodies). Montrose participates in annual functional assessments for conformance with D7036-04 which are conducted by the American Association for Laboratory Accreditation (A2LA). All testing performed by Montrose is supervised on site by at least one Qualified Individual (QI) as defined in D7036-04 Section 8.3.2. Data quality objectives for estimating measurement uncertainty within the documented limits in the test methods are met by using approved test protocols for each project as defined in D7036-04 Sections 7.2.1 and 12.10. Additional quality assurance information is included in the report appendices. The content of this report is modeled after the EPA Emission Measurement Center Guideline Document (GD-043).