



Consumers Energy

Count on Us[®]

40 CFR Part 60 Subpart JJJJ Continuous Compliance Test Report

EUEMERGGEN

Consumers Energy Company
White Pigeon Compressor Station
68536 A Road,
White Pigeon, MI 49099
SRN: N5573

April 19, 2023

Test Date: February 22, 2023

Test Performed by the Consumers Energy Company
Regulatory Compliance Testing Section
Air Emissions Testing Body
Laboratory Services Section
Work Orders 6515951
Version No.: 1.0

TABLE OF CONTENTS

EXECUTIVE SUMMARY	IV
1.0 INTRODUCTION	1
1.1 IDENTIFICATION, LOCATION, AND DATES OF TESTS	1
1.2 PURPOSE OF TESTING.....	1
1.3 BRIEF DESCRIPTION OF SOURCE	2
2.0 SUMMARY OF RESULTS	3
2.1 OPERATING DATA	3
2.2 APPLICABLE PERMIT INFORMATION.....	3
2.3 RESULTS	3
3.0 SOURCE DESCRIPTION	4
3.1 PROCESS.....	4
3.2 PROCESS FLOW.....	5
3.3 MATERIALS PROCESSED.....	5
3.4 RATED CAPACITY	5
3.5 PROCESS INSTRUMENTATION.....	6
4.0 SAMPLING AND ANALYTICAL PROCEDURES.....	6
4.1 DESCRIPTION OF SAMPLING TRAIN AND FIELD PROCEDURES	6
4.2 SAMPLE LOCATION AND TRAVERSE POINTS (USEPA METHOD 1).....	7
4.3 MOISTURE CONTENT (USEPA ALT-008).....	8
4.4 O ₂ , NO _x , AND CO (USEPA METHODS 3A, 7E, AND 10).....	9
4.5 EMISSION RATES (USEPA METHOD 19)	11
4.6 VOLATILE ORGANIC COMPOUNDS (USEPA METHODS 18 AND 25A).....	11
5.0 TEST RESULTS AND DISCUSSION	12
5.1 TABULATION OF RESULTS.....	12
5.2 SIGNIFICANCE OF RESULTS.....	13
5.3 VARIATIONS FROM SAMPLING OR OPERATING CONDITIONS.....	13
5.4 AIR POLLUTION CONTROL DEVICE MAINTENANCE	13
5.5 RE-TEST DISCUSSION	13
5.6 RESULTS OF AUDIT SAMPLES	13
5.7 CALIBRATION SHEETS	14
5.8 SAMPLE CALCULATIONS.....	14
5.9 FIELD DATA SHEETS.....	14
5.10 LABORATORY QUALITY ASSURANCE / QUALITY CONTROL PROCEDURES	14
5.11 QA/QC BLANKS	14

FIGURES

FIGURE 3-1. FOUR-STROKE ENGINE PROCESS DIAGRAM.....	5
FIGURE 4-1. EUEMERGGEN CATERPILLAR MODEL G3512B ENGINE DIAGRAM.....	8
FIGURE 4-2. ALTERNATIVE METHOD 008 MOISTURE SAMPLE APPARATUS.....	9
FIGURE 4-3. USEPA METHODS 3A, 7E, AND 10 SAMPLING SYSTEM.....	10
FIGURE 4-4. USEPA METHOD 19 EMISSION FLOW RATE EQUATION.....	11
FIGURE 4-5. 40 CFR PART 60 SUBPART JJJJ EQUATION 1, 2, 3.....	11
FIGURE 4-6. USEPA METHOD 25A SAMPLE APPARATUS.....	12

TABLES

TABLE E-1 SUMMARY OF TEST RESULTS.....	IV
TABLE 1-1 EUEMERGGEN EMISSION LIMITS.....	1
TABLE 1-2 CONTACT INFORMATION.....	2
TABLE 2-1 SUMMARY OF TEST RESULTS.....	3
TABLE 3-1 SUMMARY OF ENGINE SPECIFICATIONS.....	4
TABLE 4-1 TEST METHODS.....	6
TABLE 4-2 TEST MATRIX.....	7
TABLE 5-1 QA/QC PROCEDURES.....	13

APPENDICES

Appendix Table	Table 1 - EUEMERGGEN Emission Rates and Process Data
Appendix A	Sample Calculations
Appendix B	Field Data Sheets
Appendix C	Operating Data
Appendix D	Supporting Documentation

EXECUTIVE SUMMARY

Consumers Energy Regulatory Compliance Testing Section (RCTS) conducted continuous compliance testing on EUEMERGGEN at the White Pigeon Compressor Station in White Pigeon, Michigan on February 22, 2023.

The engine is a natural gas-fired, 4-stroke, lean-burn (4SLB), reciprocating internal combustion engine (RICE) used to drive an emergency generator operated as needed at the White Pigeon Compressor Station located in White Pigeon, Michigan.

The test program was conducted to satisfy performance test requirements and evaluate compliance with the *Standards of Performance for Stationary Spark Ignition (SI) Internal Combustion Engines (ICE)*, 40 CFR Part 60, Subpart JJJJ and MI-ROP-N5573-2018. Please note that while the engine is also subject to 40 CFR Part 63, Subpart ZZZZ, *National Emissions Standards for Hazardous Air Pollutants for Stationary Reciprocating Internal Combustion Engines*; pursuant to §63.6590(c)(1), compliance to this regulation is demonstrated via meeting the emission limits of Subpart JJJJ.

Three, 60-minute tests measuring exhaust emissions of nitrogen oxides (NO_x), carbon monoxide (CO), volatile organic compounds (VOC's), and oxygen (O₂) were conducted at the oxidation catalyst outlet following the procedures in United States Environmental Protection Agency (USEPA) Reference Methods (RM) 1, 3A, 4 (ALT-008), 7E, 10, 19, and 25A in 40 CFR Part 60, Appendix A. There were no deviations from the approved stack test protocol submitted on January 17, 2023, or associated USEPA RM. A ten-minute pause did occur during Run #3 due to a NO_x analyzer pump failure. Once the issue was resolved and the instrument was responding as expected the test run resumed.

The test results summarized in Table E-1 indicate EUEMERGGEN is operating in compliance with 40 CFR Part 60, Subpart JJJJ. Detailed results are presented in Appendix Table 1. Sample calculations and field data sheets are presented in Appendices A and B. Engine operating data and supporting documentation are provided in Appendices C and D.

**Table E-1
Summary of Test Results**

Parameter	Units	Result	40 CFR Part 60, Subpart JJJJ Limits ¹	ROP Limits
NO _x	g/HP-hr	0.5	2.0	0.5
	ppmvd at 15% O ₂	36	160	
CO	g/HP-hr	2.2	4.0	4.0
	ppmvd at 15% O ₂	287	540	
VOC (as NMOC)	g/HP-hr	0.5	1.0	1.0
	ppmvd at 15% O ₂	35	86	
NO _x	nitrogen oxides			
CO	carbon monoxide			
VOC (as NMOC)	volatile organic compounds as non-methane organic compounds			
g/HP-hr	grams per horsepower hour			
1	Owners and operators of stationary non-certified SI engines may choose to comply with the emission standards in units of either g/HP-hr or ppmvd at 15 percent O ₂ .			

1.0 SUMMARY OF RESULTS

This report summarizes compliance air emission test results from EUEMERGGEN conducted February 22, 2023, at the Consumers Energy White Pigeon Compressor Station (WPCS) in White Pigeon, Michigan.

This document follows the Michigan Department of Environment, Great Lakes and Energy (EGLE) format described in the November 2019, Format for Submittal of Source Emission Test Plans and Reports. Reproducing only a portion of this report may omit critical substantiating documentation or cause information to be taken out of context. If any portion of this report is reproduced, please exercise due care in this regard.

1.1 IDENTIFICATION, LOCATION, AND DATES OF TESTS

Consumers Energy Regulatory Compliance Testing Section (RCTS) conducted nitrogen oxides (NO_x), carbon monoxide (CO), and volatile organic compound (VOC) testing of a natural gas-fired 4-stroke lean burn (4SLB), Caterpillar Model G3516B LE reciprocating internal combustion engine (RICE) designated as EUEMERGGEN at the White Pigeon Compressor Station in White Pigeon, Michigan.

A test protocol outlining the proposed testing and data quality objectives was submitted to EGLE on January 17, 2023, and subsequently approved by Mr. Trevor Droste, Environmental Quality Analyst, in a letter dated February 6, 2023. There were no deviations from the approved stack test protocol or associated United States Environmental Protection Agency (USEPA) reference methods (RM).

1.2 PURPOSE OF TESTING

The test was conducted to satisfy performance test requirements and verify compliance with USEPA 40 CFR Part 60, Subpart JJJJ, *Standards of Performance for Stationary Spark Ignition Internal Combustion Engines*. EUEMERGGEN is also subject to 40 CFR Part 63, Subpart ZZZZ, *National Emissions Standards for Hazardous Air Pollutants (NESHAP) for Stationary Reciprocating Internal Combustion Engines*, however as a new stationary RICE located at an area source, 40 CFR 63 §63.6590(c)(1) states that NESHAP test requirements do not apply when the engine is meeting 40 CFR Part 60 Subpart JJJJ requirements. The applicable emission limits are shown in Table 1-1.

**Table 1-1
EUEMERGGEN Emission Limits**

Parameter	Emission Limit	Units	Applicable Requirement
NO _x	0.5	g/BHP-hr	MI-ROP-N5573-2018: EUEMERGGEN 1.1
	160	ppmvd at 15% O ₂	
CO	2.0	g/BHP-hr	40 CFR Part 60, Subpart JJJJ, Table 1 ^a
	4.0	g/BHP-hr	
VOC	540	ppmvd at 15% O ₂	
	1.0	g/BHP-hr	
	86	ppmvd at 15% O ₂	
NO _x nitrogen oxides CO carbon monoxide VOC volatile organic compounds (non-methane organic compounds (NMOC)) g/BHP-hr grams per brake horsepower hour ^a Emission limit criteria must be met with the engine operating at or within ± 10 percent of 100 peak (or highest achievable) load. Owners and operators of stationary non-certified SI engines may choose to comply with the emission standards in units of either g/HP-hr or ppmvd at 15 percent O ₂ .			

1.3 BRIEF DESCRIPTION OF SOURCE

EUEMERGGEN is classified as a four-stroke lean burn natural gas-fired, spark-ignition reciprocating internal combustion engine, which is located and operating at the White Pigeon Compressor Station in White Pigeon, Michigan. The facility operates a Caterpillar Model G3516B LE 4SLB engine to turn an emergency generator to provide temporary electricity to the station during power outages.

Table 1-2 presents contact information of personnel involved in the test program.

**Table 1-2
Contact Information**

Program Role	Contact	Address
Statewide Regulatory Oversight	Ms. Gina Angelloti Technical Programs Unit Supervisor 517-335-4874 AngellotiR1@michigan.gov	EGLE Technical Programs Unit 525 W. Allegan, Constitution Hall, 2 nd Floor S Lansing, Michigan 48933-1502
District Regulatory Oversight	Mr. Rex Lane District Supervisor 269-312-1540 laner@michigan.gov	EGLE – Air Quality Division Kalamazoo / Southwest Michigan District 7953 Adobe Road Kalamazoo, Michigan 49009-5026
Responsible Official	Mr. Avelock Robinson Director of Gas Compression Operations 586-716-3326 avelock.robinson@cmsenergy.com	Consumers Energy Company St. Clair Compressor Station 10021 Marine City Highway Ira, Michigan 48023
Corporate Air Quality Contact	Ms. Amy Kapuga Senior Engineer II 517-788-2201 amy.kapuga@cmsenergy.com	Consumers Energy Company Environmental Services Department 1945 West Parnall Road Jackson, Michigan 49201
Field Environmental Coordinator	Mr. Frank Rand Senior Environmental Analyst 704-850-4209 frank.randjr@cmsenergy.com	Consumers Energy Company South Monroe Service Center (SMO-100-4) 7116 Crab Road Temperance, MI 48182
Facility Leader	Mr. Tim Wolf Gas Field Lead 269-483-2902 timothy.Wolf@cmsenergy.com	Consumers Energy Company White Pigeon Compressor Station 68536 A Road, Route 1 White Pigeon, Michigan 49099
Test Team Representative	Mr. Joe Gallagher, QSTI Engineering Technical Analyst 989-450-9420 joseph.gallagher@cmsenergy.com	Consumers Energy Company L & D Training Center 17010 Croswell Street West Olive, Michigan 49460

2.0 SUMMARY OF RESULTS

2.1 OPERATING DATA

During the performance test the engine fired natural gas and operated within 10% of 100 percent peak (or the highest achievable) load. The performance testing was conducted with the engine operating at an average 90.1% electrical load and 87.6% horsepower, based on the maximum manufacturer's design capacity at engine and compressor site conditions. Refer to Appendix D for detailed operating data.

2.2 APPLICABLE PERMIT INFORMATION

The White Pigeon Compressor Station is assigned State of Michigan Registration Number (SRN) N5573 and operates in accordance with air permit MI-ROP-N5573-2018. EUEMERGGEN is the emission unit source identification. Incorporated within the permit are the applicable requirements of 40 CFR Part 60, Subpart JJJJ – *Standards of Performance for Stationary Spark Ignition Internal Combustion Engines*.

2.3 RESULTS

The test results in Tables 2-1 indicate the engine complies with the applicable emission limits and associated operating requirements.

Detailed results are presented in Appendix Table 1. A discussion of the results is presented in Section 5.0. Sample calculations and field data sheets are presented in Appendices A and B. Engine operating data and supporting documentation are provided in Appendices C and D.

Table 2-1
Summary of Test Results

Parameter	Units	Result	40 CFR Part 60, Subpart JJJJ Limits ¹	ROP Limits
NO _x	g/HP-hr	0.5	2.0	0.5
	ppmvd at 15% O ₂	36	160	
CO	g/HP-hr	2.2	4.0	4.0
	ppmvd at 15% O ₂	287	540	
VOC (as NMOC)	g/HP-hr	0.5	1.0	1.0
	ppmvd at 15% O ₂	35	86	
NO _x	nitrogen oxides			
CO	carbon monoxide			
VOC (as NMOC)	volatile organic compounds as non-methane organic compounds			
g/HP-hr	grams per horsepower hour			
1	Owners and operators of stationary non-certified SI engines may choose to comply with the emission standards in units of either g/HP-hr or ppmvd at 15 percent O ₂ .			

3.0 SOURCE DESCRIPTION

EUEMERGGEN is a natural gas fired RICE used to drive an emergency generator operated as needed at the White Pigeon Compressor Station. A summary of the engine specifications from vendor data are provided in Table 3-1.

Table 3-1
Summary of Engine Specifications

Parameter ¹	EUEMERGGEN
Make	Caterpillar
Model	G3516B LE
Purchase Year	2008
Installation Date	June 15, 2010
Output (brake-horsepower)	1,818
Heat Input, LHV (mmBtu/hr)	12.8
Exhaust Flow Rate (ACFM, wet)	11,923
Exhaust Gas Temp. (°F)	974
Engine Outlet O ₂ (Vol-%, dry)	7.7
1 Engine specifications are based upon vendor data for operation at 100% of rated engine capacity	

3.1 PROCESS

EUEMERGGEN is a natural gas-fired, spark ignited, 4SLB RICE installed in 2010. In the four-stroke engine, air is aspirated into the cylinder during the downward travel of the piston on the intake stroke. The fuel charge is injected with the piston near the bottom of the intake stroke and the intake valves close as the piston moves to the top of the cylinder, compressing the air/fuel mixture. A spark plug at the top of the cylinder ignites the air/fuel charge causing the charge to expand and initiate the downward movement of the piston, called the power stroke. As the piston reaches the bottom of the power stroke, valves open to exhaust combustion products from the cylinder as the piston travels upward. A new air-to-fuel charge is injected as the piston moves downward in a new intake stroke.

The engine provides mechanical shaft power to turn an emergency generator to provide temporary electricity to the station during power outages. Refer to Figure 3-1 for a four-stroke engine process diagram.

Figure 3-1. Four-Stroke Engine Process Diagram

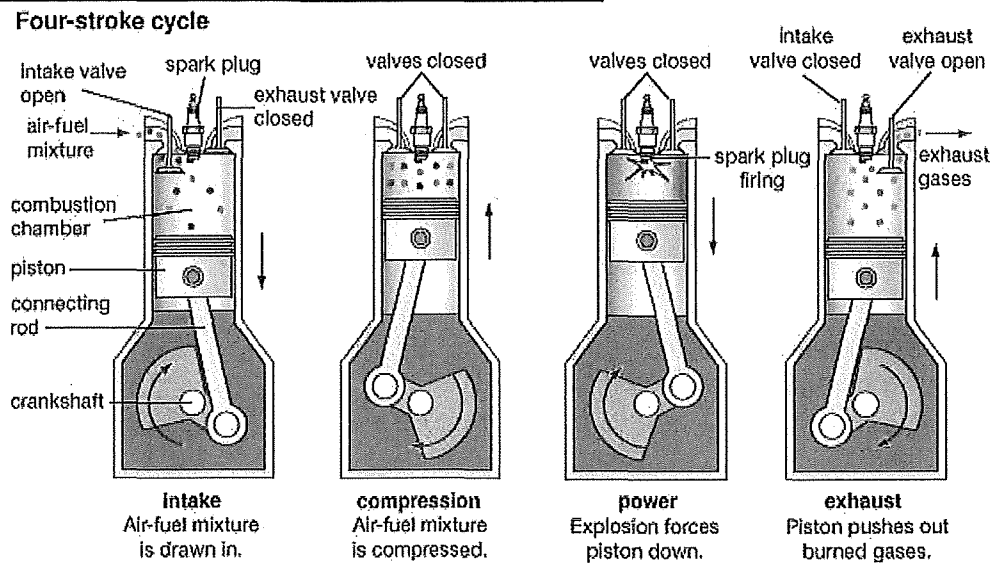

3.2 PROCESS FLOW

Located in southwest St. Joseph County, the White Pigeon Compressor Station helps maintain natural gas pressures in the natural gas pipeline system. The main function of the station is to help ensure the ability to maintain required pressures within the natural gas distribution system.

EUEMERGGEN is a natural gas reciprocating engine used to turn an emergency generator to provide temporary electricity to the station during power outages. Natural gas combustion by-products are controlled through parametric controls (i.e., timing and operating at a lean air-to-fuel ratio) and lean burn combustion technology. The Caterpillar engine includes an Advanced Digital Engine Management (ADEM) III electronic control system. The ADEM III electronic controls integrate governing (engine sensing and monitoring, air/fuel ratio control, ignition timing, and detonation control) into one comprehensive engine control system for optimum performance and reliability.

The NO_x emissions from the engine are minimized using lean-burn combustion technology. Lean-burn combustion refers to a high level of excess air (generally 50% to 100% relative to the stoichiometric amount) in the combustion chamber. The excess air absorbs heat during the combustion process, thereby reducing the combustion temperature and pressure and resulting in lower NO_x emissions.

Detailed operating data are provided in Appendix C.

3.3 MATERIALS PROCESSED

The engine fuel is exclusively natural gas, as defined in 40 CFR §72.2. Recent natural gas sample analyses indicate a fuel composition of approximately 96% methane, 2% ethane, 0.1% nitrogen, and 1.5% carbon dioxide.

3.4 RATED CAPACITY

EUEMERGGEN has a maximum output of approximately 1,818 horsepower. At this achievable output, the heat input rating is approximately 12.8 mmBtu/hr. However, the maximum achievable operating condition of the engine is constrained by site and pipeline specific conditions.

3.5 PROCESS INSTRUMENTATION

During testing, the following engine operating parameters were monitored and collected:

- Date and Time
- Engine brake horsepower (HP)
- Engine speed (RPM)
- Electrical output (kW)
- Engine Load as Max kW (% max)
- Amps
- Fuel gas flow (scf/hr)
- Total engine operating time (hr)

The horsepower of the engine will be calculated based on the following:

$$1 \text{ kilowatt (kW)} = 1.35962 \text{ Horsepower (HP)}$$

During testing of EUEMERGGEN the process data was recorded in 15-minute increments using manual readings of field instrumentation. Refer to Appendix C for this operating data.

4.0 SAMPLING AND ANALYTICAL PROCEDURES

Triplicate one-hour test runs for NO_x, CO, VOC, and O₂ concentrations were conducted using the USEPA test methods in Table 4-1. The sampling and analytical procedures associated with each parameter are described further in the following sections.

**Table 4-1
Test Methods**

Parameter	Method	USEPA Title
Sample traverses	1	Sample and Velocity Traverses for Stationary Sources
Oxygen	3A	Determination of Oxygen and Carbon Dioxide Concentrations in Emissions from Stationary Sources (Instrumental Analyzer Procedure)
Moisture content	4/Alt-008	Determination of Moisture Content in Stack Gases
Nitrogen oxides	7E	Determination of Nitrogen Oxides Emissions from Stationary Sources (Instrumental Analyzer Procedure)
Carbon monoxide	10	Determination of Carbon Monoxide Emissions from Stationary Sources (Instrumental Analyzer Procedure)
Emission rates	19	Sulfur Dioxide Removal and Particulate, Sulfur Dioxide and Nitrogen Oxides from Electric Utility Steam Generators
Volatile organic compounds	25A	Determination of Total Gaseous Organic Concentration Using a Flame Ionization Analyzer

4.1 DESCRIPTION OF SAMPLING TRAIN AND FIELD PROCEDURES

The test matrix in Table 4-2 summarizes the sampling and analytical methods performed during this test program.

**Table 4-2
Test Matrix**

Date (2023)	Run	Sample Type	Start Time (EST)	Stop Time (EST)	Test Duration (min)	EPA Test Method	Comment
EUEMERGEN							
February 22	1	O ₂ NO _x CO CH ₄ VOC	10:20	11:19	60	1 3A 4(alt-008) 7E 10 19 25A	3-points located in each duct at 16.7, 50.0 & 83.3 % of the measurement line were traversed
	2		11:52	12:51	60		
	3		13:31	14:39*	60		
*NO _x analyzer pump failed, run was paused while issue was resolved.							

4.2 SAMPLE LOCATION AND TRAVERSE POINTS (USEPA METHOD 1)

The number and location of traverse points for each engine was evaluated according to the requirements in Table 2 of 40 CFR Part 60, Subpart JJJJ, and USEPA Method 1, *Sample and Velocity Traverses for Stationary Sources*.

The engine is equipped with sample ports located downstream (Post) of the oxidation catalyst.

Post-catalyst Sampling Ports

Two test ports are in a 14-inch vertical exhaust stack exiting the engine. The sampling ports are situated:

- Approximately 309-inches or 22.1 duct diameters downstream of a flow disturbance where the engine exhaust makes a 90-degree turn, and
- Approximately 63.5-inches or 4.5 duct diameters upstream of the stack exit.

The sample ports are 1-inch in diameter and extend 3 inches beyond the stack wall.

Because the ducts are >12 inches in diameter and the sampling port locations meet the two and half-diameter criterion of Section 11.1.1 of Method 1 of 40 CFR Part 60, Appendix A-1, the duct was sampled at 3 traverse points located at 16.7, 50.0, and 83.3% of the measurement line ('3-point long line'). The flue gas was sampled from the three traverse points at approximately equal intervals during the tests. Refer to Figure 4-1 for engine diagram and sampling location.

Figure 4-1. EUEMERGGEN Caterpillar Model G3512B Engine Diagram

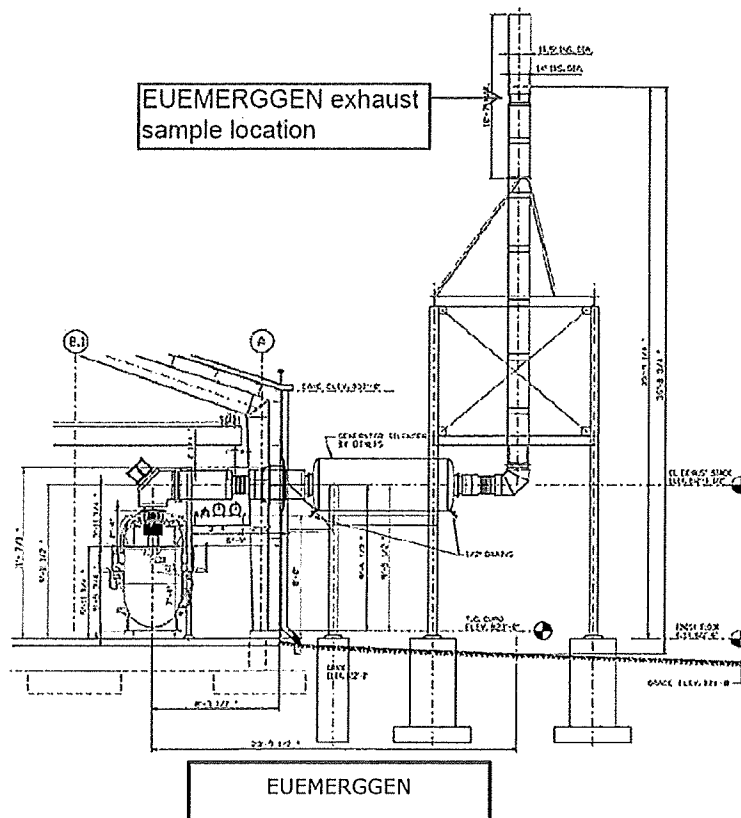

4.3 MOISTURE CONTENT (USEPA ALT-008)

Exhaust gas moisture content was determined in accordance with USEPA ALT-008, *Alternative Moisture Measurement Method Midget Impingers*, an alternative method for correcting pollutant concentration data to appropriate moisture conditions (e.g., pollutant and/or air flow data on a dry or wet basis) validated May 19, 1993, by the USEPA Emission Measurement Branch. The procedure is incorporated into Method 6A of 40 CFR Part 60 and is based on field validation tests described in *An Alternative Method for Stack Gas Moisture Determination* (Jon Stanley, Peter Westlin, 1978, USEPA Emissions Measurement Branch). The sample apparatus configuration follows the general guidelines contained in Figure 4-2 and § 8.2 of USEPA Method 4, *Determination of Moisture Content in Stack Gases*, and ALT-008 Figure 1 or 2. The flue gas is withdrawn from the stack at a constant rate through a heated sample probe, umbilical, four midget impingers, and a metering console with pump. The moisture is removed from the gas stream in the ice-bath chilled impingers and determined gravimetrically. Refer to Figure 4-2 for a figure of the Alternative Method 008 Moisture Sample Apparatus.

Figure 4-2. Alternative Method 008 Moisture Sample Apparatus

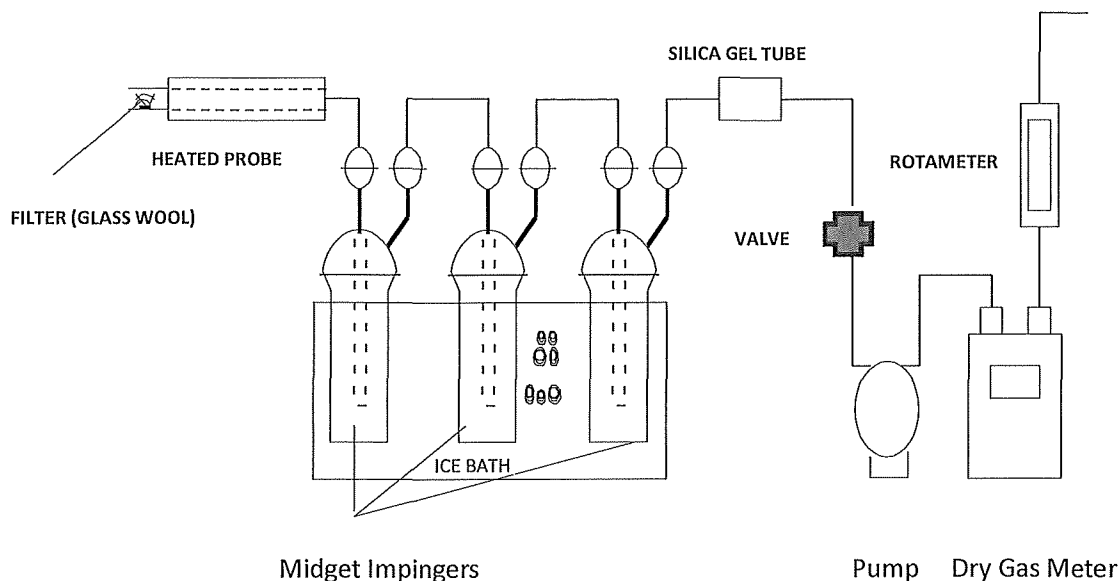

The silica gel tube depicted in this figure was replaced with a midget impinger (bubbler) with a straight tube insert, as allowed in ALT-008, §1

4.4 O₂, NO_x, AND CO (USEPA METHODS 3A, 7E, AND 10)

Oxygen, nitrogen oxides, and carbon monoxide concentrations were measured using the following sampling and analytical procedures:

- USEPA Method 3A, *Determination of Oxygen and Carbon Dioxide Concentrations in Emissions from Stationary Sources (Instrumental Analyzer Procedure)*,
- USEPA Method 7E, *Determination of Nitrogen Oxides Emissions from Stationary Sources (Instrumental Analyzer Procedure)*, and
- USEPA Method 10, *Determination of Carbon Monoxide Emissions from Stationary Sources (Instrumental Analyzer Procedure)*.

Each cited method sampling is procedurally similar except for the analyzer and analytical technique used. Engine exhaust gas was extracted from the stack or ducts through a stainless-steel probe, heated Teflon® sample line, and through a gas conditioning system to remove water and dry the sample before entering a sample pump, flow control manifold, and gas analyzers.

Figure 4-3 depicts a drawing of the Methods 3A, 7E, and 10 sampling system.

Figure 4-3. USEPA Methods 3A, 7E, and 10 Sampling System

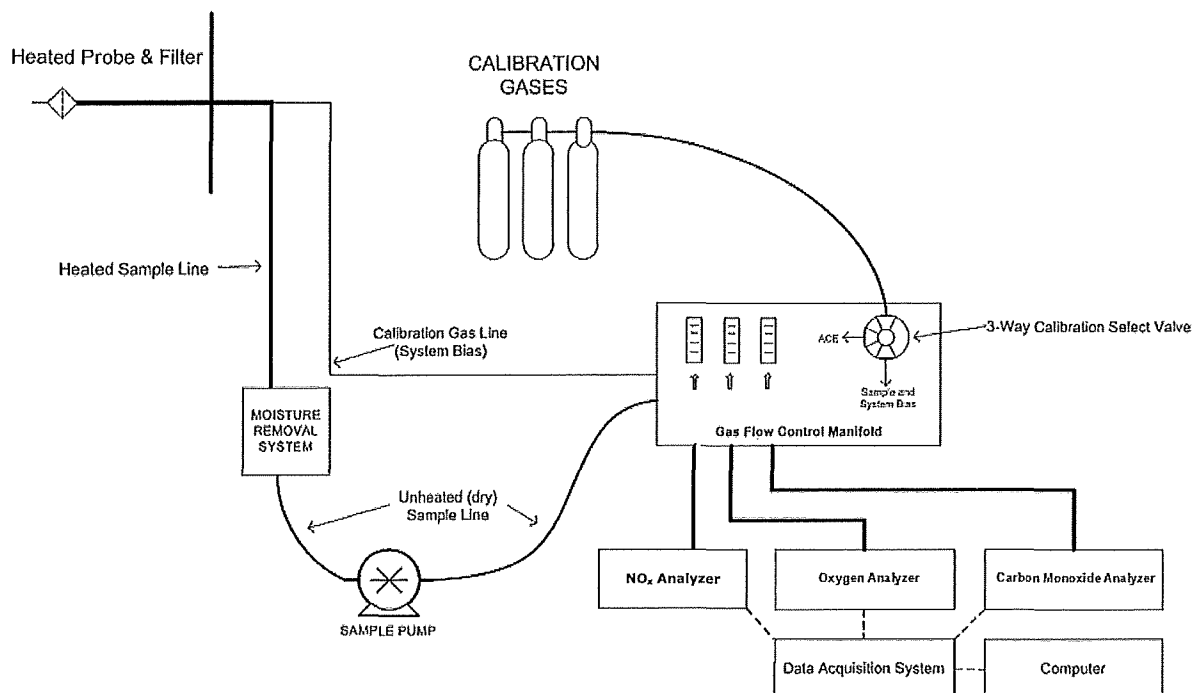

Prior to sampling engine exhaust gas, the analyzers are calibrated by performing a calibration error test where zero-, mid-, and high-level calibration gases are introduced directly to the back of the analyzers. The calibration error check is performed to evaluate if the analyzers response was within $\pm 2.0\%$ of the calibration gas span or high calibration gas concentration. An initial system-bias test is then performed where the zero- and mid- or high- calibration gases are introduced at the sample probe to measure the ability of the system to respond accurately to within $\pm 5.0\%$ of span.

A NO₂ to NO conversion efficiency test is performed on the NO_x analyzer prior to beginning the test program to evaluate the ability of the instrument to convert NO₂ to NO before analyzing for NO_x.

Upon successful completion of the calibration error and initial system bias tests, sample flow rate and component temperatures are verified, and the probes inserted into the ducts at the appropriate traverse point. After confirming the engine is operating at established conditions, the test run is initiated. Gas concentrations are recorded at 1-minute intervals throughout each 60-minute test run. Oxygen concentrations are measured to adjust the pollutant concentrations to 15% O₂ and calculate pollutant emission rates.

At the conclusion of each test run, a post-test system bias check is performed to compare analyzer bias and drift relative to pre-test system bias checks, ensuring analyzer bias is within $\pm 5.0\%$ of span and drift is within $\pm 3.0\%$. The analyzer response is also used to correct measured gas concentrations for analyzer drift.

For the analyzer calibration error tests, bias tests and drift checks, these evaluations are also passed if the standard criteria are not achieved, but the absolute difference between the analyzer responses and calibration gas is less than or equal to 0.5 ppmv for NO_x and CO or 0.5% for O₂.

4.5 EMISSION RATES (USEPA METHOD 19)

USEPA Method 19, *Determination of Sulfur Dioxide Removal Efficiency and Particulate Matter, Sulfur Dioxide, and Nitrogen Oxide Emission Rates*, was used to calculate a fuel specific F factor and exhaust gas flowrate.

A fuel sample was collected during testing and analyzed by gas chromatography, ultraviolet fluorescence, and electronic sensing cells to obtain hydrocarbons, non-hydrocarbons, heating value, and other parameters of the natural gas samples. The results were used to calculate F_w and F_d factors (ratios of combustion gas volumes to heat inputs) using USEPA Method 19 Equations 19-13, 19-14, and 19-15. This F_d factor was then used to calculate the emission flow rate with the corresponding equation presented in Figure 4-4. The flow rate was used in calculations to present emissions in units of g/HP-hr, which is presented in Figure 4-5.

Figure 4-4. USEPA Method 19 Emission Flow Rate Equation

$$Q_s = F_d H \frac{20.9}{20.9 - O_2}$$

Where:

- Q_s = stack flow rate (dscf/min)
- F_d = fuel-specific oxygen-based F factor, dry basis, from Method 19 (dscf/mmBtu)
- H = fuel heat input rate, (mmBtu/min), at the higher heating value (HHV) measured at engine fuel feed line, calculated as (fuel feed rate in ft³/min) x (fuel heat content in mmBtu/ft³)
- O_2 = stack oxygen concentration, dry basis (%)

Figure 4-5. 40 CFR Part 60 Subpart JJJJ Equation 1, 2, 3

$$ER = \frac{Cd \times K \times Q \times T}{HP - hr}$$

Where:

- ER = Emission rate of pollutant in g/HP-hr
- Cd = Measured pollutant concentration in parts per million by volume, dry basis (ppmvd)
- K = Conversion constant for ppm pollutant to grams per standard cubic meter at 20°C:
 - KNOx = 1.912x10⁻³
 - KCO = 1.164x10⁻³
 - KVOC = 1.833x10⁻³
- Q = Stack gas volumetric flow rate, in cubic meter per hour, dry basis
- T = Time of test run, in hours

4.6 VOLATILE ORGANIC COMPOUNDS (USEPA METHOD 25A)

VOC concentrations were measured from each engine using a Thermo Model 55i Direct Methane and Non-methane Analyzer following the guidelines of USEPA Method 25A, *Determination of Total Gaseous Organic Concentration Using a Flame Ionization Analyzer (FIA)*. The instrument uses a flame ionization detector (FID) to measure the exhaust gas total hydrocarbon concentration in conjunction with a gas chromatography column that separates methane from other organic compounds.

The components of the extractive sample interface apparatus are constructed of Type 316 stainless steel and Teflon. Flue gas was sampled from the stack via a sample probe and

heated sample line and into the analyzer, which communicates with data acquisition handling systems (DAHS) via output signal cables. The analyzer uses a rotary valve and gas chromatograph column to separate methane from hydrocarbons in the sample and quantifies these components using a flame ionization detector.

Sample gas is injected into the column and due to methane's low molecular weight and high volatility, the compound moves through the column more quickly than other organic compounds that may be present and is quantified by the FID. The column is then flushed with inert carrier gas and the remaining non-methane organic compounds are analyzed in the FID. This analytical technique allows separate measurements for methane and non-methane organic compounds via the use of a single FID. Refer to Figure 4-6 for a drawing of the USEPA Method 25A sampling apparatus.

The field VOC instrument was calibrated with zero air and three propane and methane in air calibration gases following USEPA Method 25A procedures at the zero level, low (25 to 35 percent of calibration span), mid (45 to 55 percent of calibration span) and high (equivalent to 80 to 90 percent of instrument span). Note that the field VOC instrument measures on a wet basis, therefore measured exhaust gas moisture content was used to convert wet basis VOC concentrations to dry and calculate VOC mass emission rates.

Figure 4-6. USEPA Method 25A Sample Apparatus

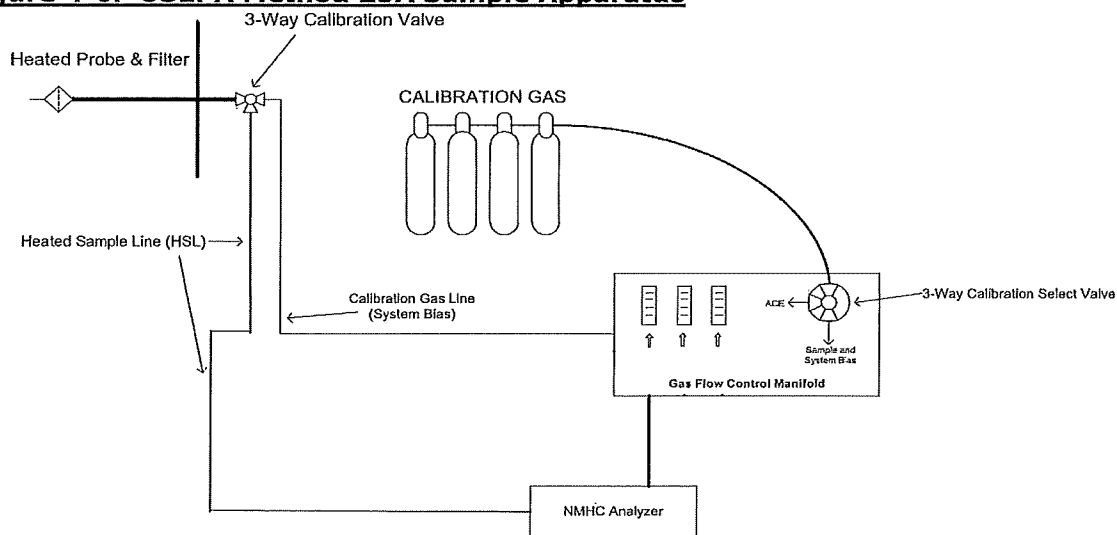

5.0 TEST RESULTS AND DISCUSSION

The test program conducted February 22, 2023, satisfies the performance testing and compliance evaluation requirements in 40 CFR Part 60, Subpart JJJJ, "Standards of Performance for Stationary Spark Ignition Internal Combustion Engines."

5.1 TABULATION OF RESULTS

The results of the testing indicate EUENGINE1 is compliant with the applicable NO_x, CO, and VOC emissions limits and associated operating requirements as summarized in Table 2-1. Appendix Table 1 contains detailed tabulation of results, process operating conditions, and exhaust gas conditions.

5.2 SIGNIFICANCE OF RESULTS

The results of the testing indicate compliance with the applicable emission limits.

5.3 VARIATIONS FROM SAMPLING OR OPERATING CONDITIONS

No sampling or operating condition variations occurred during the test event.

5.4 AIR POLLUTION CONTROL DEVICE MAINTENANCE

Other than routine maintenance, no major air pollution control device maintenance was performed during the three-month period prior to the test event. Engine optimization is continuously performed to ensure lean-burn combustion and ongoing compliance with regulatory emission limits.

5.5 RE-TEST DISCUSSION

Based on the results of this test program, a re-test is not required. Subsequent air emissions testing on the engine will be performed:

- every 8,760 engine operating hours or 3 years (2026), whichever is first. The engine operating hours at the conclusion of testing were 351 hours.

5.6 RESULTS OF AUDIT SAMPLES

Audit samples for the reference methods utilized during this test program are not available from USEPA Stationary Source Audit Sample Program providers. The USEPA reference methods performed state reliable results are obtained by persons equipped with a thorough knowledge of the techniques associated with each method. Factors with the potential to cause measurement errors are minimized by implementing quality control (QC) and assurance (QA) programs into the applicable components of field testing. QA/QC components were included in this test program. Table 5-1 summarizes the primary field quality assurance and quality control activities that were performed. Refer to Appendix E for supporting documentation.

Table 5-1
QA/QC Procedures

QA/QC Activity	Purpose	Procedure	Frequency	Acceptance Criteria
M1: Sampling Location	Evaluates suitability of sampling location	Measure distance from ports to downstream and upstream flow disturbances	Pre-test	≥2 diameters downstream; ≥0.5 diameter upstream.
M1: Duct diameter/dimensions	Verifies area of stack is accurately measured	Review as-built drawings and field measurement	Pre-test	Field measurement agreement with as-built drawings
M4 (ALT-008): Field balance calibration	Verify moisture measurement accuracy	Use Class 6 weight to check balance accuracy	Daily before use	The field balance must measure the weight within ±0.5 gram of the certified mass
M3A, M7E, M10, M25A: Calibration gas standards	Ensures accurate calibration standards	Traceability protocol of calibration gases	Pre-test	Calibration gas uncertainty ≤2.0%

**Table 5-1
QA/QC Procedures**

QA/QC Activity	Purpose	Procedure	Frequency	Acceptance Criteria
M3A, M7E, M10: Calibration Error	Evaluates analyzer operation	Calibration gases introduced directly into analyzers	Pre-test	±2.0% of span or ≤0.5 ppmv or ≤0.5 % abs. difference
M3A, M7E, M10: System Bias and Analyzer Drift	Evaluates analyzer/sample system integrity and accuracy over test duration	Calibration gas introduced at sample probe tip, HSL, and into analyzers	Pre-test and Post-test	Bias: ±5.0% of span Drift: ±3.0% of span or ≤ 0.5 ppmv or 0.5% abs. difference
M7E: NO ₂ -NO converter efficiency	Evaluates NO ₂ -NO converter operation	NO ₂ gas introduced directly into analyzer	Pre-test or Post-test	NO _x response ≤2% drop from peak value observed
M25A: Calibration Error	Evaluates analyzer and sample system operation	Calibration gases introduced through sample system	Pre-test	±5.0% of the calibration gas value
M25A: Zero and Calibration Drift	Evaluates analyzer/sample system integrity and accuracy over test duration	Calibration gases introduced through sample system	Pre-test and Post-test	±3.0% of the analyzer calibration span

5.7 CALIBRATION SHEETS

Calibration sheets, including gas protocol sheets and analyzer quality control and assurance checks are presented in Appendix D.

5.8 SAMPLE CALCULATIONS

Sample calculations and formulas used to compute emissions data are presented in Appendix A.

5.9 FIELD DATA SHEETS

Field data sheets are presented in Appendix B.

5.10 LABORATORY QUALITY ASSURANCE / QUALITY CONTROL PROCEDURES

The method specific quality assurance and quality control procedures in each method employed during this test program were followed, without deviation. Refer to Appendix D for the laboratory data sheets associated with the natural gas fuel samples collected during the test program.

5.11 QA/QC BLANKS

The Method 3A, 7E, 10, and 25A calibration gases described in Table 5-1 above were the only QA/QC media employed during the test event. QA/QC data are shown in Appendix D.