

RECEIVED

JUN 01 2023

AIR QUALITY DIVISION

**Source Test Report for  
2023 Part 60 PEMS RATA Testing**

**Boilers (EUBOILER1, EUBOILER2, EUBOILER3)  
Turbines (EUCTG1, EUCTG2, EUCTG3)**

**Dearborn Industrial Generation, LLC  
Dearborn, Michigan**

**Prepared For:**

**Dearborn Industrial Generation, LLC  
2400 Miller Road  
Dearborn, MI 48121**

**Prepared By:**

**Montrose Air Quality Services, LLC  
4949 Fernlee Avenue  
Royal Oak, MI 48073**

**For Submission To:**

**Michigan Department of Environment, Great Lakes, & Energy  
525 West Allegan Street  
Lansing, MI 48933-1502**

**Document Number: MW049AS-026145-RT-1225**

**Test Dates: March 20-24, 2023**

**Submittal Date: May 23, 2023**



*Nu631-test2-20230320*

### Test Results Summary - Boilers

	Boiler 1100	Boiler 2100	Boiler 3100
<b>Source ID Number:</b>	EUBOILER1	EUBOILER2	EUBOILER3
<b>Control Device:</b>	NA	NA	NA
<b>Sampling Location:</b>	Exhaust	Exhaust	Exhaust
<b>Operating Load:</b>	High/Normal	High/Normal	High/Normal
<b>Permit Number:</b>	EGLE PTI No. 163-17, MI-ROP-N6631-2012a		
<b>NO<sub>x</sub> Emission Rate RA (lb/MMBtu):</b>	0.0005	0.0002	0.0015
Part 60, PS- 16 Criteria Used	NA *	NA *	NA *
<b>SO<sub>2</sub> Emission Rate RA (lb/MMBtu):</b>	4.55	13.0	8.37
Part 60, PS- 16 Criteria Used	≤ 20%	≤ 20%	≤ 20%
<b>CO Concentration RA (ppmvd):</b>	0.66	0.72	1.30
Part 60, PS- 16 Criteria Used	≤ 2 ppmvd	≤ 2 ppmvd	≤ 2 ppmvd
<b>O<sub>2</sub> Concentration RA (%):</b>	0.24	0.040	0.022
Part 60, PS- 16 Criteria Used	≤ 1% O <sub>2</sub>	≤ 1% O <sub>2</sub>	≤ 1% O <sub>2</sub>

\* RA not applicable because emissions were <0.05 lb/MMBtu. See Section 4.2 for details.

### Test Results Summary - Turbines

	Turbine 1100	Turbine 2100	Turbine 3100
<b>Source ID Number:</b>	EUCTG1	EUCTG2	EUCTG3
<b>Control Device:</b>	NA	NA	NA
<b>Sampling Location:</b>	Exhaust	Exhaust	Exhaust
<b>Operating Load:</b>	High/Normal	High/Normal	High/Normal
<b>Permit Number:</b>	EGLE PTI Nos. 8-17 and 163-17, MI-ROP-N6631-2012a		
<b>NO<sub>x</sub> Emission Rate RA (lb/MMBtu):</b>	0.0013	0.0004	0.0002
Part 60, PS- 16 Criteria Used	NA *	NA *	NA *
<b>NO<sub>x</sub> Concentration RA (ppmvd at 15% O<sub>2</sub>):</b>	0.39	0.21	0.12
Part 60, PS- 16 Criteria Used	≤ 2 ppmvd	≤ 2 ppmvd	≤ 2 ppmvd
<b>CO Concentration RA (ppmvd):</b>	1.38	0.21	0.83
Part 60, PS- 16 Criteria Used	≤ 2 ppmvd	≤ 2 ppmvd	≤ 2 ppmvd
<b>O<sub>2</sub> Concentration RA (%):</b>	0.29	0.088	0.10
Part 60, PS- 16 Criteria Used	≤ 1% O <sub>2</sub>	≤ 1% O <sub>2</sub>	≤ 1% O <sub>2</sub>

\* RA not applicable because emissions were <0.05 lb/MMBtu. See Section 4.2 for details.

## Review and Certification

All work, calculations, and other activities and tasks performed and presented in this document were carried out by me or under my direction and supervision. I hereby certify that, to the best of my knowledge, Montrose operated in conformance with the requirements of the Montrose Quality Management System and ASTM D7036-04 during this test project.

**Signature:** John Nestor **Date:** 05 / 22 / 2023

**Name:** John Nestor **Title:** District Manager

I have reviewed, technically and editorially, details, calculations, results, conclusions, and other appropriate written materials contained herein. I hereby certify that, to the best of my knowledge, the presented material is authentic, accurate, and conforms to the requirements of the Montrose Quality Management System and ASTM D7036-04.

**Signature:** robert j lisy jr **Date:** 05 / 22 / 2023

**Name:** Robert J. Lisy, Jr. **Title:** Reporting Hub Manager

## Table of Contents

<u>Section</u>	<u>Page</u>
1.0 Introduction .....	8
1.1 Summary of Test Program .....	8
1.2 Key Personnel.....	13
2.0 Plant and Sampling Location Descriptions .....	15
2.1 Process Description, Operation, and Control Equipment .....	15
2.1.1 Boilers 1100, 2100, and 3100 .....	15
2.1.2 Turbine 1100 .....	15
2.1.3 Turbines 2100 and 3100.....	15
2.2 Facility PEMS and Reference Method (RM) CEMS Descriptions.....	16
2.3 Flue Gas Sampling Location.....	17
2.4 Operating Conditions and Process Data.....	18
3.0 Sampling and Analytical Procedures .....	19
3.1 Test Methods.....	19
3.1.1 EPA Method 3A.....	19
3.1.2 EPA Method 6C.....	19
3.1.3 EPA Method 7E.....	19
3.1.4 EPA Method 10 .....	19
3.1.5 EPA Method 19 .....	20
3.1.6 EPA Performance Specification 2.....	21
3.1.7 EPA Performance Specification 3.....	22
3.1.8 EPA Performance Specification 4A.....	22
3.1.9 EPA Performance Specification 16 .....	22
3.2 Process Test Methods .....	22
4.0 Test Discussion and Results .....	23
4.1 Field Test Deviations and Exceptions .....	23
4.2 Presentation of Results .....	23
5.0 Internal QA/QC Activities .....	48
5.1 QA/QC Audits .....	48

5.2	QA/QC Discussion .....	48
5.3	Quality Statement .....	49

## List of Appendices

A	Field Data and Calculations .....	50
	A.1 Sampling Locations.....	51
	A.2 EUBOILER1 Data Sheets.....	66
	A.3 EUBOILER2 Data Sheets.....	81
	A.4 EUBOILER3 Data Sheets.....	96
	A.5 EUCTG1 Data Sheets .....	111
	A.6 EUCTG2 Data Sheets .....	120
	A.7 EUCTG3 Data Sheets .....	129
	A.8 EUBOILER 1-Instrumental Test Method Data.....	138
	A.9 EUBOILER2-Instrumental Test Method Data.....	151
	A.10 EUBOILER3-Instrumental Test Method Data .....	164
	A.11 EUCTG1-Instrumental Test Method Data.....	177
	A.12 EUCTG2-Instrumental Test Method Data.....	188
	A.13 EUCTG3-Instrumental Test Method Data.....	199
	A.14 Example Calculations .....	210
B	Facility PEMS/Process Data .....	215
	B.1 EUBOILER1-Facility PEMS Data .....	216
	B.2 EUBOILER2-Facility PEMS Data .....	229
	B.3 EUBOILER3-Facility PEMS Data .....	242
	B.4 EUCTG1-Facility PEMS Data .....	255
	B.5 EUCTG2-Facility PEMS Data .....	266
	B.6 EUCTG3-Facility PEMS Data .....	277
C	Quality Assurance/Quality Control.....	288
	C.1 Units and Abbreviations .....	289
	C.2 Instrumental Test Method QA/QC Data .....	298
	C.3 Accreditation Information/Certifications.....	425
D	Regulatory Information .....	430

D.1 Regulatory Correspondence.....	431
D.2 Test Plan.....	434

## List of Tables

1-1 Summary of Boiler Test Program .....	9
1-2 Summary of Turbine Test Program .....	9
1-3 Summary of Part 60 PEMS RATA Results – EUBOILER1 PEMS .....	10
1-4 Summary of Part 60 PEMS RATA Results – EUBOILER2 PEMS .....	11
1-5 Summary of Part 60 PEMS RATA Results – EUBOILER3 PEMS .....	11
1-6 Summary of Part 60 PEMS RATA Results – EUCTG1 PEMS .....	12
1-7 Summary of Part 60 PEMS RATA Results – EUCTG2 PEMS .....	12
1-8 Summary of Part 60 PEMS RATA Results – EUCTG3 PEMS .....	13
1-9 Test Personnel and Observers .....	14
2-1 Facility PEMS Information - Boilers.....	16
2-2 Facility PEMS Information - Turbines .....	16
2-3 RM CEMS Information .....	16
2-4 Boiler Sampling Locations.....	17
2-5 Turbine Sampling Locations .....	17
4-1 NO <sub>x</sub> (lb/MMBtu) RATA Results EUBOILER1 .....	24
4-2 SO <sub>2</sub> (lb/MMBtu) RATA Results EUBOILER1.....	25
4-3 CO (ppmvd) RATA Results EUBOILER1 .....	26
4-4 O <sub>2</sub> (%-Dry) RATA Results EUBOILER1 .....	27
4-5 NO <sub>x</sub> (lb/MMBtu) RATA Results EUBOILER2 .....	28
4-6 SO <sub>2</sub> (lb/MMBtu) RATA Results EUBOILER2.....	29
4-7 CO (ppmvd) RATA Results EUBOILER2 .....	30
4-8 O <sub>2</sub> (%-Dry) RATA Results EUBOILER2 .....	31
4-9 NO <sub>x</sub> (lb/MMBtu) RATA Results EUBOILER3 .....	32
4-10 SO <sub>2</sub> (lb/MMBtu) RATA Results EUBOILER3.....	33
4-11 CO (ppmvd) RATA Results EUBOILER3 .....	34
4-12 O <sub>2</sub> (%-Dry) RATA Results EUBOILER3 .....	35
4-13 NO <sub>x</sub> (lb/MMBtu) RATA Results EUCTG1 .....	36

RECEIVED

JUN 01 2023

AIR QUALITY DIVISION

4-14 NO <sub>x</sub> (ppmvd corrected to 15% O <sub>2</sub> ) RATA Results EUCTG1 .....	37
4-15 CO (ppmvd) RATA Results EUCTG1 .....	38
4-16 O <sub>2</sub> (%-Dry) RATA Results EUCTG1 .....	39
4-17 NO <sub>x</sub> (lb/MMBtu) RATA Results EUCTG2 .....	40
4-18 NO <sub>x</sub> (ppmvd corrected to 15% O <sub>2</sub> ) RATA Results EUCTG2 .....	41
4-19 CO (ppmvd) RATA Results EUCTG2 .....	42
4-20 O <sub>2</sub> (%-Dry) RATA Results EUCTG2 .....	43
4-21 NO <sub>x</sub> (lb/MMBtu) RATA Results EUCTG3 .....	44
4-22 NO <sub>x</sub> (ppmvd corrected to 15% O <sub>2</sub> ) RATA Results EUCTG3 .....	45
4-23 CO (ppmvd) RATA Results EUCTG3 .....	46
4-24 O <sub>2</sub> (%-Dry) RATA Results EUCTG3 .....	47
5-1 Part 60 Gas Cylinder Information.....	48

## List of Figures

3-1 EPA Methods 3A, 6C, 7E, and 10 Sampling Train .....	20
3-2 EPA Methods 3A, 7E, and 10 Sampling Train .....	21

## 1.0 Introduction

### 1.1 Summary of Test Program

Dearborn Industrial Generation, LLC (DIG) contracted Montrose Air Quality Services, LLC (Montrose) to perform the Annual Quality Assurance (QA) Relative Accuracy Test Audit (RATA) for the Predictive Emission Monitoring Systems (PEMS) associated with the Boilers 1100 (EUBOILER1), 2100 (EUBOILER2), and 3100 (EUBOILER3) and Turbines 1100 (EUCTG1), 2100 (EUCTG2), and 3100 (EUCTG3) at the DIG facility (State Registration Number: N6631) located in Dearborn, Michigan. Testing was performed on March 20-24, 2023, for the purpose of satisfying the emission testing requirements pursuant to Michigan Department of Environment, Great Lakes, and Energy (EGLE) Renewable Operation Permit No. MI-ROP-N6631-2012a and Permit-to-Install (PTI) Nos. 8-17 and 163-17 by evaluating the quality of the emissions data produced by DIG's PEMS in accordance with 40 CFR Part 60, Appendices B and F.

The specific objectives were to:

- Verify the relative accuracy (RA) of the EUBOILER1 PEMS, EUBOILER2 PEMS, and EUBOILER3 PEMS for nitrogen oxides (NO<sub>x</sub>) emissions (lb/MMBtu) (as NO<sub>2</sub>), sulfur dioxide (SO<sub>2</sub>) emissions (lb/MMBtu), carbon monoxide (CO) concentration (ppmvd), and oxygen (O<sub>2</sub>) concentration (%-Dry) in accordance with Performance Specifications 2 (PS-2), 3 (PS-3), 4A (PS-4A), and 16 (PS-16)
- Verify the relative accuracy (RA) of the EUCTG1 PEMS, EUCTG2 PEMS, and EUCTG3 PEMS for NO<sub>x</sub> emissions (lb/MMBtu) (as NO<sub>2</sub>), NO<sub>x</sub> concentration (ppmvd corrected to 15% O<sub>2</sub>), CO concentration (ppmvd), and O<sub>2</sub> concentration (%-Dry) in accordance with PS-2, PS-3, PS-4A, and PS-16
- Conduct the test program with a focus on safety



Montrose performed the tests to measure the emission parameters listed in Tables 1-1 and 1-2.

**Table 1-1  
Summary of Boiler Test Program**

Test Date(s)	Unit ID/ Source Name	Activity/ Parameters	Test Methods	No. of Runs	Duration (Minutes)
3/23/2023	EUBOILER1	O <sub>2</sub>	EPA 3A	11	21
3/23/2023	EUBOILER1	SO <sub>2</sub>	EPA 6C	11	21
3/23/2023	EUBOILER1	NO <sub>x</sub>	EPA 7E	11	21
3/23/2023	EUBOILER1	CO	EPA 10	11	21
3/24/2023	EUBOILER2	O <sub>2</sub>	EPA 3A	11	21
3/24/2023	EUBOILER2	SO <sub>2</sub>	EPA 6C	11	21
3/24/2023	EUBOILER2	NO <sub>x</sub>	EPA 7E	11	21
3/24/2023	EUBOILER2	CO	EPA 10	11	21
3/22/2023-3/23/2023	EUBOILER3	O <sub>2</sub>	EPA 3A	11	21
3/22/2023-3/23/2023	EUBOILER3	SO <sub>2</sub>	EPA 6C	11	21
3/22/2023-3/23/2023	EUBOILER3	NO <sub>x</sub>	EPA 7E	11	21
3/22/2023-3/23/2023	EUBOILER3	CO	EPA 10	11	21

**Table 1-2  
Summary of Turbine Test Program**

Test Date(s)	Unit ID/ Source Name	Activity/ Parameters	Test Methods	No. of Runs	Duration (Minutes)
3/20/2023	EUCTG1	O <sub>2</sub>	EPA 3A	10	21
3/20/2023	EUCTG1	NO <sub>x</sub>	EPA 7E	10	21
3/20/2023	EUCTG1	CO	EPA 10	10	21
3/20/2023	EUCTG2	O <sub>2</sub>	EPA 3A	10	21
3/20/2023	EUCTG2	NO <sub>x</sub>	EPA 7E	10	21
3/20/2023	EUCTG2	CO	EPA 10	10	21
3/21/2023	EUCTG3	O <sub>2</sub>	EPA 3A	10	21
3/21/2023	EUCTG3	NO <sub>x</sub>	EPA 7E	10	21
3/21/2023	EUCTG3	CO	EPA 10	X	21

For the Part 60 PEMS RATA, nine RATA runs were used to determine the RA of the EUBOILER1 PEMS, EUBOILER2 PEMS, EUBOILER3 PEMS, EUCTG1 PEMS, EUCTG2 PEMS, and EUCTG3 PEMS.

To simplify this report, a list of Units and Abbreviations is included in Appendix C.1. Throughout this report, chemical nomenclature, acronyms, and reporting units are not defined. Please refer to the list for specific details.

This report presents the test results and supporting data, descriptions of the testing procedures, descriptions of the facility and sampling locations, and a summary of the quality assurance procedures used by Montrose. The RA test results are summarized and compared to their respective regulatory requirements in Tables 1-3 through 1-8. Detailed results for individual test runs can be found in Section 4.0. All supporting data can be found in the appendices.

The testing was conducted by the Montrose personnel listed in Table 1-9. The tests were conducted according to the test plan (protocol) dated February 15, 2023, that was submitted to and approved by the EGLE.

**Table 1-3  
Summary of Part 60 PEMS RATA Results – EUBOILER1 PEMS**

**March 23, 2023**

Parameter/Units	Regulatory Reference	RA	Allowable
<b>Part 60</b>			
<b>Oxygen (O<sub>2</sub>)</b>			
% volume dry	PS-16	0.24	≤ 1.0% O <sub>2</sub>
<b>Sulfur Dioxide (SO<sub>2</sub>)</b>			
lb/MMBtu	PS-16	4.55	≤ 20% of RM
<b>Nitrogen Oxides (NO<sub>x</sub>)</b>			
lb/MMBtu (as NO <sub>2</sub> )	PS-16	0.0005	NA *
<b>Carbon Monoxide (CO)</b>			
ppmvd	PS-16	0.66	≤ 2 ppmvd CO

\* RA is not applicable because emissions were ≤0.05 lb/MMBtu. See Section 4.2 for details.

**Table 1-4**  
**Summary of Part 60 PEMS RATA Results – EUBOILER2 PEMS**  
**March 24, 2023**

Parameter/Units	Regulatory Reference	RA	Allowable
<b>Part 60</b>			
<b>Oxygen (O<sub>2</sub>)</b>			
% volume dry	PS-16	0.040	≤ 1.0% O <sub>2</sub>
<b>Sulfur Dioxide (SO<sub>2</sub>)</b>			
lb/MMBtu	PS-16	13.0	≤ 20% of RM
<b>Nitrogen Oxides (NO<sub>x</sub>)</b>			
lb/MMBtu (as NO <sub>2</sub> )	PS-16	0.0002	NA *
<b>Carbon Monoxide (CO)</b>			
ppmvd	PS-16	0.72	≤ 2 ppmvd CO

\* RA is not applicable because emissions were ≤0.05 lb/MMBtu. See Section 4.2 for details.

**Table 1-5**  
**Summary of Part 60 PEMS RATA Results – EUBOILER3 PEMS**  
**March 22-23, 2023**

Parameter/Units	Regulatory Reference	RA	Allowable
<b>Part 60</b>			
<b>Oxygen (O<sub>2</sub>)</b>			
% volume dry	PS-16	0.022	≤ 1.0% O <sub>2</sub>
<b>Sulfur Dioxide (SO<sub>2</sub>)</b>			
lb/MMBtu	PS-16	8.37	≤ 20% of RM
<b>Nitrogen Oxides (NO<sub>x</sub>)</b>			
lb/MMBtu (as NO <sub>2</sub> )	PS-16	0.0015	NA *
<b>Carbon Monoxide (CO)</b>			
ppmvd	PS-16	1.30	≤ 2 ppmvd CO

\* RA is not applicable because emissions were ≤0.05 lb/MMBtu. See Section 4.2 for details.

**Table 1-6**  
**Summary of Part 60 PEMS RATA Results – EUCTG1 PEMS**  
**March 20, 2023**

Parameter/Units	Regulatory Reference	RA	Allowable
<b>Part 60</b>			
<b>Oxygen (O<sub>2</sub>)</b>			
% volume dry	PS-16	0.29	≤ 1.0% O <sub>2</sub>
<b>Nitrogen Oxides (NO<sub>x</sub>)</b>			
ppmvd @ 15% O <sub>2</sub>	PS-16	0.39	≤ 2 ppmvd NO <sub>x</sub>
lb/MMBtu (as NO <sub>2</sub> )	PS-16	0.0013	NA *
<b>Carbon Monoxide (CO)</b>			
ppmvd	PS-16	1.38	≤ 2 ppmvd CO

\* RA is not applicable because emissions were ≤0.05 lb/MMBtu. See Section 4.2 for details.

**Table 1-7**  
**Summary of Part 60 PEMS RATA Results – EUCTG2 PEMS**  
**March 20, 2023**

Parameter/Units	Regulatory Reference	RA	Allowable
<b>Part 60</b>			
<b>Oxygen (O<sub>2</sub>)</b>			
% volume dry	PS-16	0.088	≤ 1.0% O <sub>2</sub>
<b>Nitrogen Oxides (NO<sub>x</sub>)</b>			
ppmvd @ 15% O <sub>2</sub>	PS-16	0.21	≤ 2 ppmvd NO <sub>x</sub>
lb/MMBtu (as NO <sub>2</sub> )	PS-16	0.0004	NA *
<b>Carbon Monoxide (CO)</b>			
ppmvd	PS-16	0.21	≤ 2 ppmvd CO

\* RA is not applicable because emissions were ≤0.05 lb/MMBtu. See Section 4.2 for details.

**Table 1-8**  
**Summary of Part 60 PEMS RATA Results – EUCTG3 PEMS**  
**March 21, 2023**

Parameter/Units	Regulatory Reference	RA	Allowable
<b>Part 60</b>			
<b>Oxygen (O<sub>2</sub>)</b>			
% volume dry	PS-16	0.10	≤ 1.0% O <sub>2</sub>
<b>Nitrogen Oxides (NO<sub>x</sub>)</b>			
ppmvd @ 15% O <sub>2</sub>	PS-16	0.12	≤ 2 ppmvd NO <sub>x</sub>
lb/MMBtu (as NO <sub>2</sub> )	PS-16	0.0002	NA *
<b>Carbon Monoxide (CO)</b>			
ppmvd	PS-16	0.83	≤ 2 ppmvd CO

\* RA is not applicable because emissions were ≤0.05 lb/MMBtu. See Section 4.2 for details.

## 1.2 Key Personnel

A list of project participants is included below:

### Facility Information

Source Dearborn Industrial Generation, LLC  
 Location: 2400 Miller Road  
 Dearborn, MI 48121

Project Theon Heisserer Kathryn Cunningham  
 Contact: Environmental Manager Environmental Support  
 Role: Environmental Manager DIG  
 Company: DIG 517-768-3462  
 Telephone: 313-336-7189 Ext. 250  
 Email: Theon.HeissererIV@cmsenergy.com Kathryn.cunningham@cmsenergy.com

### Agency Information

Regulatory EGLE  
 Agency: TPU Supervisor  
 Agency TPU Supervisor  
 Contact:  
 Telephone: 517-335-3122  
 Email: --



**Testing Company Information**

Testing Firm: Montrose Air Quality Services, LLC  
Contact: John Nestor  
Title: District Manager  
Telephone: 248-548-8070  
Email: jonestor@montrose-env.com

Robert J. Lisy, Jr.  
Reporting Hub Manager  
440-262-3760  
rlisy@montrose-env.com

**Subcontractor Information**

Company: CMC Solutions, Inc.  
Contact: Brian Swanson  
Telephone: 248-960-1632  
Email: bswanson@cmcsolutions.org

Test personnel and observers are summarized in Table 1-9.

**Table 1-9  
Test Personnel and Observers**

Name	Affiliation	Role/Responsibility
John Nestor	Montrose	District Manager, QI
Shane Rabideau	Montrose	Field Technician
Theon Heisserer	DIG	Test Coordinator
Andrew Riley	EGLE	Observer

## 2.0 Plant and Sampling Location Descriptions

### 2.1 Process Description, Operation, and Control Equipment

The DIG facility operates three boilers (Boiler 1100 (EUBOILER1), Boiler 2100 (EUBOILER2), and Boiler 3100 (EUBOILER3)) and three combustion turbines (Turbine 1100 (EUCTG1), Turbine 2100 (EUCTG2), and Turbine 3100 (EUCTG3)).

#### 2.1.1 Boilers 1100, 2100, and 3100

The EUBOILER1, EUBOILER 2, and EUBOILER3 boilers are nominally rated at an output capacity of 500,000 lb/hr of superheated steam at a minimum pressure of 1,350 psig and temperature of 960°F. The input capacity of the boilers while firing natural gas (NG) and blast furnace gas (BFG) is 746 MMBtu/hr, and the BFG to NG ratio is approximately 90% to 10%. The boilers typically operate under co-firing conditions, rarely operating under NG only conditions; therefore, the RATA testing was performed under the co-firing conditions only. The steam from each boiler is dispatched to a steam turbine for electrical generation. Low-NO<sub>x</sub> combustors minimize the emissions of NO<sub>x</sub> from the boilers.

#### 2.1.2 Turbine 1100

The EUCTG1 simple-cycle turbine is nominally rated at an output capacity of 181 Megawatts (MW) with a heat input of 1,638 MMBtu/hr. Low-NO<sub>x</sub> combustors minimize the emissions of NO<sub>x</sub> from the turbine, while the emissions of CO and SO<sub>2</sub> are minimized by the efficient combustion of low sulfur bearing clean-burning fuels.

#### 2.1.3 Turbines 2100 and 3100

The EUCTG2 and EUCTG3 combined-cycle turbines are nominally rated at an output of 179 MW with a heat input of 1,626 MMBtu/hr. NG is used as the primary fuel. The combined-cycle turbine generators consist of a compressor, combustion turbine, and generator. Energy is generated at the combustion turbine by drawing in ambient air by means of burning fuel and expanding the hot combustion gases in a three-stage turbine. Hot exhaust gases from the combustion turbine are directed to a multi-pressure heat recovery steam generator (HRSG) to produce steam. Low-NO<sub>x</sub> combustors minimize the emissions of NO<sub>x</sub> from the turbines, while the emissions of CO and SO<sub>2</sub> are minimized by the efficient combustion of low sulfur bearing clean-burning fuels.

Turbines 1100, 2100, and 3100 are each fired exclusively with pipeline quality natural gas.

RECEIVED

JUN 01 2023

AIR QUALITY DIVISION

## 2.2 Facility PEMS and Reference Method (RM) CEMS Descriptions

The Facility PEMS information is presented in Tables 2-1 and 2-2, and the RM CEMS analyzer information is presented in Table 2-3.

**Table 2-1  
Facility PEMS Information - Boilers**

PEMS ID	Measurement Type	Manufacturer	Model No.	Serial No.
EUBOILER1 PEMS	O <sub>2</sub> , SO <sub>2</sub> , NO <sub>x</sub> , CO	CMC Solutions	SmartCEMS®-75	DIG.BL1100.256738
EUBOILER2 PEMS	O <sub>2</sub> , SO <sub>2</sub> , NO <sub>x</sub> , CO	CMC Solutions	SmartCEMS®-75	DIG.BL2100.256738
EUBOILER3 PEMS	O <sub>2</sub> , SO <sub>2</sub> , NO <sub>x</sub> , CO	CMC Solutions	SmartCEMS®-75	DIG.BL3100.256738

**Table 2-2  
Facility PEMS Information - Turbines**

PEMS ID	Measurement Type	Manufacturer	Model No.	Serial No.
EUCTG1 PEMS	O <sub>2</sub> , NO <sub>x</sub> , CO	CMC Solutions	SmartCEMS®-75	DIG.GT1100.97341
EUCTG2 PEMS	O <sub>2</sub> , NO <sub>x</sub> , CO	CMC Solutions	SmartCEMS®-75	DIG.GT2100.52081
EUCTG3 PEMS	O <sub>2</sub> , NO <sub>x</sub> , CO	CMC Solutions	SmartCEMS®-75	DIG.GT3100.52081

**Table 2-3  
RM CEMS Information**

Analyzer Type	Manufacturer	Model No.	Serial No.	Range
O <sub>2</sub>	Teledyne	T802	197	0-19.91%
SO <sub>2</sub>	BOVAR	721-M	VW-721M-8562-1	0-90.78 ppm
NO <sub>x</sub>	Teledyne	T200H	727	0-91.39 ppm
CO	Teledyne	T300M	97	0-90.41 ppm



## 2.3 Flue Gas Sampling Location

Information regarding the sampling location is presented in Tables 2-4 and 2-5.

**Table 2-4  
Boiler Sampling Locations**

Sampling Location	Stack Inside Diameter (in.)	Distance from Nearest Disturbance		Number of Traverse Points
		Downstream EPA "B" (in./dia.)	Upstream EPA "A" (in./dia.)	
EUBOILER1 Exhaust	126.0	1,680 / 13.3	480 / 3.8	Gaseous: 3
EUBOILER2 Exhaust	126.0	1,680 / 13.3	480 / 3.8	Gaseous: 3
EUBOILER3 Exhaust	126.0	1,680 / 13.3	480 / 3.8	Gaseous: 3

**Table 2-5  
Turbine Sampling Locations**

Sampling Location	Stack Inside Diameter (in.)	Distance from Nearest Disturbance		Number of Traverse Points
		Downstream EPA "B" (in./dia.)	Upstream EPA "A" (in./dia.)	
EUCTG1 Exhaust	228.0 X 264.0	720 / 2.9	240 / 1.0	Gaseous: 3
EUCTG2 Exhaust	210.0	1,200 / 5.7	360 / 1.7	Gaseous: 3
EUCTG3 Exhaust	210.0	1,200 / 5.7	360 / 1.7	Gaseous: 3

See Appendix A.1 for more information.

## 2.4 Operating Conditions and Process Data

The PEMS RATAs were performed while the boilers and turbines were operating at normal high load conditions.

Plant personnel were responsible for establishing the test conditions and collecting all applicable unit-operating data. The Facility PEMS and process data that was provided is presented in Appendix B. Data collected includes the following parameters:

- Facility Boiler PEMS data for each 21-minute RATA run
- Facility Turbine PEMS data for each 21-minute RATA run
- Boiler steam load, klb/hr
- Boiler mixed fuel F-Factor, dscf/MMBtu
- Turbine load, MW

## 3.0 Sampling and Analytical Procedures

### 3.1 Test Methods

The test methods for this test program have been presented in Table 1-1. Additional information regarding specific applications or modifications to standard procedures is presented below.

#### 3.1.1 EPA Method 3A, Determination of Oxygen and Carbon Dioxide in Emissions from Stationary Sources (Instrumental Analyzer Procedure)

EPA Method 3A is an instrumental test method used to measure the concentration of O<sub>2</sub> and CO<sub>2</sub> in stack gas. The effluent gas is continuously or intermittently sampled and conveyed to analyzers that measure the concentrations of O<sub>2</sub> and CO<sub>2</sub>. The performance requirements of the method must be met to validate data.

The typical sampling system is detailed in Figures 3-1 and 3-2.

#### 3.1.2 EPA Method 6C, Determination of Sulfur Dioxide Emissions from Stationary Sources (Instrumental Analyzer Procedure)

EPA Method 6C is an instrumental test method used to continuously measure emissions of SO<sub>2</sub>. Conditioned gas is sent to an analyzer to measure the concentration of SO<sub>2</sub>. The performance requirements of the method must be met to validate the data.

The typical sampling system is detailed in Figure 3-1.

#### 3.1.3 EPA Method 7E, Determination of Nitrogen Oxides Emissions from Stationary Sources (Instrumental Analyzer Procedure)

EPA Method 7E is an instrumental test method used to continuously measure emissions of NO<sub>x</sub> as NO<sub>2</sub>. Conditioned gas is sent to an analyzer to measure the concentration of NO<sub>x</sub>. NO and NO<sub>2</sub> can be measured separately or simultaneously together but, for the purposes of this method, NO<sub>x</sub> is the sum of NO and NO<sub>2</sub>. The performance requirements of the method must be met to validate the data.

The typical sampling system is detailed in Figures 3-1 and 3-2.

#### 3.1.4 EPA Method 10, Determination of Carbon Monoxide Emissions from Stationary Sources (Instrumental Analyzer Procedure)

EPA Method 10 is an instrumental test method used to continuously measure emissions of CO. Conditioned gas is sent to an analyzer to measure the concentration of CO. The performance requirements of the method must be met to validate the data.

The typical sampling system is detailed in Figures 3-1 and 3-2.

**Figure 3-1**  
**EPA Methods 3A, 6C, 7E, and 10 Sampling Train**

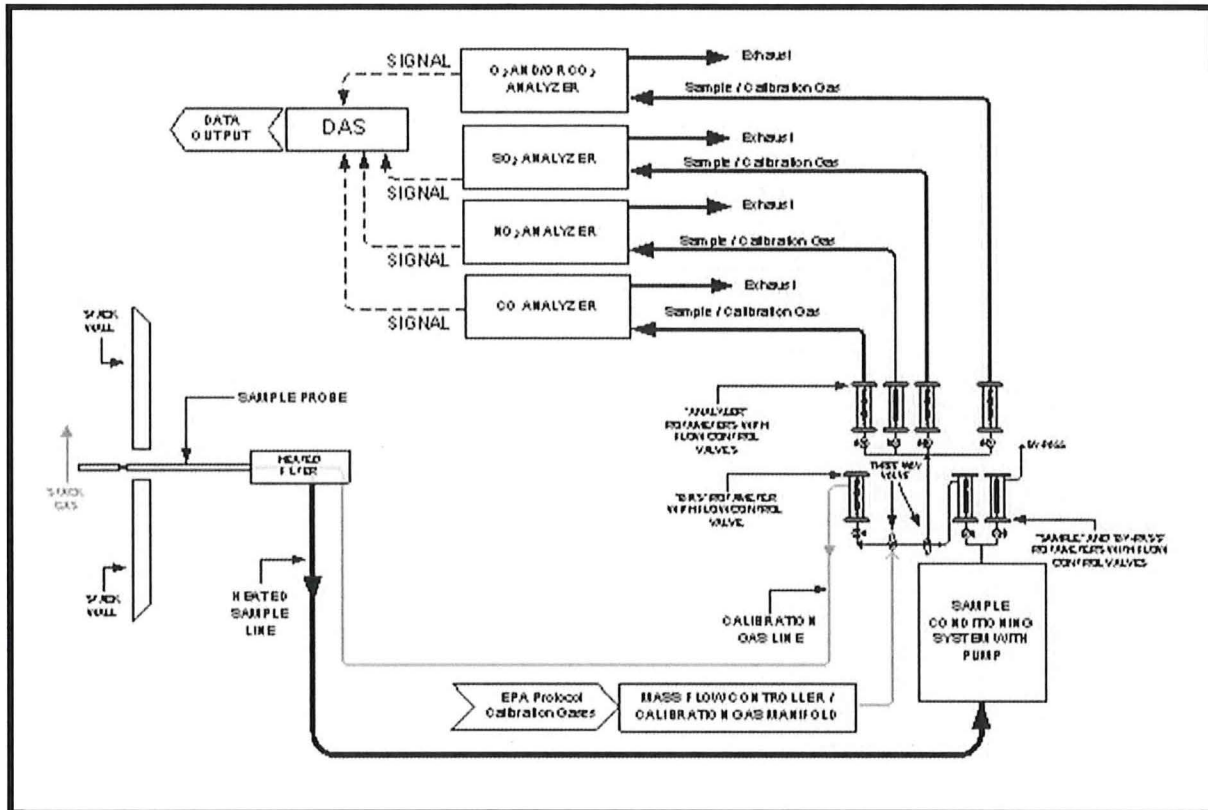

### 3.1.5 EPA Method 19, Measurement of Sulfur Dioxide Removal Efficiency and Particulate Matter, Sulfur Dioxide, and Nitrogen Oxide Emission Rates

EPA Method 19 is a manual method used to determine (a) PM, SO<sub>2</sub>, and NO<sub>x</sub> emission rates; (b) sulfur removal efficiencies of fuel pretreatment and SO<sub>2</sub> control devices; and (c) overall reduction of potential SO<sub>2</sub> emissions. This method provides data reduction procedures, but does not include any sample collection or analysis procedures.

EPA Method 19 is used to calculate mass emission rates in units of lb/MMBtu. EPA Method 19, Table 19-2 contains a list of assigned fuel factors for different types of fuels, which can be used for these calculations.

**Figure 3-2**  
**EPA Methods 3A, 7E, and 10 Sampling Train**

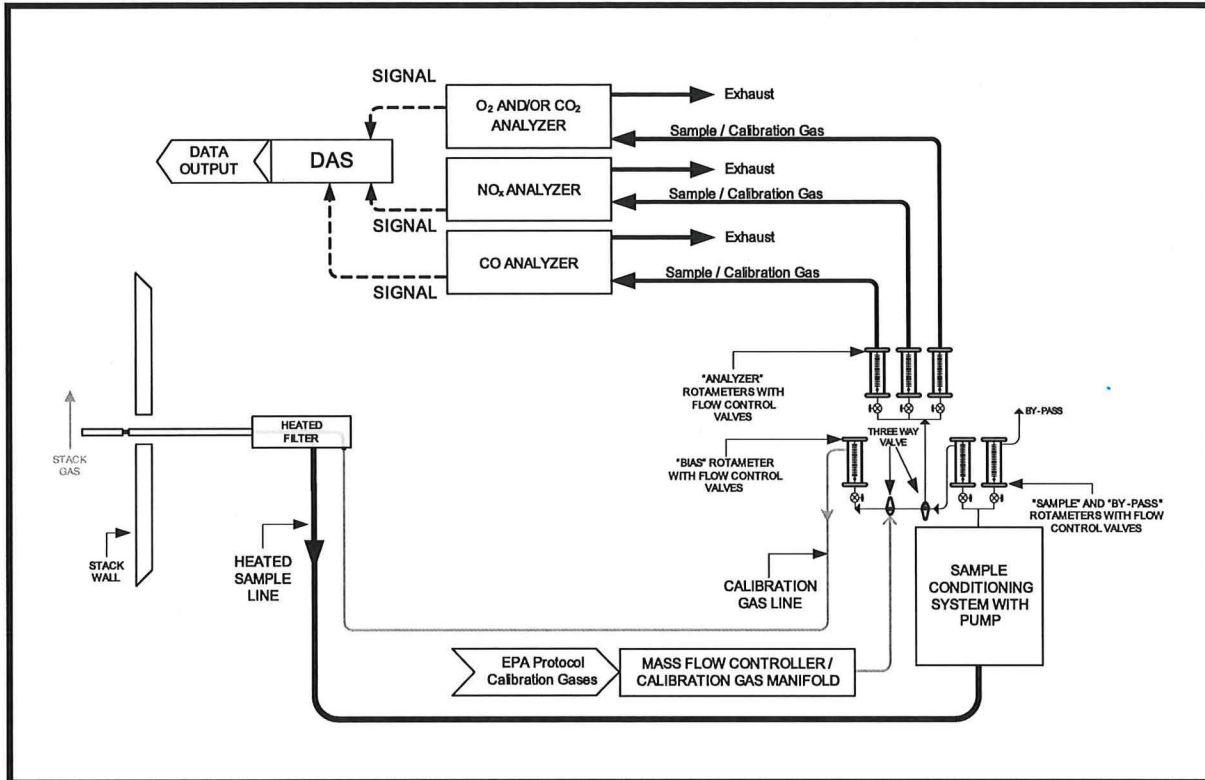

### 3.1.6 EPA Performance Specification 2, Specifications and Test Procedures for SO<sub>2</sub> and NO<sub>x</sub> Continuous Emission Monitoring Systems in Stationary Sources

EPA Performance Specification 2 is a specification used to evaluate the acceptability of SO<sub>2</sub> and NO<sub>x</sub> CEMS. The evaluation is conducted at the time of installation or soon after, and whenever specified in the regulations. The CEMS may include, for certain stationary sources, a diluent (O<sub>2</sub> or CO<sub>2</sub>) monitor. The RA and CD tests are conducted to determine conformance of the CEMS to the specification.

### **3.1.7 EPA Performance Specification 3, Specifications and Test Procedures for O<sub>2</sub> and CO<sub>2</sub> Continuous Monitoring Systems in Stationary Sources**

EPA Performance Specification 3 is a specification used to evaluate the acceptability of O<sub>2</sub> and CO<sub>2</sub> CEMS. The evaluation is conducted at the time of installation or soon after, and whenever specified in the regulations. This specification applies to O<sub>2</sub> or CO<sub>2</sub> monitors that are not included under PS-2. The RA and CD tests are conducted to determine conformance of the CEMS to the specification.

### **3.1.8 EPA Performance Specification 4A, Specifications and Test Procedures for Carbon Monoxide Continuous Emission Monitoring Systems in Stationary Sources**

EPA Performance Specification 4A is a specification used to evaluate the acceptability of CO CEMS. The evaluation is conducted at the time of installation or soon after, and whenever specified in the regulations. This specification was developed primarily for CEMS that comply with low emission standards (less than 200 ppmv). The RA and CD tests are conducted to determine conformance of the CEMS to the specification.

### **3.1.9 EPA Performance Specification 16, Specifications and Test Procedures for Predictive Emission Monitoring Systems in Stationary Sources**

EPA Performance Specification 16 is a specification used to evaluate the acceptability of Predictive Emission Monitoring Systems (PEMS) to show compliance with an emission limitation under 40 CFR 60, 61, or 63. These procedures are used to certify a PEMS after initial installation and periodically thereafter to ensure the system is operating properly and meets the requirements of all applicable regulations. Ongoing QA/QC tests include sensor evaluation, bias correction, quarterly Relative Accuracy Audits (RAA), and annual Relative Accuracy Test Audits (RATA).

## **3.2 Process Test Methods**

The test plan did not require that process samples be collected during this test program; therefore, no process sample data are presented in this test report.

## 4.0 Test Discussion and Results

### 4.1 Field Test Deviations and Exceptions

No field deviations or exceptions from the test plan or test methods occurred during this test program.

### 4.2 Presentation of Results

The RA results are compared to the regulatory requirements in Tables 1-3 through 1-8. The results of individual test runs performed are presented in Tables 4-1 through 4-24. Emissions are reported in units consistent with those in the applicable regulations or requirements. Additional information is included in the appendices as presented in the Table of Contents.

Since the NO<sub>x</sub> emissions displayed in Tables 4-1, 4-5, 4-9, 4-13, 4-17, and 4-21 were below 0.05 lb/MMBtu, the lb/MMBtu RA is not applicable under PS-16. The NO<sub>x</sub> lb/MMBtu data in their respective tables are displayed for informational purposes only.

**Table 4-1  
NO<sub>x</sub> (lb/MMBtu) RATA Results  
EUBOILER1**

Run No.	Date	Time	RM	PEMS*	Difference	Run used (Y/N)	Steam Load (klb/hr)
1	3/23/2023	11:50-12:11	0.0198	0.0200	-0.0002	Y	213.7
2	3/23/2023	12:25-12:46	0.0222	0.0240	-0.0018	Y	187.4
3	3/23/2023	13:00-13:21	0.0202	0.0240	-0.0038	N	198.8
4	3/23/2023	13:40-14:01	0.0238	0.0270	-0.0032	N	191.9
5	3/23/2023	14:15-14:36	0.0251	0.0250	0.0001	Y	183.4
6	3/23/2023	14:55-15:16	0.0225	0.0250	-0.0025	Y	193.9
7	3/23/2023	15:35-15:56	0.0217	0.0220	-0.0003	Y	178.4
8	3/23/2023	16:10-16:31	0.0226	0.0230	-0.0004	Y	176.2
9	3/23/2023	16:45-17:06	0.0224	0.0230	-0.0006	Y	177.1
10	3/23/2023	17:35-17:56	0.0222	0.0220	0.0002	Y	189.9
11	3/23/2023	18:10-18:31	0.0237	0.0230	0.0007	Y	188.4
Averages			0.0225	0.0230	-0.0005		187.6
Unit Load			Normal				
RA† based on   mean difference			0.0005	lb/MMBtu as NO <sub>x</sub>			

\* PEMS data provided by CMC Solutions, LLC.

† RA not applicable because emissions were <0.05 lb/MMBtu.



**Table 4-2**  
**SO<sub>2</sub> (lb/MMBtu) RATA Results**  
**EUBOILER1**

Run No.	Date	Time	RM	PEMS*	Difference	Run used (Y/N)	Steam Load (klb/hr)
1	3/23/2023	11:50-12:11	0.176	0.162	0.014	N	213.7
2	3/23/2023	12:25-12:46	0.195	0.195	0.000	Y	187.4
3	3/23/2023	13:00-13:21	0.196	0.190	0.006	Y	198.8
4	3/23/2023	13:40-14:01	0.197	0.186	0.011	Y	191.9
5	3/23/2023	14:15-14:36	0.176	0.185	-0.009	Y	183.4
6	3/23/2023	14:55-15:16	0.167	0.188	-0.021	N	193.9
7	3/23/2023	15:35-15:56	0.194	0.193	0.001	Y	178.4
8	3/23/2023	16:10-16:31	0.190	0.198	-0.008	Y	176.2
9	3/23/2023	16:45-17:06	0.192	0.195	-0.003	Y	177.1
10	3/23/2023	17:35-17:56	0.209	0.196	0.013	Y	189.9
11	3/23/2023	18:10-18:31	0.206	0.195	0.011	Y	188.4
Averages			0.195	0.193	0.003		185.7
Standard Deviation			0.0083				
Confidence Coefficient (CC)			0.0064				
Unit Load			Normal				
RA based on mean RM value			4.55	%			

\* PEMS data provided by CMC Solutions, LLC.

**Table 4-3  
CO (ppmvd) RATA Results  
EUBOILER1**

Run No.	Date	Time	RM	PEMS*	Difference	Run used (Y/N)	Steam Load (klb/hr)
1	3/23/2023	11:50-12:11	-0.495	0.141	-0.636	Y	213.7
2	3/23/2023	12:25-12:46	-0.487	0.322	-0.809	Y	187.4
3	3/23/2023	13:00-13:21	-0.498	0.182	-0.680	Y	198.8
4	3/23/2023	13:40-14:01	-0.373	0.230	-0.603	Y	191.9
5	3/23/2023	14:15-14:36	-0.325	0.221	-0.546	Y	183.4
6	3/23/2023	14:55-15:16	-0.357	0.199	-0.556	Y	193.9
7	3/23/2023	15:35-15:56	-0.604	0.243	-0.847	N	178.4
8	3/23/2023	16:10-16:31	-0.372	0.265	-0.637	Y	176.2
9	3/23/2023	16:45-17:06	-0.491	0.205	-0.696	Y	177.1
10	3/23/2023	17:35-17:56	-0.580	0.238	-0.818	N	189.9
11	3/23/2023	18:10-18:31	-0.485	0.269	-0.754	Y	188.4
Averages			-0.0432	0.226	-0.658		190.1
Unit Load			Normal				
RA based on   mean difference			0.66	ppmvd as CO			

\* PEMS data provided by CMC Solutions, LLC.

**Table 4-4**  
**O<sub>2</sub> (%-Dry) RATA Results**  
**EUBOILER1**

Run No.	Date	Time	RM	PEMS*	Difference	Run used (Y/N)	Steam Load (klb/hr)
1	3/23/2023	11:50-12:11	3.888	3.941	-0.053	Y	213.7
2	3/23/2023	12:25-12:46	3.925	3.453	0.472	N	187.4
3	3/23/2023	13:00-13:21	3.964	3.710	0.254	Y	198.8
4	3/23/2023	13:40-14:01	4.044	3.620	0.424	Y	191.9
5	3/23/2023	14:15-14:36	4.155	3.632	0.523	N	183.4
6	3/23/2023	14:55-15:16	3.781	3.701	0.080	Y	193.9
7	3/23/2023	15:35-15:56	3.586	3.528	0.058	Y	178.4
8	3/23/2023	16:10-16:31	4.059	3.703	0.356	Y	176.2
9	3/23/2023	16:45-17:06	4.020	3.803	0.217	Y	177.1
10	3/23/2023	17:35-17:56	4.204	3.773	0.431	Y	189.9
11	3/23/2023	18:10-18:31	4.128	3.734	0.394	Y	188.4
Averages			3.964	3.724	0.240		189.8
Unit Load			Normal				
RA based on   mean difference			0.24	% as O <sub>2</sub>			

\* PEMS data provided by CMC Solutions, LLC.

**Table 4-5**  
**NO<sub>x</sub> (lb/MMBtu) RATA Results**  
**EUBOILER2**

Run No.	Date	Time	RM	PEMS*	Difference	Run used (Y/N)	Steam Load (klb/hr)
1	3/24/2023	7:45-8:06	0.0194	0.0220	-0.0026	N	175.9
2	3/24/2023	8:20-8:41	0.0189	0.0200	-0.0011	Y	176.2
3	3/24/2023	8:55-9:16	0.0191	0.0200	-0.0009	Y	145.7
4	3/24/2023	9:35-9:56	0.0203	0.0200	0.0003	Y	125.7
5	3/24/2023	10:15-10:36	0.0212	0.0190	0.0022	Y	171.1
6	3/24/2023	10:55-11:16	0.0201	0.0200	0.0001	Y	185.4
7	3/24/2023	11:30-11:51	0.0199	0.0200	-0.0001	Y	156.9
8	3/24/2023	12:05-12:26	0.0194	0.0200	-0.0006	Y	168.5
9	3/24/2023	12:45-13:06	0.0185	0.0200	-0.0015	Y	176.4
10	3/24/2023	13:20-13:41	0.0187	0.0190	-0.0003	Y	165.9
11	3/24/2023	13:55-14:16	0.0230	0.0200	0.0030	N	177.2
Averages			0.0196	0.0198	-0.0002		163.5
Unit Load			Normal				
RA† based on   mean difference			0.0002	lb/MMBtu as NO <sub>x</sub>			

\* PEMS data provided by CMC Solutions, LLC.

† RA not applicable because emissions were <0.05 lb/MMBtu.

RECEIVED

JUN 01 2023

AIR QUALITY DIVISION

**Table 4-6**  
**SO<sub>2</sub> (lb/MMBtu) RATA Results**  
**EUBOILER2**

Run No.	Date	Time	RM	PEMS*	Difference	Run used (Y/N)	Steam Load (klb/hr)
1	3/24/2023	7:45-8:06	0.099	0.105	-0.006	Y	175.9
2	3/24/2023	8:20-8:41	0.113	0.102	0.011	Y	176.2
3	3/24/2023	8:55-9:16	0.112	0.099	0.013	Y	145.7
4	3/24/2023	9:35-9:56	0.120	0.098	0.022	N	125.7
5	3/24/2023	10:15-10:36	0.114	0.101	0.013	Y	171.1
6	3/24/2023	10:55-11:16	0.132	0.134	-0.002	Y	185.4
7	3/24/2023	11:30-11:51	0.138	0.138	0.000	Y	156.9
8	3/24/2023	12:05-12:26	0.118	0.100	0.018	Y	168.5
9	3/24/2023	12:45-13:06	0.122	0.100	0.022	Y	176.4
10	3/24/2023	13:20-13:41	0.161	0.113	0.048	N	165.9
11	3/24/2023	13:55-14:16	0.120	0.119	0.001	Y	177.2
Averages			0.119	0.111	0.008		170.4
Standard Deviation			0.0099				
Confidence Coefficient (CC)			0.0076				
Unit Load			Normal				
RA based on mean RM value			13.0	%			

\* PEMS data provided by CMC Solutions, LLC.

**Table 4-7**  
**CO (ppmvd) RATA Results**  
**EUBOILER2**

Run No.	Date	Time	RM	PEMS*	Difference	Run used (Y/N)	Steam Load (klb/hr)
1	3/24/2023	7:45-8:06	-0.541	0.418	-0.959	N	175.9
2	3/24/2023	8:20-8:41	-0.350	0.398	-0.748	Y	176.2
3	3/24/2023	8:55-9:16	-0.518	0.370	-0.888	Y	145.7
4	3/24/2023	9:35-9:56	-0.454	0.319	-0.773	Y	125.7
5	3/24/2023	10:15-10:36	-0.447	0.461	-0.908	N	171.1
6	3/24/2023	10:55-11:16	-0.237	0.377	-0.614	Y	185.4
7	3/24/2023	11:30-11:51	-0.340	0.402	-0.742	Y	156.9
8	3/24/2023	12:05-12:26	-0.407	0.365	-0.772	Y	168.5
9	3/24/2023	12:45-13:06	-0.228	0.366	-0.594	Y	176.4
10	3/24/2023	13:20-13:41	-0.409	0.384	-0.793	Y	165.9
11	3/24/2023	13:55-14:16	-0.158	0.359	-0.517	Y	177.2
Averages			-0.345	0.371	-0.716		164.2
Unit Load			Normal				
RA based on   mean difference			0.72	ppmvd as CO			

\* PEMS data provided by CMC Solutions, LLC.

**Table 4-8**  
**O<sub>2</sub> (%-Dry) RATA Results**  
**EUBOILER2**

Run No.	Date	Time	RM	PEMS*	Difference	Run used (Y/N)	Steam Load (klb/hr)
1	3/24/2023	7:45-8:06	4.414	4.862	-0.448	N	175.9
2	3/24/2023	8:20-8:41	4.589	4.534	0.055	Y	176.2
3	3/24/2023	8:55-9:16	4.641	4.596	0.045	Y	145.7
4	3/24/2023	9:35-9:56	4.661	4.636	0.025	Y	125.7
5	3/24/2023	10:15-10:36	4.451	4.473	-0.022	Y	171.1
6	3/24/2023	10:55-11:16	4.542	4.522	0.020	Y	185.4
7	3/24/2023	11:30-11:51	4.514	4.587	-0.073	Y	156.9
8	3/24/2023	12:05-12:26	4.661	4.469	0.192	Y	168.5
9	3/24/2023	12:45-13:06	4.639	4.495	0.144	Y	176.4
10	3/24/2023	13:20-13:41	4.783	4.462	0.321	N	165.9
11	3/24/2023	13:55-14:16	4.503	4.526	-0.023	Y	177.2
Averages			4.578	4.538	0.040		164.8
Unit Load			Normal				
RA based on   mean difference			0.040	% as O <sub>2</sub>			

\* PEMS data provided by CMC Solutions, LLC.

**Table 4-9**  
**NO<sub>x</sub> (lb/MMBtu) RATA Results**  
**EUBOILER3**

Run No.	Date	Time	RM	PEMS*	Difference	Run used (Y/N)	Steam Load (klb/hr)
1	3/22/2023	10:10-10:31	0.0255	0.0230	0.0025	Y	195.8
2	3/22/2023	11:30-11:51	0.0274	0.0240	0.0034	Y	186.4
3	3/22/2023	12:05-12:26	0.0288	0.0240	0.0048	Y	191.3
4	3/22/2023	13:15-13:36	0.0283	0.0230	0.0053	N	184.5
5	3/22/2023	13:55-14:16	0.0268	0.0270	-0.0002	Y	189.0
6	3/22/2023	14:35-14:56	0.0284	0.0340	-0.0056	N	188.1
7	3/22/2023	15:30-15:51	0.0276	0.0290	-0.0014	Y	188.8
8	3/23/2023	7:30-7:51	0.0232	0.0220	0.0012	Y	241.6
9	3/23/2023	8:05-8:26	0.0220	0.0200	0.0020	Y	241.0
10	3/23/2023	8:45-9:06	0.0222	0.0200	0.0022	Y	241.6
11	3/23/2023	9:20-9:41	0.0191	0.0200	-0.0009	Y	240.0
Averages			0.0248	0.0232	0.0015		212.8
Unit Load			Normal				
RA† based on   mean difference			0.0015	lb/MMBtu as NO <sub>x</sub>			

\* PEMS data provided by CMC Solutions, LLC.

† RA not applicable because emissions were <0.05 lb/MMBtu.



**Table 4-10**  
**SO<sub>2</sub> (lb/MMBtu) RATA Results**  
**EUBOILER3**

Run No.	Date	Time	RM	PEMS*	Difference	Run used (Y/N)	Steam Load (klb/hr)
1	3/22/2023	10:10-10:31	0.140	0.146	-0.006	Y	195.8
2	3/22/2023	11:30-11:51	0.141	0.131	0.010	Y	186.4
3	3/22/2023	12:05-12:26	0.146	0.132	0.014	Y	191.3
4	3/22/2023	13:15-13:36	0.147	0.132	0.015	N	184.5
5	3/22/2023	13:55-14:16	0.145	0.141	0.004	Y	189.0
6	3/22/2023	14:35-14:56	0.154	0.140	0.014	Y	188.1
7	3/22/2023	15:30-15:51	0.156	0.144	0.012	Y	188.8
8	3/23/2023	7:30-7:51	0.152	0.139	0.013	Y	241.6
9	3/23/2023	8:05-8:26	0.155	0.159	-0.004	Y	241.0
10	3/23/2023	8:45-9:06	0.168	0.165	0.003	Y	241.6
11	3/23/2023	9:20-9:41	0.180	0.162	0.018	N	240.0
Averages			0.151	0.144	0.007		207.1
Standard Deviation			0.0079				
Confidence Coefficient (CC)			0.0061				
Unit Load			Normal				
RA based on mean RM value			8.37	%			

\* PEMS data provided by CMC Solutions, LLC.

**Table 4-11**  
**CO (ppmvd) RATA Results**  
**EUBOILER3**

Run No.	Date	Time	RM	PEMS*	Difference	Run used (Y/N)	Steam Load (klb/hr)
1	3/22/2023	10:10-10:31	-0.514	1.364	-1.878	N	195.8
2	3/22/2023	11:30-11:51	-0.691	0.631	-1.322	Y	186.4
3	3/22/2023	12:05-12:26	-0.542	1.076	-1.618	N	191.3
4	3/22/2023	13:15-13:36	-0.685	0.852	-1.537	Y	184.5
5	3/22/2023	13:55-14:16	-0.611	0.850	-1.461	Y	189.0
6	3/22/2023	14:35-14:56	-0.611	0.743	-1.354	Y	188.1
7	3/22/2023	15:30-15:51	-0.530	0.984	-1.514	Y	188.8
8	3/23/2023	7:30-7:51	-0.522	0.422	-0.944	Y	241.6
9	3/23/2023	8:05-8:26	-0.774	0.520	-1.294	Y	241.0
10	3/23/2023	8:45-9:06	-0.625	0.375	-1.000	Y	241.6
11	3/23/2023	9:20-9:41	-0.778	0.461	-1.239	Y	240.0
Averages			-0.647	0.649	-1.296		211.2
Unit Load			Normal				
RA based on   mean difference			1.30	ppmvd as CO			

\* PEMS data provided by CMC Solutions, LLC.

**Table 4-12**  
**O<sub>2</sub> (%-Dry) RATA Results**  
**EUBOILER3**

Run No.	Date	Time	RM	PEMS*	Difference	Run used (Y/N)	Steam Load (klb/hr)
1	3/22/2023	10:10-10:31	5.230	5.369	-0.139	Y	195.8
2	3/22/2023	11:30-11:51	5.386	5.488	-0.102	Y	186.4
3	3/22/2023	12:05-12:26	5.358	5.268	0.090	Y	191.3
4	3/22/2023	13:15-13:36	5.353	5.233	0.120	Y	184.5
5	3/22/2023	13:55-14:16	5.366	5.155	0.211	Y	189.0
6	3/22/2023	14:35-14:56	5.375	5.225	0.150	Y	188.1
7	3/22/2023	15:30-15:51	5.350	5.243	0.107	Y	188.8
8	3/23/2023	7:30-7:51	5.421	5.475	-0.054	Y	241.6
9	3/23/2023	8:05-8:26	5.317	5.835	-0.518	N	241.0
10	3/23/2023	8:45-9:06	5.394	5.716	-0.322	N	241.6
11	3/23/2023	9:20-9:41	5.505	5.691	-0.186	Y	240.0
Averages			5.372	5.350	0.022		200.6
Unit Load			Normal				
RA based on   mean difference			0.022	% as O <sub>2</sub>			

\* PEMS data provided by CMC Solutions, LLC.

**Table 4-13**  
**NO<sub>x</sub> (lb/MMBtu) RATA Results**  
**EUCTG1**

Run No.	Date	Time	RM	PEMS*	Difference	Run used (Y/N)	Turbine Load (MW)
1	3/20/2023	6:55-7:16	0.0275	0.0300	-0.0025	N	187.7
2	3/20/2023	7:25-7:46	0.0283	0.0300	-0.0017	Y	187.6
3	3/20/2023	8:20-8:41	0.0293	0.0300	-0.0007	Y	186.7
4	3/20/2023	8:50-9:11	0.0289	0.0300	-0.0011	Y	186.0
5	3/20/2023	9:20-9:41	0.0300	0.0300	0.0000	Y	185.4
6	3/20/2023	9:55-10:16	0.0282	0.0300	-0.0018	Y	184.7
7	3/20/2023	10:25-10:46	0.0293	0.0310	-0.0017	Y	184.4
8	3/20/2023	10:55-11:16	0.0296	0.0310	-0.0014	Y	183.4
9	3/20/2023	11:25-11:46	0.0290	0.0310	-0.0020	Y	182.2
10	3/20/2023	12:00-12:21	0.0294	0.0310	-0.0016	Y	180.7
Averages			0.0291	0.0304	-0.0013		184.6
Unit Load			Normal				
RA† based on   mean difference			0.0013	lb/MMBtu as NO <sub>x</sub>			

\* PEMS data provided by CMC Solutions, LLC.

† RA not applicable because emissions were <0.05 lb/MMBtu.

**Table 4-14**  
**NO<sub>x</sub> (ppmvd corrected to 15% O<sub>2</sub>) RATA Results**  
**EUCTG1**

Run No.	Date	Time	RM	PEMS*	Difference	Run used (Y/N)	Turbine Load (MW)
1	3/20/2023	6:55-7:16	7.458	8.207	-0.749	N	187.7
2	3/20/2023	7:25-7:46	7.673	8.228	-0.555	Y	187.6
3	3/20/2023	8:20-8:41	7.943	8.271	-0.328	Y	186.7
4	3/20/2023	8:50-9:11	7.849	8.212	-0.363	Y	186.0
5	3/20/2023	9:20-9:41	8.139	8.193	-0.054	Y	185.4
6	3/20/2023	9:55-10:16	7.658	8.257	-0.599	Y	184.7
7	3/20/2023	10:25-10:46	7.960	8.410	-0.450	Y	184.4
8	3/20/2023	10:55-11:16	8.026	8.386	-0.360	Y	183.4
9	3/20/2023	11:25-11:46	7.870	8.292	-0.422	Y	182.2
10	3/20/2023	12:00-12:21	7.987	8.357	-0.370	Y	180.7
Averages			7.901	8.290	-0.389		184.6
Unit Load			Normal				
RA based on   mean difference			0.39	ppmvd as NO <sub>x</sub>			

\* PEMS data provided by CMC Solutions, LLC.

**Table 4-15**  
**CO (ppmvd) RATA Results**  
**EUCTG1**

Run No.	Date	Time	RM	PEMS*	Difference	Run used (Y/N)	Turbine Load (MW)
1	3/20/2023	6:55-7:16	1.065	2.473	-1.408	Y	187.7
2	3/20/2023	7:25-7:46	1.095	2.650	-1.555	Y	187.6
3	3/20/2023	8:20-8:41	0.980	2.649	-1.669	N	186.7
4	3/20/2023	8:50-9:11	1.123	2.635	-1.512	Y	186.0
5	3/20/2023	9:20-9:41	1.086	2.624	-1.538	Y	185.4
6	3/20/2023	9:55-10:16	1.315	2.654	-1.339	Y	184.7
7	3/20/2023	10:25-10:46	1.169	2.757	-1.588	Y	184.4
8	3/20/2023	10:55-11:16	1.123	2.290	-1.167	Y	183.4
9	3/20/2023	11:25-11:46	1.146	2.303	-1.157	Y	182.2
10	3/20/2023	12:00-12:21	1.193	2.364	-1.171	Y	180.7
Averages			1.146	2.528	-1.382		184.7
Unit Load			Normal				
RA based on   mean difference			1.38	ppmvd as CO			

\* PEMS data provided by CMC Solutions, LLC.

**Table 4-16**  
**O<sub>2</sub> (%-Dry) RATA Results**  
**EUCTG1**

Run No.	Date	Time	RM	PEMS*	Difference	Run used (Y/N)	Turbine Load (MW)
1	3/20/2023	6:55-7:16	13.316	13.780	-0.464	N	187.7
2	3/20/2023	7:25-7:46	13.529	13.801	-0.272	Y	187.6
3	3/20/2023	8:20-8:41	13.602	13.808	-0.206	Y	186.7
4	3/20/2023	8:50-9:11	13.567	13.802	-0.235	Y	186.0
5	3/20/2023	9:20-9:41	13.519	13.800	-0.281	Y	185.4
6	3/20/2023	9:55-10:16	13.493	13.807	-0.314	Y	184.7
7	3/20/2023	10:25-10:46	13.400	13.822	-0.422	Y	184.4
8	3/20/2023	10:55-11:16	13.574	13.799	-0.225	Y	183.4
9	3/20/2023	11:25-11:46	13.449	13.805	-0.356	Y	182.2
10	3/20/2023	12:00-12:21	13.456	13.799	-0.343	Y	180.7
Averages			13.510	13.805	-0.295		184.6
Unit Load			Normal				
RA based on   mean difference			0.29	% as O <sub>2</sub>			

\* PEMS data provided by CMC Solutions, LLC.

**Table 4-17**  
**NO<sub>x</sub> (lb/MMBtu) RATA Results**  
**EUCTG2**

Run No.	Date	Time	RM	PEMS*	Difference	Run used (Y/N)	Turbine Load (MW)
1	3/20/2023	14:10-14:31	0.0267	0.0280	-0.0013	Y	184.5
2	3/20/2023	14:50-15:11	0.0270	0.0270	0.0000	Y	183.3
3	3/20/2023	15:20-15:41	0.0262	0.0270	-0.0008	Y	183.2
4	3/20/2023	15:55-16:16	0.0269	0.0270	-0.0001	Y	183.2
5	3/20/2023	16:30-16:51	0.0278	0.0270	0.0008	Y	183.7
6	3/20/2023	17:05-17:26	0.0274	0.0270	0.0004	Y	183.4
7	3/20/2023	17:40-18:01	0.0264	0.0270	-0.0006	Y	183.5
8	3/20/2023	18:15-18:36	0.0269	0.0270	-0.0001	Y	183.7
9	3/20/2023	18:50-19:11	0.0250	0.0270	-0.0020	Y	183.3
10	3/20/2023	19:35-19:56	0.0247	0.0270	-0.0023	N	183.4
Averages			0.0267	0.0271	-0.0004		183.5
Unit Load			Normal				
RA† based on   mean difference			0.0004	lb/MMBtu as NO <sub>x</sub>			

\* PEMS data provided by CMC Solutions, LLC.

† RA not applicable because emissions were <0.05 lb/MMBtu.



**Table 4-18**  
**NO<sub>x</sub> (ppmvd corrected to 15% O<sub>2</sub>) RATA Results**  
**EUCTG2**

Run No.	Date	Time	RM	PEMS*	Difference	Run used (Y/N)	Turbine Load (MW)
1	3/20/2023	14:10-14:31	7.252	7.482	-0.230	Y	184.5
2	3/20/2023	14:50-15:11	7.316	7.443	-0.127	Y	183.3
3	3/20/2023	15:20-15:41	7.099	7.437	-0.338	Y	183.2
4	3/20/2023	15:55-16:16	7.289	7.437	-0.148	Y	183.2
5	3/20/2023	16:30-16:51	7.534	7.460	0.074	Y	183.7
6	3/20/2023	17:05-17:26	7.449	7.445	0.004	Y	183.4
7	3/20/2023	17:40-18:01	7.164	7.452	-0.288	Y	183.5
8	3/20/2023	18:15-18:36	7.296	7.459	-0.163	Y	183.7
9	3/20/2023	18:50-19:11	6.793	7.440	-0.647	Y	183.3
10	3/20/2023	19:35-19:56	6.698	7.443	-0.745	N	183.4
Averages			7.243	7.451	-0.207		183.5
Unit Load			Normal				
RA based on   mean difference			0.21	ppmvd as NO <sub>x</sub>			

\* PEMS data provided by CMC Solutions, LLC.

**Table 4-19**  
**CO (ppmvd) RATA Results**  
**EUCTG2**

Run No.	Date	Time	RM	PEMS*	Difference	Run used (Y/N)	Turbine Load (MW)
1	3/20/2023	14:10-14:31	1.135	1.183	-0.048	Y	184.5
2	3/20/2023	14:50-15:11	1.056	1.198	-0.142	Y	183.3
3	3/20/2023	15:20-15:41	0.887	1.199	-0.312	Y	183.2
4	3/20/2023	15:55-16:16	0.970	1.200	-0.230	Y	183.2
5	3/20/2023	16:30-16:51	1.008	1.191	-0.183	Y	183.7
6	3/20/2023	17:05-17:26	1.261	1.197	0.064	Y	183.4
7	3/20/2023	17:40-18:01	0.551	1.195	-0.644	N	183.5
8	3/20/2023	18:15-18:36	0.587	1.192	-0.605	Y	183.7
9	3/20/2023	18:50-19:11	1.087	1.199	-0.112	Y	183.3
10	3/20/2023	19:35-19:56	0.913	1.197	-0.284	Y	183.4
Averages			0.989	1.195	-0.206		183.5
Unit Load			Normal				
RA based on   mean difference			0.21	ppmvd as CO			

\* PEMS data provided by CMC Solutions, LLC.

RECEIVED

JUN 01 2023

AIR QUALITY DIVISION

**Table 4-20**  
**O<sub>2</sub> (%-Dry) RATA Results**  
**EUCTG2**

Run No.	Date	Time	RM	PEMS*	Difference	Run used (Y/N)	Turbine Load (MW)
1	3/20/2023	14:10-14:31	13.167	13.110	0.057	Y	184.5
2	3/20/2023	14:50-15:11	13.187	13.090	0.097	Y	183.3
3	3/20/2023	15:20-15:41	13.191	13.090	0.101	Y	183.2
4	3/20/2023	15:55-16:16	13.158	13.084	0.074	Y	183.2
5	3/20/2023	16:30-16:51	13.193	13.094	0.099	Y	183.7
6	3/20/2023	17:05-17:26	13.171	13.087	0.084	Y	183.4
7	3/20/2023	17:40-18:01	13.170	13.091	0.079	Y	183.5
8	3/20/2023	18:15-18:36	13.175	13.093	0.082	Y	183.7
9	3/20/2023	18:50-19:11	13.210	13.086	0.124	Y	183.3
10	3/20/2023	19:35-19:56	13.229	13.086	0.143	N	183.4
Averages			13.180	13.092	0.088		183.5
Unit Load			Normal				
RA based on   mean difference			0.088	% as O <sub>2</sub>			

\* PEMS data provided by CMC Solutions, LLC.

**Table 4-21**  
**NO<sub>x</sub> (lb/MMBtu) RATA Results**  
**EUCTG3**

Run No.	Date	Time	RM	PEMS*	Difference	Run used (Y/N)	Turbine Load (MW)
1	3/20/2023	7:55-8:16	0.0205	0.0210	-0.0005	Y	190.2
2	3/20/2023	8:25-8:46	0.0207	0.0210	-0.0003	Y	189.6
3	3/20/2023	9:00-9:21	0.0209	0.0210	-0.0001	Y	188.7
4	3/20/2023	9:35-9:56	0.0204	0.0210	-0.0006	Y	187.7
5	3/20/2023	10:20-10:41	0.0196	0.0210	-0.0014	N	185.9
6	3/20/2023	10:55-11:16	0.0206	0.0210	-0.0004	Y	185.4
7	3/20/2023	11:40-12:01	0.0216	0.0210	0.0006	Y	184.4
8	3/20/2023	12:15-12:36	0.0209	0.0210	-0.0001	Y	184.4
9	3/20/2023	12:40-13:01	0.0205	0.0210	-0.0005	Y	183.2
10	3/20/2023	13:15-13:36	0.0210	0.0210	0.0000	Y	184.0
Averages			0.0208	0.0210	-0.0002		186.4
Unit Load			Normal				
RA based† on   mean difference			0.0002	lb/MMBtu as NO <sub>x</sub>			

\* PEMS data provided by CMC Solutions, LLC.

† RA not applicable because emissions were <0.05 lb/MMBtu.

**Table 4-22**  
**NO<sub>x</sub> (ppmvd corrected to 15% O<sub>2</sub>) RATA Results**  
**EUCTG3**

Run No.	Date	Time	RM	PEMS*	Difference	Run used (Y/N)	Turbine Load (MW)
1	3/20/2023	7:55-8:16	5.561	5.792	-0.231	Y	190.2
2	3/20/2023	8:25-8:46	5.623	5.772	-0.149	Y	189.6
3	3/20/2023	9:00-9:21	5.669	5.752	-0.083	Y	188.7
4	3/20/2023	9:35-9:56	5.540	5.712	-0.172	Y	187.7
5	3/20/2023	10:20-10:41	5.310	5.668	-0.358	N	185.9
6	3/20/2023	10:55-11:16	5.590	5.686	-0.096	Y	185.4
7	3/20/2023	11:40-12:01	5.867	5.772	0.095	Y	184.4
8	3/20/2023	12:15-12:36	5.672	5.776	-0.104	Y	184.4
9	3/20/2023	12:40-13:01	5.556	5.800	-0.244	Y	183.2
10	3/20/2023	13:15-13:36	5.691	5.795	-0.104	Y	184.0
Averages			5.641	5.762	-0.121		186.4
Unit Load			Normal				
RA based on   mean difference			0.12	ppmvd as NO <sub>x</sub>			

\* PEMS data provided by CMC Solutions, LLC.

**Table 4-23**  
**CO (ppmvd) RATA Results**  
**EUCTG3**

Run No.	Date	Time	RM	PEMS*	Difference	Run used (Y/N)	Turbine Load (MW)
1	3/20/2023	7:55-8:16	0.818	1.615	-0.797	Y	190.2
2	3/20/2023	8:25-8:46	0.959	1.613	-0.654	Y	189.6
3	3/20/2023	9:00-9:21	0.876	1.631	-0.755	Y	188.7
4	3/20/2023	9:35-9:56	0.793	1.703	-0.910	Y	187.7
5	3/20/2023	10:20-10:41	0.909	1.729	-0.820	Y	185.9
6	3/20/2023	10:55-11:16	0.836	1.731	-0.895	Y	185.4
7	3/20/2023	11:40-12:01	0.612	1.752	-1.140	N	184.4
8	3/20/2023	12:15-12:36	0.711	1.751	-1.040	Y	184.4
9	3/20/2023	12:40-13:01	0.993	1.787	-0.794	Y	183.2
10	3/20/2023	13:15-13:36	0.937	1.764	-0.827	Y	184.0
Averages			0.870	1.703	-0.832		186.6
Unit Load			Normal				
RA based on   mean difference			0.83	ppmvd as CO			

\* PEMS data provided by CMC Solutions, LLC.

**Table 4-24**  
**O<sub>2</sub> (%-Dry) RATA Results**  
**EUCTG3**

Run No.	Date	Time	RM	PEMS*	Difference	Run used (Y/N)	Turbine Load (MW)
1	3/20/2023	7:55-8:16	13.128	12.914	0.214	Y	190.2
2	3/20/2023	8:25-8:46	13.124	12.902	0.222	Y	189.6
3	3/20/2023	9:00-9:21	13.130	12.884	0.246	Y	188.7
4	3/20/2023	9:35-9:56	13.142	12.867	0.275	N	187.7
5	3/20/2023	10:20-10:41	13.147	12.912	0.235	Y	185.9
6	3/20/2023	10:55-11:16	13.135	12.963	0.172	Y	185.4
7	3/20/2023	11:40-12:01	13.178	13.172	0.006	Y	184.4
8	3/20/2023	12:15-12:36	13.177	13.176	0.001	Y	184.4
9	3/20/2023	12:40-13:01	13.181	13.291	-0.110	Y	183.2
10	3/20/2023	13:15-13:36	13.171	13.233	-0.062	Y	184.0
Averages			13.152	13.050	0.103		186.2
Unit Load			Normal				
RA based on   mean difference			0.10	% as O <sub>2</sub>			

\* PEMS data provided by CMC Solutions, LLC.

## 5.0 Internal QA/QC Activities

### 5.1 QA/QC Audits

Table 5-1 presents a summary of the gas cylinder information.

**Table 5-1**  
**Part 60 Gas Cylinder Information**

Gas Type	Gas Concentrations	Cylinder ID	Expiration Date
O <sub>2</sub> , Balance N <sub>2</sub>	9.969%	CC210720	9/2/2030
O <sub>2</sub> , Balance N <sub>2</sub>	10.08%	ALM-041308	11/10/2030
O <sub>2</sub> , Balance N <sub>2</sub>	19.91%	SG9162511BAL	9/2/2030
SO <sub>2</sub> , Balance N <sub>2</sub>	49.54 ppmv	CC429472	8/26/2030
SO <sub>2</sub> , Balance N <sub>2</sub>	90.78 ppmv	AAL069508	11/30/2029
NO <sub>x</sub> , Balance N <sub>2</sub>	50.06 ppmv	CC429472	8/26/2030
NO <sub>x</sub> , Balance N <sub>2</sub>	91.39 ppmv	AAL069508	11/30/2029
NO <sub>2</sub> , Balance Air	50.32 ppmv	EB0147946	9/14/2025
CO, Balance N <sub>2</sub>	49.88 ppmv	CC429472	8/26/2030
CO, Balance N <sub>2</sub>	90.41 ppmv	AAL069508	11/30/2029

EPA Method 3A, 6C, 7E, and 10 calibration audits were all within the measurement system performance specifications for the calibration drift checks, system calibration bias checks, and calibration error checks.

The NO<sub>2</sub> to NO converter efficiency check of the analyzer was conducted per the procedures in EPA Method 7E, Section 8.2.4. The conversion efficiency met the criteria.

### 5.2 QA/QC Discussion

All QA/QC criteria were met during this test program.





### 5.3 Quality Statement

Montrose is qualified to conduct this test program and has established a quality management system that led to accreditation with ASTM Standard D7036-04 (Standard Practice for Competence of Air Emission Testing Bodies). Montrose participates in annual functional assessments for conformance with D7036-04 which are conducted by the American Association for Laboratory Accreditation (A2LA). All testing performed by Montrose is supervised on site by at least one Qualified Individual (QI) as defined in D7036-04 Section 8.3.2. Data quality objectives for estimating measurement uncertainty within the documented limits in the test methods are met by using approved test protocols for each project as defined in D7036-04 Sections 7.2.1 and 12.10. Additional quality assurance information is included in the report appendices. The content of this report is modeled after the EPA Emission Measurement Center Guideline Document (GD-043).

## **Appendix A**

### **Field Data and Calculations**

**RECEIVED**

**JUN 01 2023**

**AIR QUALITY DIVISION**

## **Appendix A.1**

### **Sampling Locations**

### BOILERS SAMPLING LOCATION SCHEMATIC

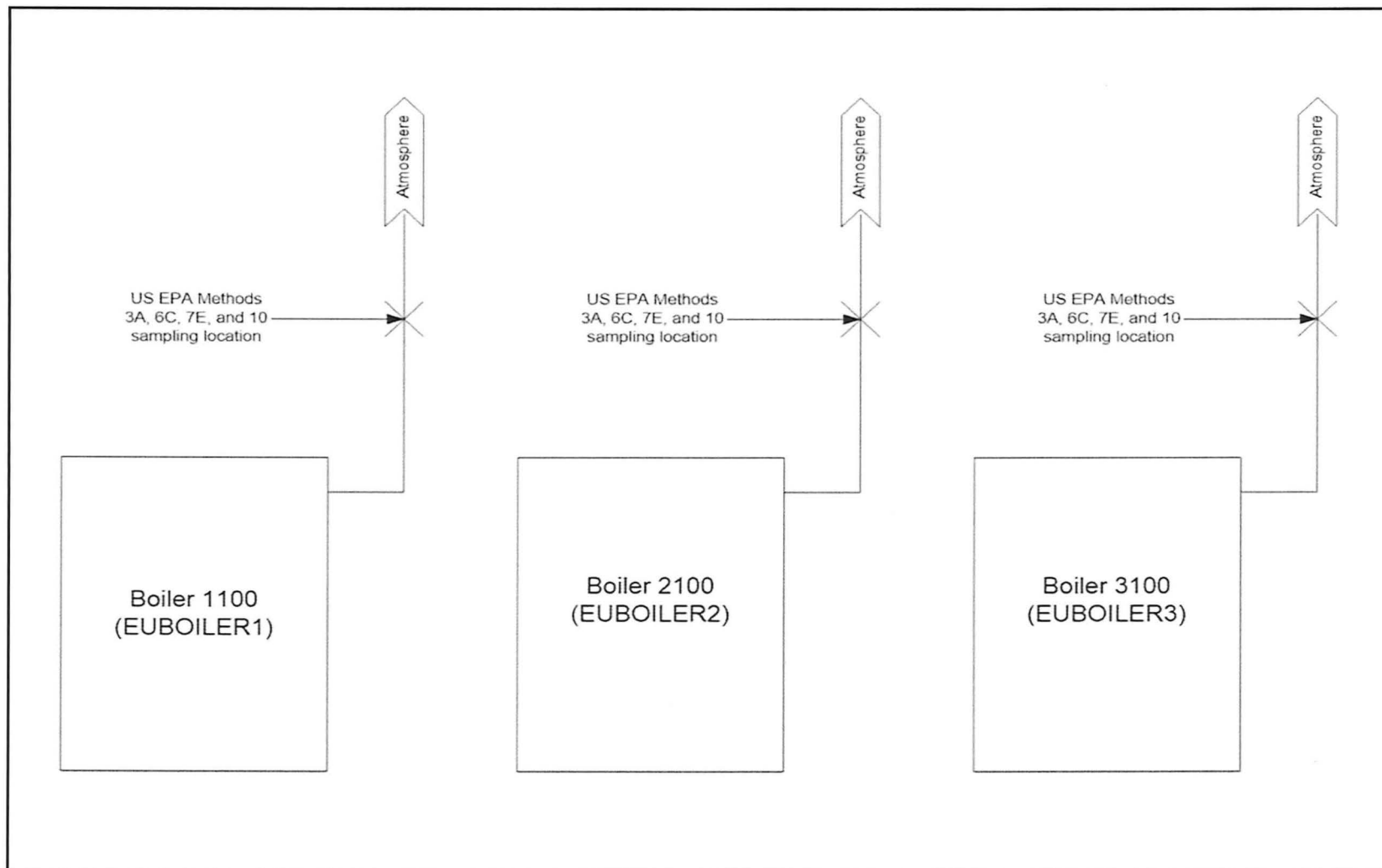

**EUBOILER1 EXHAUST TRAVERSE POINT LOCATION DRAWING**

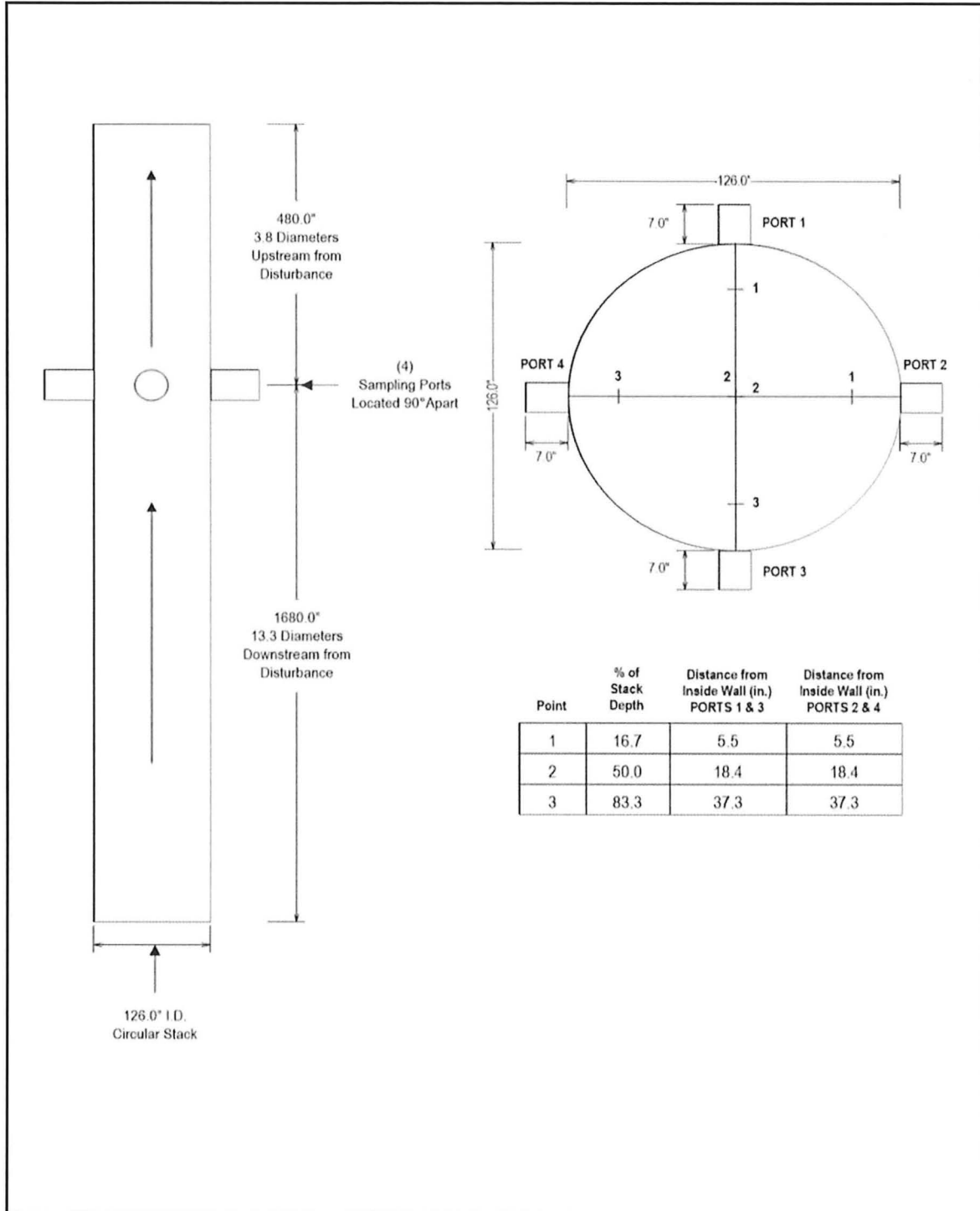

**EUBOILER2 EXHAUST TRAVERSE POINT LOCATION DRAWING**

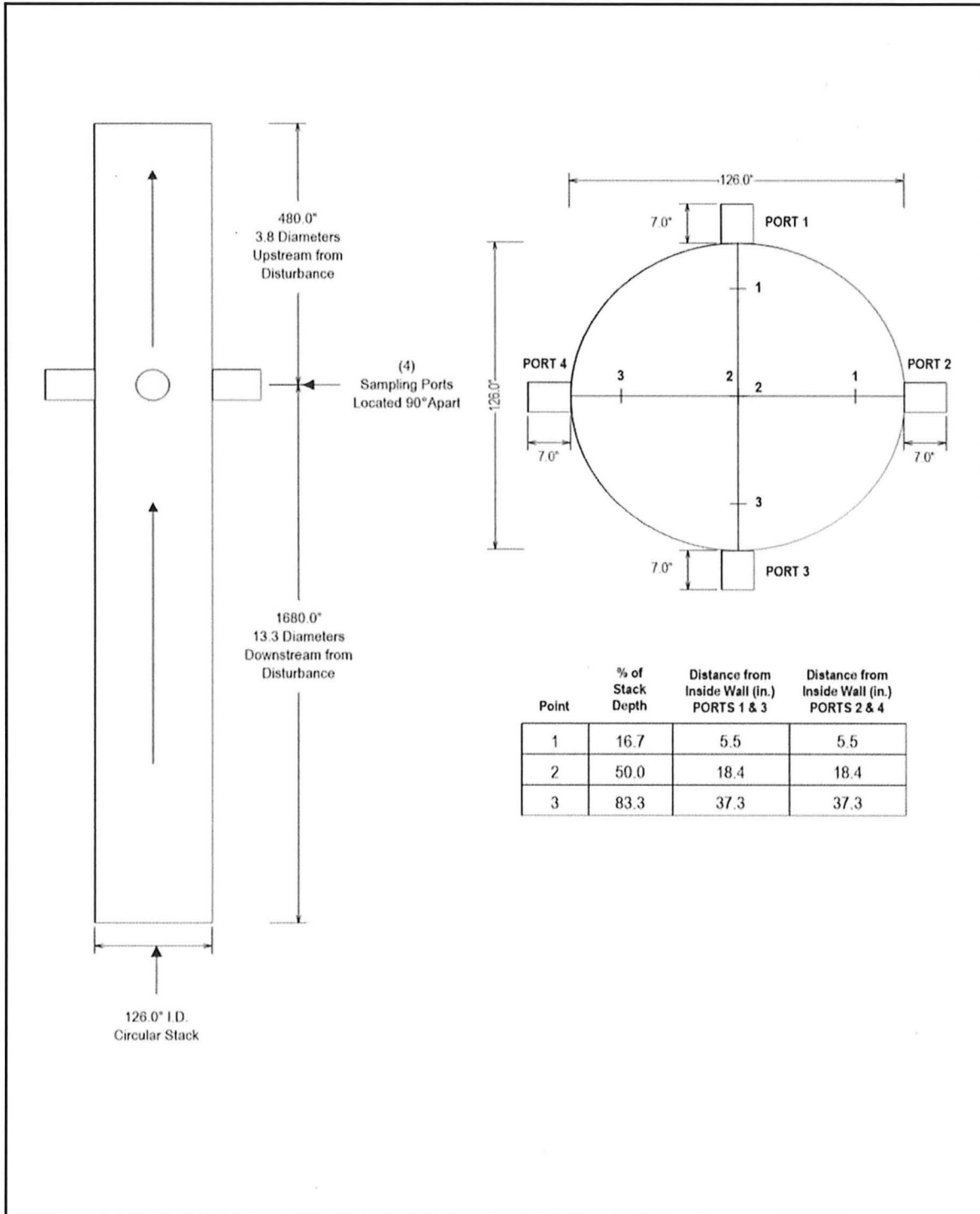

**EUBOILER3 EXHAUST TRAVERSE POINT LOCATION DRAWING**

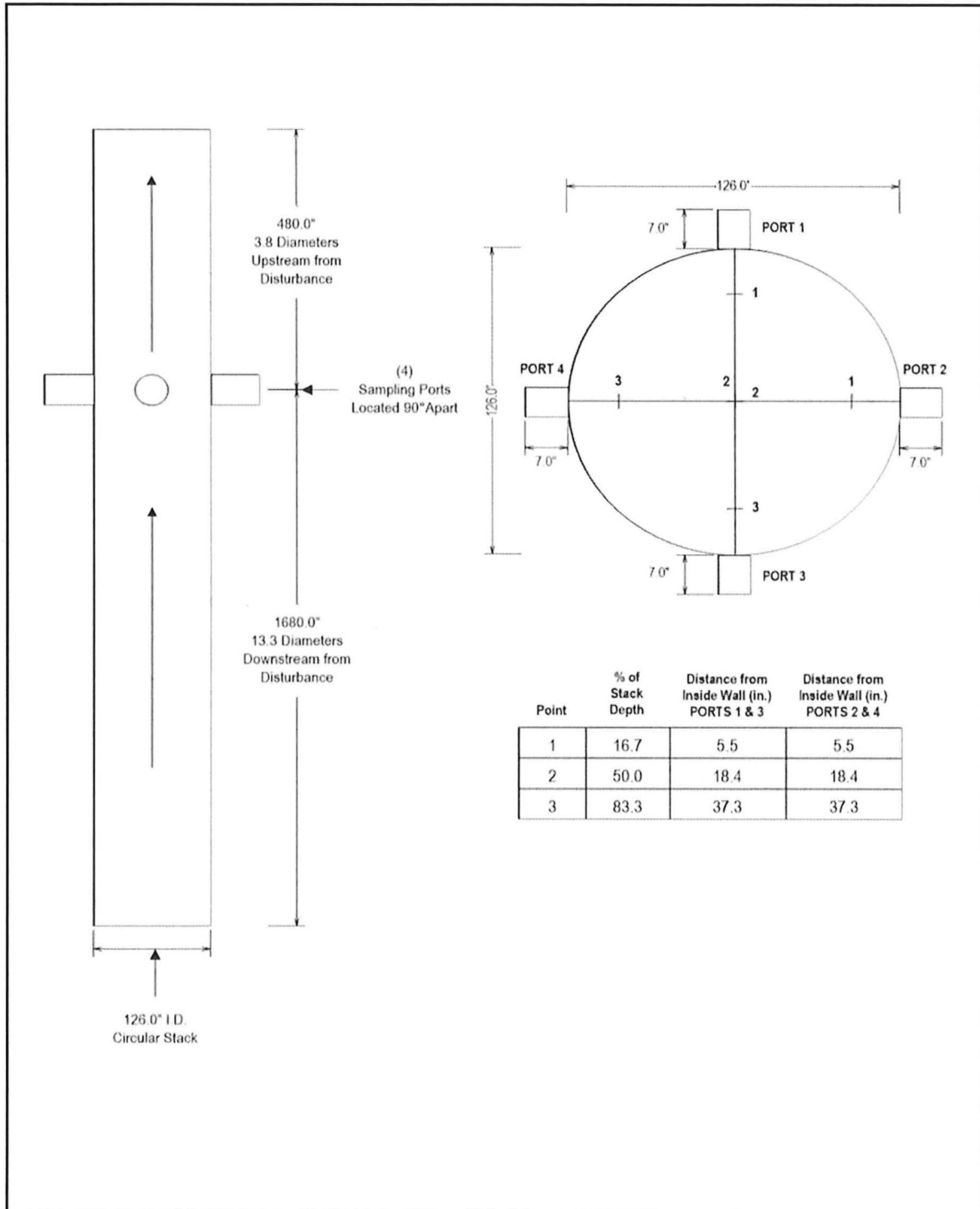

### TURBINES SAMPLING LOCATION SCHEMATIC

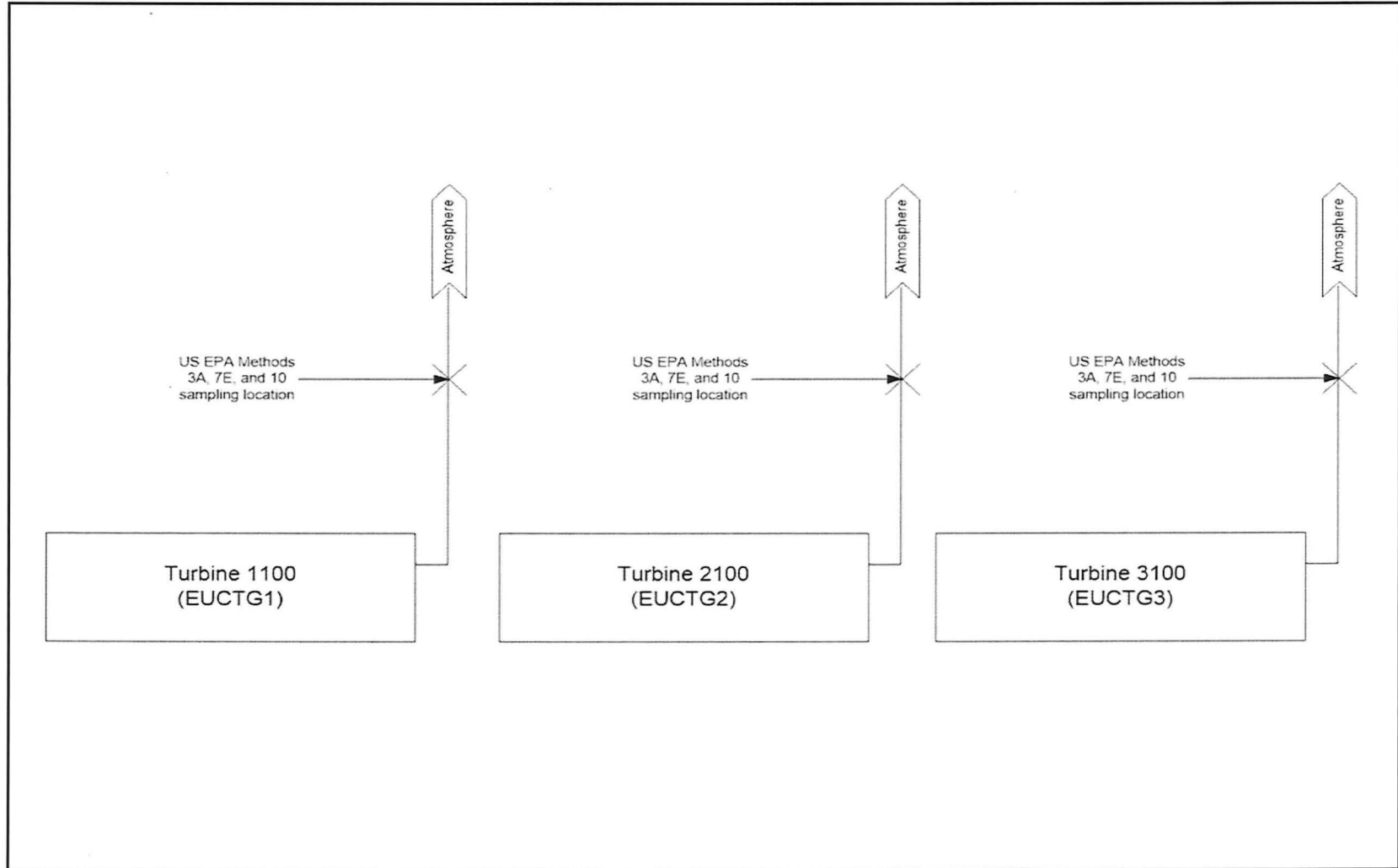



**EUCTG1 EXHAUST TRAVERSE POINT LOCATION DRAWING**

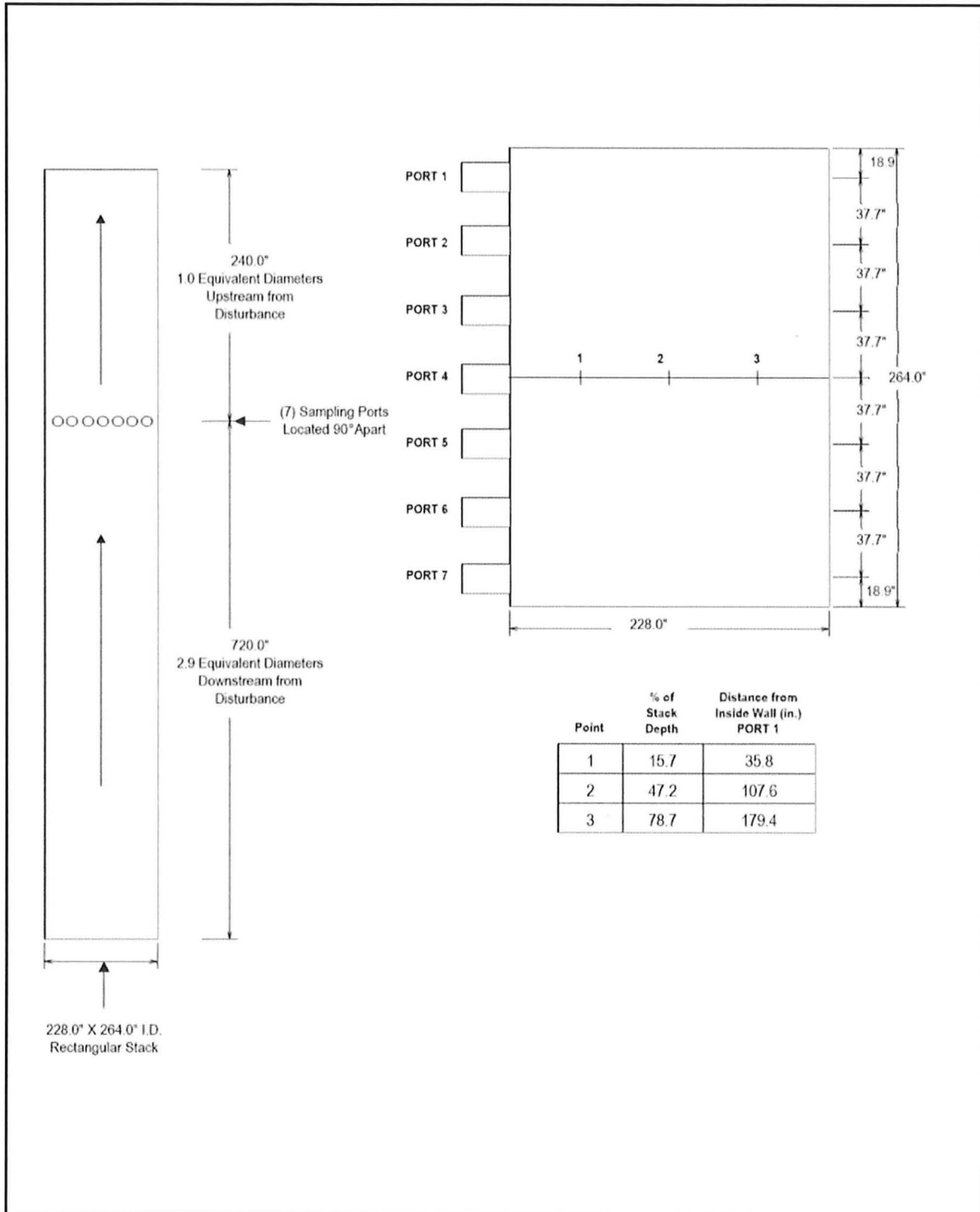

**EUCTG2 EXHAUST TRAVERSE POINT LOCATION DRAWING**

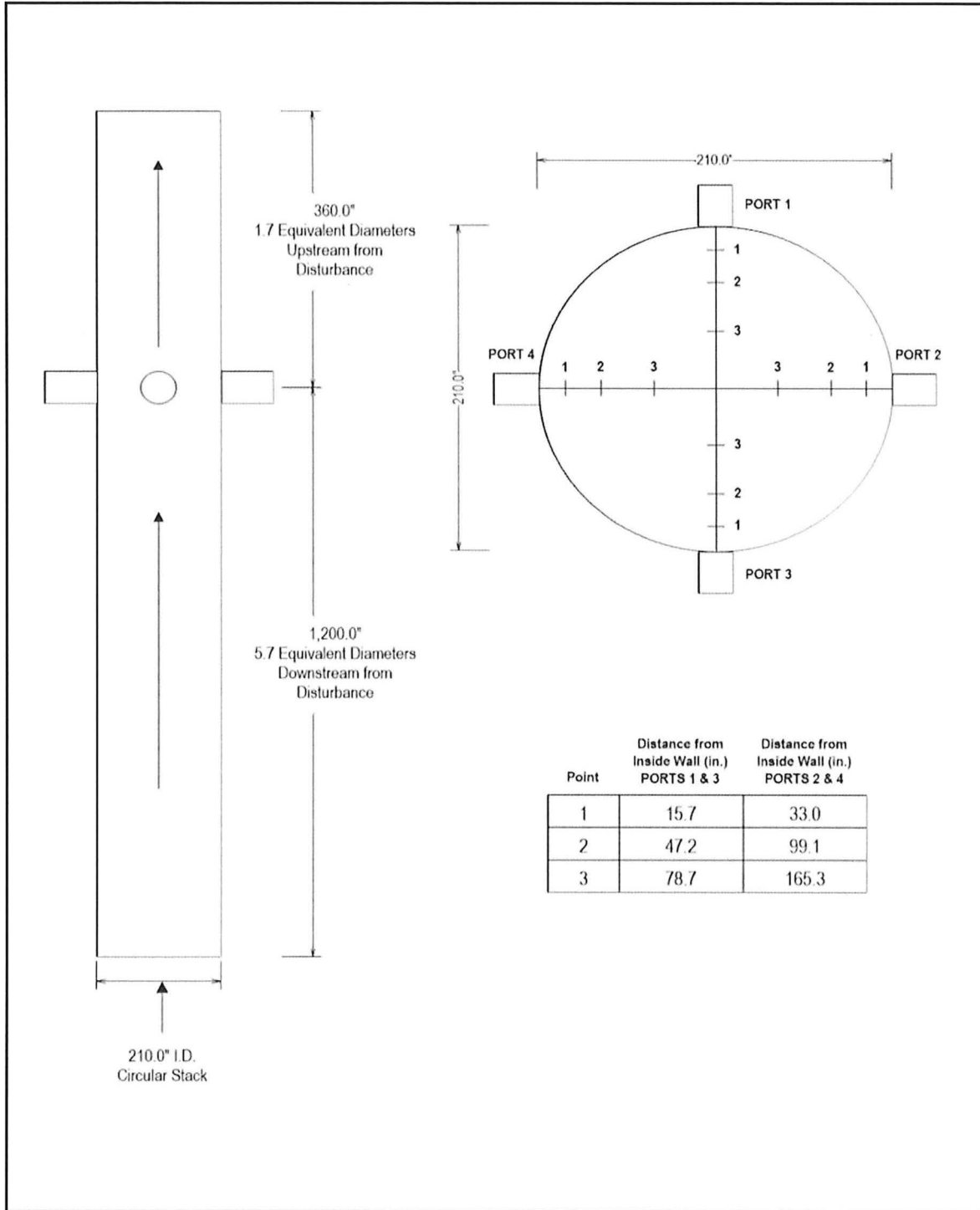

**EUCTG3 EXHAUST TRAVERSE POINT LOCATION DRAWING**

