

**SOURCE TEST REPORT  
2019 CONTROL EFFICIENCY  
BLUEWATER GAS STORAGE, LLC  
BLUEWATER GAS STORAGE STATION  
OXIDIZER C195  
COLUMBUS, MICHIGAN**

Prepared For:

**Bluewater Gas Storage**

333 S. Wales Center  
Columbus, MI 48063

Prepared By:

**Montrose Air Quality Services, LLC**

1371 Brummel Avenue  
Elk Grove Village, IL 60007

Document Number:	<b>023AS-659715-RT-335</b>
Test Date:	<b>December 17, 2019</b>
Document Date:	<b>January 22, 2020</b>





### REVIEW AND CERTIFICATION

All work, calculations, and other activities and tasks performed and presented in this document were carried out by me or under my direction and supervision. I hereby certify that, to the best of my knowledge, Montrose operated in conformance with the requirements of the Montrose Quality Management System and ASTM D7036-04 during this test project.

Signature: Brandon Check Date: 01/22/2020

Name: Brandon Check Title: Client Project Manager

I have reviewed, technically and editorially, details calculations, results, conclusions, and other appropriate written materials contained herein. I hereby certify that, to the best of my knowledge, the presented material is authentic, accurate, and conforms to the requirements of the Montrose Quality Management System and ASTM D7036-04.

Signature: Roy Slick Date: 01/22/2020

Name: Roy Slick Title: Reporting/QC Specialist



## TABLE OF CONTENTS

<b><u>SECTION</u></b>	<b><u>PAGE</u></b>
1.0 PROJECT OVERVIEW.....	4
1.1 GENERAL.....	4
1.2 METHODOLOGY.....	4
1.2.1 Control Efficiency Methodology.....	4
1.3 RESULTS.....	4
1.4 QUALITY STATEMENT.....	5
2.0 SUMMARY OF RESULTS.....	6
3.0 TEST PROCEDURES.....	7
3.1 Method Listing.....	7
3.2 METHOD DESCRIPTIONS.....	7
3.2.1 Method 1.....	7
3.2.2 Method 2.....	7
3.2.3 Method 3.....	8
3.2.4 Method 4.....	8
3.2.5 Method 25A.....	9
4.0 DESCRIPTION OF INSTALLATION.....	10

### LIST OF TABLES

TABLE 2-1 OXIDIZER C195 CONTROL EFFICIENCY TEST RESULTS.....	6
--	---

### LIST OF APPENDICES

APPENDIX A FIGURES

APPENDIX B SAMPLE CALCULATIONS

APPENDIX C PARAMETERS

APPENDIX D FIELD DATA PRINTOUTS

APPENDIX E FIELD DATA

APPENDIX F ANALYZER DATA

APPENDIX G CALIBRATION DATA

APPENDIX H PROCESS DATA



## **1.0 PROJECT OVERVIEW**

### **1.1 GENERAL**

Montrose Air Quality Services, LLC (Montrose) located at 1371 Brummel Avenue, Elk Grove Village, Illinois was contracted by Bluewater Gas Storage, LLC to perform an air emissions test program at their Bluewater Gas Storage Station located Columbus, Michigan. The objectives of the test program are as follows:

- Determine the control efficiency (CE) of one oxidizer designated C195.

Testing was performed to satisfy the requirements of the Michigan Department of Environmental - Quality (MDEQ) PTI, the United States Environmental Protection Agency (U.S. EPA), 40 CFR 63.6640 (c), Subpart ZZZZ, as applicable.

Testing was performed on December 17, 2019. Coordinating the field aspects of the test program were:

Shelly Heston – WEC Energy Group - (920) 433-1294

Frank Rasmussen – Bluewater Gas Storage - (810) 305-3912

Brandon Check – Montrose Air Quality Services

Observing on behalf of the Michigan Department of Environmental Quality were:

Lindsey Wells – Michigan Department of Environmental Quality

### **1.2 METHODOLOGY**

#### **1.2.1 Control Efficiency Methodology**

The control efficiency of the oxidizer was determined by performing EPA Method 25A for the determination of total hydrocarbons (THC) at the oxidizer inlet and outlet. Sampling at the inlet and outlet of the oxidizer was performed simultaneously.

### **1.3 RESULTS**

Results of the control efficiency testing can be found in Table 2-1. The average control efficiency for the three test runs was 99.99 percent.

The oxidizer bed temperature setting was 1400°F during the test program.

The total hydrocarbon (THC) values were recorded on a “wet” basis, the volumetric flow rates, expressed in terms of standard cubic feet per minute (scfm) were used to calculate the THC emission rates in terms of pounds per hour (lb/hr).

The high moisture and THC concentration at the inlet location made it difficult to perform a moisture determination and flow traverse. A pitot was mounted at the centroid of the duct so that the velocity could be measured from a safe location. The moisture was determined using





the moisture saturation point. The molecular weight of the inlet gas stream was determined using a weighted average of THC and nitrogen. THC was assumed to be propane and assigned a molecular weight of 44.10. The remaining components of the gas stream were assumed to be negligible for the purpose of calculating a molecular weight.

#### **1.4 QUALITY STATEMENT**

Montrose is qualified to conduct this test program and has established a quality management system that led to accreditation with ASTM Standard D7036-04 (Standard Practice for Competence of Air Emission Testing Bodies). Montrose participates in annual functional assessments for conformance with D7036-04 which are conducted by the American Association for Laboratory Accreditation (A2LA). All testing performed by Montrose is supervised on site by at least one Qualified Individual (QI) as defined in D7036-04 Section 8.3.2. Data quality objectives for estimating measurement uncertainty within the documented limits in the test methods are met by using approved test protocols for each project as defined in D7036-04 Sections 7.2.1 and 12.10. Additional quality assurance information is presented in the report appendices.



## 2.0 SUMMARY OF RESULTS

**TABLE 2-1  
 OXIDIZER C195 CONTROL EFFICIENCY TEST RESULTS**

Test Parameters	Run 1	Run 2	Run 3	Average
Date	12/17/2019	12/17/2019	12/17/2019	
Start Time	14:20	16:15	17:24	
Stop Time	15:20	17:15	18:24	
<b>Inlet Gas Conditions</b>				
Temperature (°F)	195	199	204	<b>199</b>
Volumetric Flow Rate (acfm)	124	152	176	<b>151</b>
Volumetric Flow Rate (scfm)	98.3	120	138	<b>100</b>
Volumetric Flow Rate (dscfm)	28.1	26.2	18.4	<b>20.0</b>
Moisture (%)	71.4	78.2	86.6	<b>78.7</b>
<b>Inlet Emissions</b>				
THC Concentration, as propane (ppmwv)	94,727	84,694	92,147	<b>90,523</b>
THC Emission Rate, as propane (lb/hr)	63.3	69.1	86.7	<b>73.0</b>
<b>Outlet Gas Conditions</b>				
Temperature (°F)	1218	1198	1203	<b>1206</b>
Volumetric Flow Rate (acfm)	4,600	4,700	4,700	<b>4,700</b>
Volumetric Flow Rate (scfm)	1,400	1,500	1,400	<b>1,400</b>
Volumetric Flow Rate (dscfm)	1,300	1,300	1,300	<b>1,300</b>
Carbon Dioxide (% dry)	0.8	0.8	0.8	<b>0.8</b>
Oxygen (% dry)	20.2	20.2	20.2	<b>20.2</b>
Moisture (%)	6.75	7.67	7.60	<b>7.34</b>
<b>Outlet Emissions</b>				
THC Concentration, as propane (ppmwv)	1.42	0.363	0.0346	<b>0.607</b>
THC Emission Rate, as propane (lb/hr)	0.0138	0.00364	0.000344	<b>0.00594</b>
THC CONTROL EFFICIENCY (%)	99.98	99.99	100.00	<b>99.99</b>

**Process Data**

Run	Dry Gas Flow MMSCF/D	Glycol Flow Rate GPM	Oxidizer Temp
1	184.7	3.9	1402
2	197.9	3.9	1403
3	198.5	3.9	1403



### 3.0 TEST PROCEDURES

#### 3.1 Method Listing

The test methods found in 40 CFR Part 60, Appendix A was referenced during the test program. The following individual methods were used:

- |            |  |
|------------|--|
| Method 1   | Sample and velocity traverses for stationary sources                                   |
| Method 2   | Determination of stack gas velocity and volumetric flow rate (Type-S pitot tube)       |
| Method 3   | Gas analysis for the determination of dry molecular weight                             |
| Method 4   | Determination of moisture content in stack gases                                       |
| Method 25A | Determination of total gaseous organic concentration using a flame ionization analyzer |

#### 3.2 METHOD DESCRIPTIONS

##### 3.2.1 Method 1

Method 1 was used to determine the suitability of the test locations and to determine the traverse points used for the volumetric flow rate determinations. Each test location conformed to the minimum requirements of being located at least two diameters downstream and at least 0.5 diameters upstream from the nearest flow disturbances.

The C195 Inlet test location was a horizontal, circular duct with a diameter of 3.5 inches. The test ports were located approximately 29.71 diameters downstream and 29.71 diameters upstream from the nearest flow disturbances. One point in the centroid of the duct was measured for the velocity determination over the duration of each run. A cross section of the inlet showing the sample points is shown in Figure 1 of the Appendix.

The C195 Outlet test location was a vertical, circular duct with a diameter of 15.0 inches. The test ports were located approximately 4.8 diameters downstream and 19.5 diameters upstream from the nearest flow disturbances. Eight points in each of the two test ports were traversed for the velocity determination. A cross section of the outlet showing the sample points is shown in Figure 2 of the Appendix.

##### 3.2.2 Method 2

EPA Method 2 was used to determine the gas velocity at each test location using “S” type pitot tubes and incline manometers. The manometers were leveled and “zeroed” prior to each test run. The sample trains were leak checked before and after each run by pressurizing the positive or “high” side, of each pitot tube and creating a 3 in.H<sub>2</sub>O deflection on the manometer. The leak check was considered valid if the manometer remained stable for 15 seconds. This procedure was repeated on the negative side by generating a vacuum of at least 3 in.H<sub>2</sub>O. The velocity head pressure and gas temperature were then determined at each point specified in Method 1. The static pressure of the duct was measured using water filled U-tube manometer. In addition, the barometric pressure was measured and recorded. A diagram of the Method 2 apparatus is shown in Figure 3 of the Appendix.



### 3.2.3 Method 3

The carbon dioxide and oxygen content was determined at the outlet test location using EPA Method 3. A gas sample was collected into a Tedlar bag from the back of the EPA Method 4 sample train for the duration of each test run. Analysis was performed using an Orsat gas analyzer.

The analyzer was leak checked prior to analysis by raising the liquid levels in each pipette to a reference mark on the capillary tubes and then closing the pipette valves. The burette solution was raised to bring the meniscus onto the graduated portion of the burette and the manifold valve was closed. The leak check was considered valid if after four minutes, the pipette meniscus did not fall below the reference mark and the burette meniscus did not fall by more than 0.2%.

The carbon dioxide content and oxygen content were used to calculate the dry molecular weight of the gas stream. The molecular weight was then used, along with the moisture content determined by EPA Method 4, for the calculation of the volumetric flow rate. For these calculations, the balance of the gas stream was assumed to be nitrogen since the other gas stream components are insignificant for the purposes of calculating molecular weight.

### 3.2.4 Method 4

The moisture content of the sample gas at each test location was determined using Method 4. A known volume of sample gas was withdrawn from the source and the moisture was condensed and measured. The dry standard volume of the sample gas was compared to the volume of moisture collected to determine the moisture content of the sample gas. The moisture content was then used, along with the measurements made in Methods 2 and 3, to calculate the volumetric flow rate through each test location. A diagram of the Method 4 sampling train is shown in Figure 4 of the Appendix.

To condense the water vapor, the gas sample was passed through a series of four impingers. The first two impingers each contained 100 ml of water. The third impinger was empty and the fourth contained a known weight of silica gel to absorb any remaining water vapor. The sample train was leak checked prior to the test run by capping the probe tip and pulling a vacuum greater than the highest vacuum expected during the test run. A leak check was considered valid if the leak rate was less than 0.02 cubic feet per minute.

The volume of dry gas exiting the gas condenser system was measured with a dry gas meter. After leaving the dry gas meter, the sample stream passed through an orifice used to meter the flow rate through the sample train. The pressure drop across the orifice was measured with an incline plane, oil manometer. The gas meter reading, gas meter inlet and outlet temperatures, gas meter static pressure and pump vacuum were recorded every five minutes during each test run. Each test run was 60 minutes in duration.

After the test run, the sample train was leak checked at the highest vacuum encountered during the test run. The amount of water collected in the condenser system was measured volumetrically with a graduated cylinder and the silica gel weight gain was determined gravimetrically. The net weight gain of water was converted to a volume of wet gas and compared to the amount of dry gas sampled to determine the moisture content.





### 3.2.5 Method 25A

The total hydrocarbon concentration at each location was determined using Method 25A. A sample of the gas stream was continuously withdrawn from the test location and analyzed using a continuous gas analysis system. A diagram of the Method 25A apparatus is shown in Figure 5 of the Appendix.

The sample gas was withdrawn from each location at a constant rate through a stainless steel probe and a Teflon sample line. The sample line was operated at a temperature of 250 °F to prevent the condensation of moisture. The sample gas was vented to a J.U.M. Engineering Model 3-500 gas analyzer. This analyzer used a flame ionization detector for the determination of total hydrocarbons. Results from this analyzer were determined on a “wet” basis. Hydrogen was used to fuel the instrument. The flame ionization analyzer (FIA) was calibrated with zero nitrogen and three known concentrations of propane in a balance of air. Each calibration gas was certified according to EPA Protocol 1 procedures.

Prior to sampling, a calibration error test was performed for the FIA. The zero and high-range calibration gases were introduced into the sampling system prior to the filter. The gas was drawn through the entire sampling system and the FIA was adjusted to the appropriate values. The mid and low-range gases were then introduced to the FIA and the measured values were recorded. The measured values for each calibration gas were then compared to the calibration gas values and the differences were less than the method requirement of five percent of the actual value.

After each test run the instrument drift for each FIA was determined by introducing the zero and mid-range calibration gases into the sampling system. The gas was drawn through the entire sampling system. The measured responses were then compared to the values from the previous test run to determine the analyzer drift. For all test runs, the analyzer drift was less than the method requirement of three percent of the span value.



#### 4.0 DESCRIPTION OF INSTALLATION

Dehydration Unit #8 has a 2.66 MMBTU/hr reboiler and a 9.8 MMBTU/hr oxidizer. The unit has a max glycol recirculation rate of 8 gal/min and has a dry gas flow of up to 465 MMSCF/day.

During dehydration, the natural gas passes through triethylene glycol (TEG) in the absorption tray contactors. The resultant moisture-laden TEG is then heated in a “glycol reboiler” to boil off the captured moisture and thus allow for reuse of the TEG. The process emission vent emits aliphatic and aromatic VOM, which result from the removal of certain naturally-occurring components of natural gas during dehydration. The VOM is controlled by the thermal oxidizer.



## **APPENDIX A FIGURES**

↑  
Up

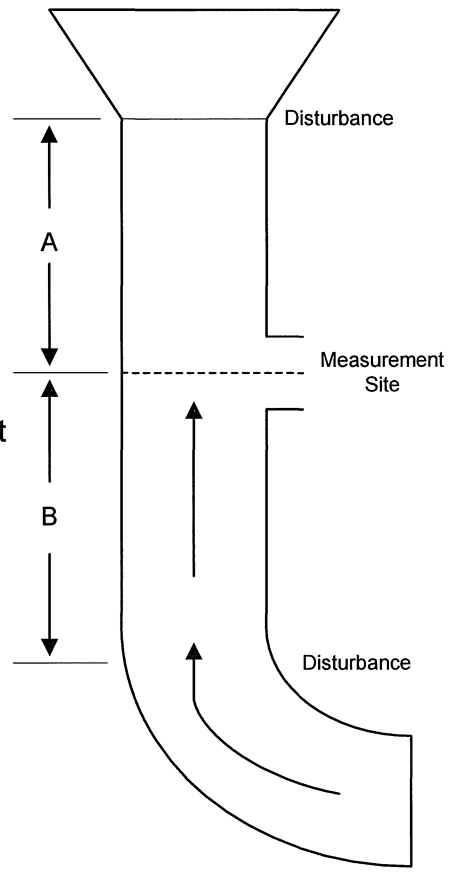
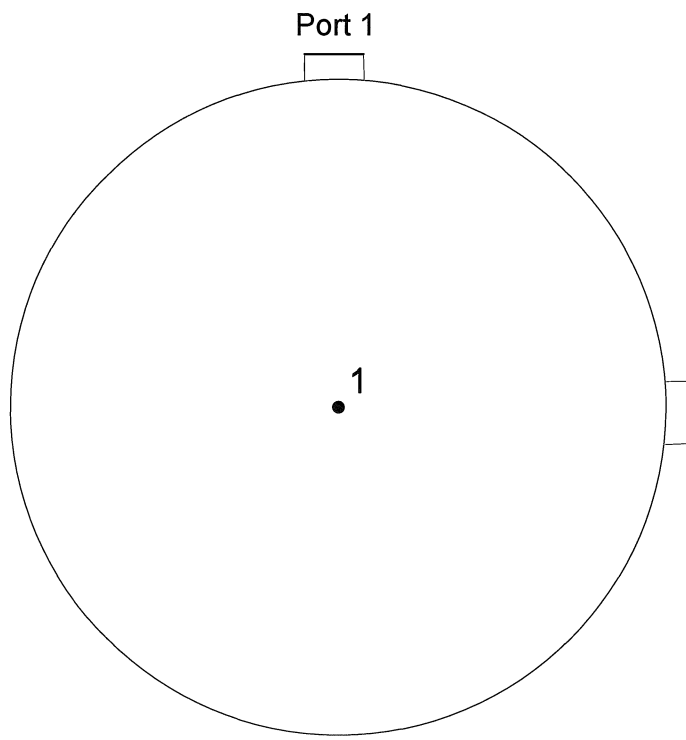

Diameter (in.)	3.5
Port Length (in.)	11.25
Distance A (Duct Diameters)	29.7
Distance B (Duct Diameters)	29.7

<u>Point</u>	<u>Distance From Wall (in.)</u>
1	1.75

Cross Section of the Inlet  
Bluewater Gas Storage, LLC

Figure 1



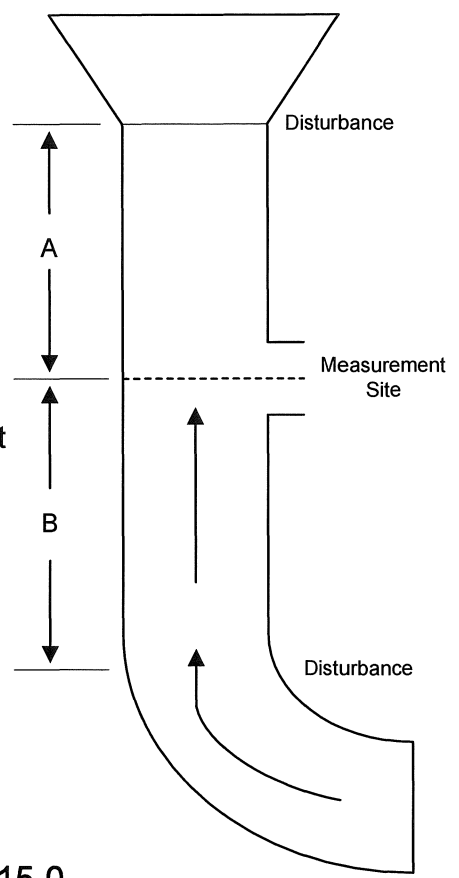
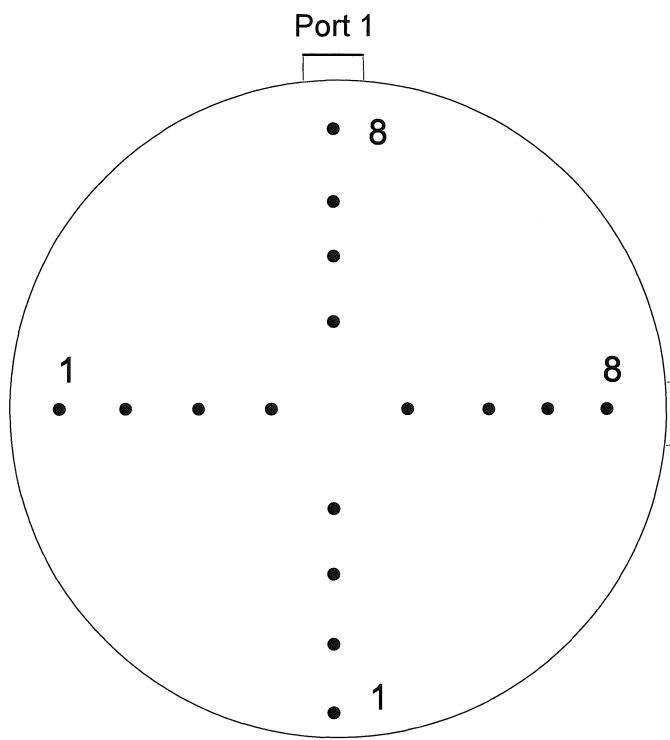

Diameter (in.)	15.0
Port Length (in.)	5.0
Distance A (Duct Diameters)	19.5
Distance B (Duct Diameters)	4.8

<u>Point</u>	<u>Distance From Wall (in.)</u>
1	0.5
2	1.6
3	2.9
4	4.9
5	10.2
6	12.1
7	13.4
8	14.5

Cross Section of the Outlet  
Bluewater Gas Storage, LLC

Figure 2



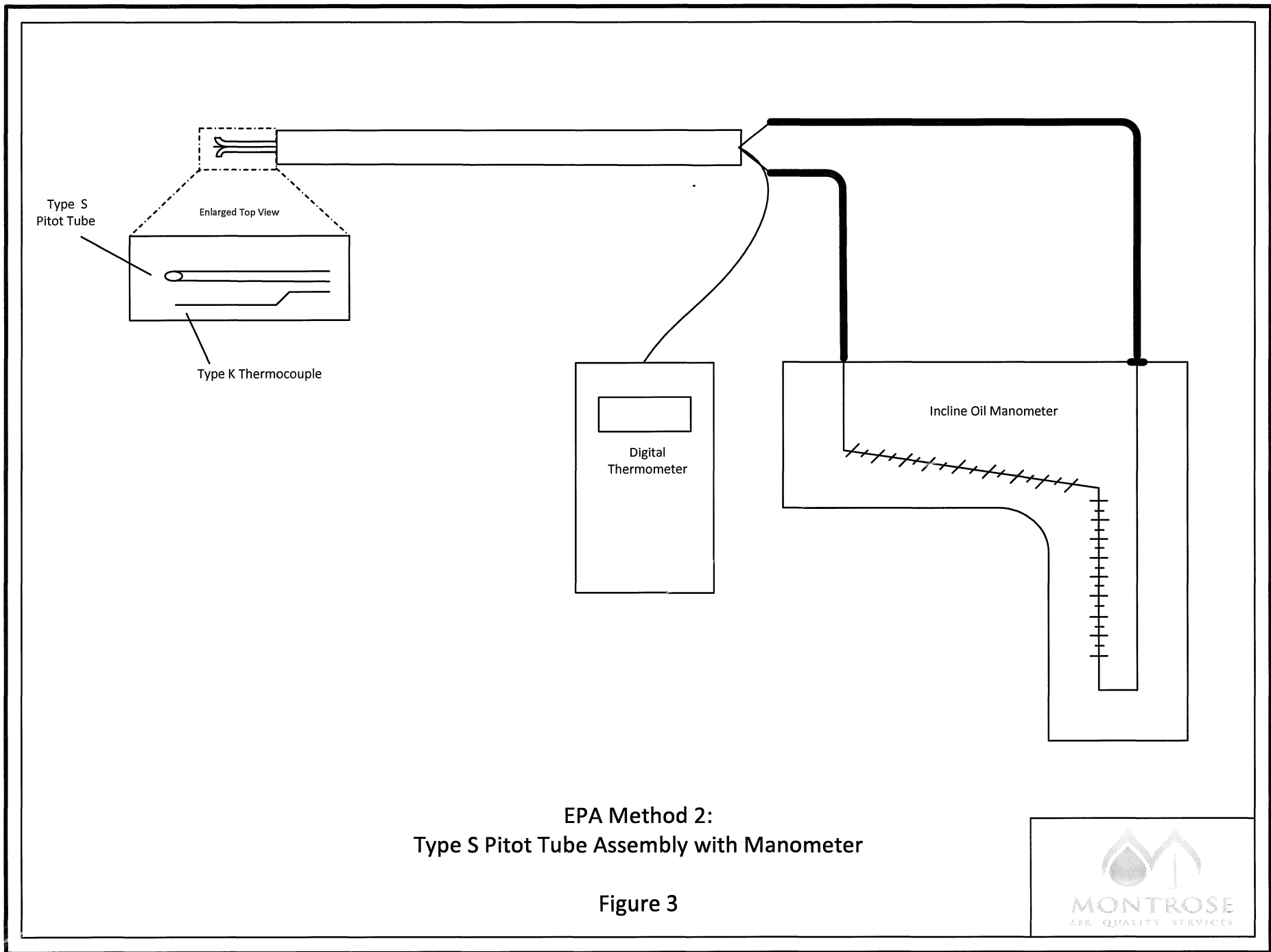

EPA Method 2:  
Type S Pitot Tube Assembly with Manometer

Figure 3





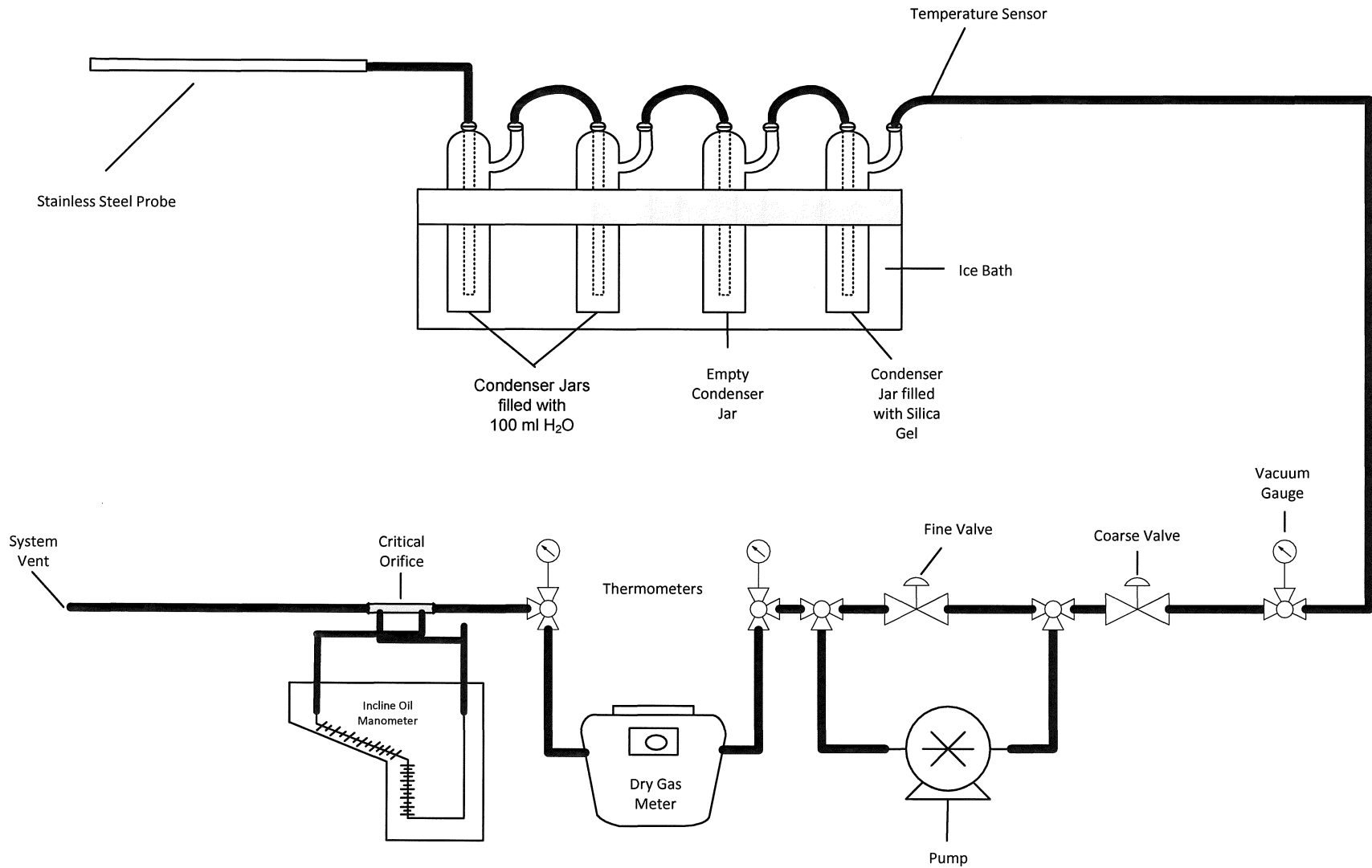

EPA Method 4:  
Moisture Sampling Train

Figure 3



