

Report to

**SCIENTIFIC CONTROL LABORATORIES, INC.**  
Chicago, Illinois

for

**TOTAL CHROMIUM AIR EMISSIONS TESTING**

of the

**CHROME ETCH TANKS & DECORATIVE CHROME PLATING TANKS**  
with

**2 EMISSIONS CONTROL SYSTEM STACKS (SVK2 & SVK8)**

**PLASTIC PLATING - KRAFT AVENUE PLANT (SRN N7374)**  
**LACKS ENTERPRISES, INC.**  
Grand Rapids, Michigan

April 20-21, 2023

***ETE***

## EXECUTIVE SUMMARY

On April 20 and 21, 2023, Environmental Technology & Engineering Corp (ETE) personnel visited the Plastic Plate - Kraft (of Lacks Enterprises, Inc.) facility located at 5675 Kraft Avenue SE in Grand Rapids, Michigan (SRN N7374). The purpose of the visit was to perform air emissions testing for compliance demonstration with the total chromium air emissions limits for the emissions control system on chromium etch tanks (stack SVK2) and the emissions control system on three decorative chrome plating tanks (SVK8). The air emissions limits were contained in Michigan Dept. of Environmental, Great Lakes, & Energy Air Quality Division renewable permit MI-ROP-N7374-2020 and permit to install MI-PTI-N7374-2020.

The results of the testing on stack SVK2 indicated total chromium levels below (in compliance with) the total chromium air emissions limits as shown below:

Stack Tested	Air Emissions Control System	Test Date	Test	Total Chromium Concentration	Total Chromium Emissions Rate
SVK2	3 stage composite mesh pad	4/21	1	0.00801 mg/dscm	0.00130 lb/hr
			2	0.00814 mg/dscm	0.00130 lb/hr
			3	0.00650 mg/dscm	0.00105 lb/hr
			AVG	0.00755 mg/dscm	0.00122 lb/hr
<b>Applicable Air Emissions Limits -</b>				<b>0.016 mg/dscm</b>	<b>0.0032 lb/hr</b>
<b>Results % of Limit -</b>				<b>47.2 %</b>	<b>38.1 %</b>

**Notes:** mg/dscm means milligrams of total chromium per dry standard cubic meter of exhaust

The results of the testing on stack SVK8 indicated total chromium levels below (in compliance with) the total chromium air emissions limits as shown below:

Stack Tested	Air Emissions Control System	Test Date	Test	Total Chromium Concentration	Total Chromium Emissions Rate
SVK8	3 stage composite mesh pad	4/20	1	0.000841 mg/dscm	0.000123 lb/hr
			2	0.000628 mg/dscm	0.000092 lb/hr
			3	0.000561 mg/dscm	0.000081 lb/hr
			AVG	0.000677 mg/dscm	0.000099 lb/hr
<b>Applicable Air Emissions Limits -</b>				<b>0.006 mg/dscm</b>	<b>0.003 lb/hr</b>
<b>Results % of Limit -</b>				<b>11.3 %</b>	<b>3.3 %</b>

**Notes:** mg/dscm means milligrams of total chromium per dry standard cubic meter of exhaust

## 1.0 GENERAL BACKGROUND

On April 20 and 21, 2023, Environmental Technology & Engineering Corp (ETE) personnel visited the Plastic Plate - Kraft (of Lacks Enterprises, Inc.) facility located at 5675 Kraft Avenue SE in Grand Rapids, Michigan (SRN N7374). The purpose of the visit was to perform air emissions testing for compliance demonstration with the total chromium air emissions limits for the emissions control system on chromium etch tanks (stack SVK2) and the emissions control system on three decorative chrome plating tanks (SVK8). The air emissions limits were contained in Michigan Dept. of Environmental, Great Lakes, & Energy Air Quality Division renewable permit "MI-ROP-N7374-2020" and permit to install "MI-PTI-N7374-2020."

The Plastic Plate - Kraft facility is an electroplating facility specializing in nickel and chromium plating for the automotive industry. The operations targeted for testing in this project involved a set of chromium etch process tanks and a set of three decorative chrome plating tanks. Various sizes and shapes of plastic parts are etched in an acidic solution and then are plated with chromium. These parts are placed on bars as part of the production process; bar count is the common means to quantify production rates. Emissions from each set of tanks are captured through two ventilation systems. For each system, the exhaust gas is drawn through a process-specific three stage composite mesh pad control system (CMP). The CMP control system for the chromium etch tanks is exhausted through stack SVK2 to atmosphere; the CMP control system for the decorative chrome plating tanks is exhausted through stack SVK8 to atmosphere.

Plastic Plate - Kraft personnel monitored the operations and emissions control device parameters throughout the test efforts. Those detailed notes are included in Appendix A of this report. It should be noted that although three etch tanks were permitted, only two were in operation during these test efforts on SKV2. The test times and associated data are summarized as follows:

Test Date	Stack Tested	Test	Test Period	Process Bar Count	CMP Scrubber Pressure Drop	Tanks Surface Tensions Range
4/21	SVK2	1	08:30 - 10:32	62	2.9 in. H <sub>2</sub> O	52 - 53 dynes/cm
		2	11:08 - 13:10	62	2.9 in. H <sub>2</sub> O	52 - 53 dynes/cm
		3	13:45 - 15:47	61	2.9 in. H <sub>2</sub> O	49 - 53 dynes/cm
4/20	SVK8	1	10:30 - 12:35	63	3.5 in. H <sub>2</sub> O	39 - 41 dynes/cm
		2	13:13 - 15:16	62	3.6 in. H <sub>2</sub> O	39 - 40 dynes/cm
		3	15:45 - 17:47	60	3.6 in. H <sub>2</sub> O	40 dynes/cm

Ms. Karen Baweja of Lacks Enterprises and Mr. Jeff Zak of Scientific Control Laboratories facilitated in the coordination of the process activities and field test efforts. Mr. Trevor Drost and Ms. April Lazzaro of Michigan EGLE-AQD witnessed the test efforts and production activities. The field test efforts were performed by ETE personnel; Michael Huenink was the test team leader. The analysis for total chromium content in the sample solutions was performed by Element One, Inc. (Wilmington, NC).

## 2.0 RESULTS

Testing to determine total chromium "Cr" levels in the stack exhaust was performed isokinetically using EPA Methods 1 through 4 and 306. A brief description of the method is included in Section 3.0 of this report. Sketches showing the sampling port and point locations at each test location are included as Figures 2-1 (SVK2) and 2-2 (SVK8).

The stack flow parameters measured during testing and the weights of the total Cr collected were used to determine the emissions for each test. Three separate 120 minute tests were performed on each stack. The chromium emission results for both stacks are included as Table 2-1; the detailed isokinetic data and calculations for the runs are included in Appendix B of this report. The full analytical report is included as Appendix C of this report; however, the best results summary can be observed on page 4 of that lab report.

The results of the testing on stack SVK2 indicated total chromium levels below (in compliance with) the total chromium air emissions limits as shown below:

Stack Tested	Air Emissions Control System	Test Date	Test	Total Chromium Concentration	Total Chromium Emissions Rate
SVK2	3 stage composite mesh pad	4/21	1	0.00801 mg/dscm	0.00130 lb/hr
			2	0.00814 mg/dscm	0.00130 lb/hr
			3	0.00650 mg/dscm	0.00105 lb/hr
			<b>AVG</b>	<b>0.00755 mg/dscm</b>	<b>0.00122 lb/hr</b>
<b>Applicable Air Emissions Limits -</b>				<b>0.016 mg/dscm</b>	<b>0.0032 lb/hr</b>
<b>Results % of Limit -</b>				<b>47.2 %</b>	<b>38.1 %</b>

**Notes:** mg/dscm means milligrams of total chromium per dry standard cubic meter of exhaust

The results of the testing on stack SVK8 indicated total chromium levels below (in compliance with) the total chromium air emissions limits as shown below:

Stack Tested	Air Emissions Control System	Test Date	Test	Total Chromium Concentration	Total Chromium Emissions Rate
SVK8	3 stage composite mesh pad	4/20	1	0.000841 mg/dscm	0.000123 lb/hr
			2	0.000628 mg/dscm	0.000092 lb/hr
			3	0.000561 mg/dscm	0.000081 lb/hr
			<b>AVG</b>	<b>0.000677 mg/dscm</b>	<b>0.000099 lb/hr</b>
<b>Applicable Air Emissions Limits -</b>				<b>0.006 mg/dscm</b>	<b>0.003 lb/hr</b>
<b>Results % of Limit -</b>				<b>11.3 %</b>	<b>3.3 %</b>

**Notes:** mg/dscm means milligrams of total chromium per dry standard cubic meter of exhaust

**CHROMIUM ETCH TANKS - CONTROL SYSTEM (SVK2)  
 PLASTIC PLATE - KRAFT AVENUE**

**FIGURE 2-1**

**SAMPLE POINT LOCATIONS**

<u>Point</u>	<u>Distance (in.) from back wall</u>
1	1.3
2	4.0
3	7.1
4	10.6
5	15.0
6	21.4
7	38.6
8	45.0
9	49.4
10	52.9
11	56.0
12	58.7

**SAMPLE PORT LOCATION**

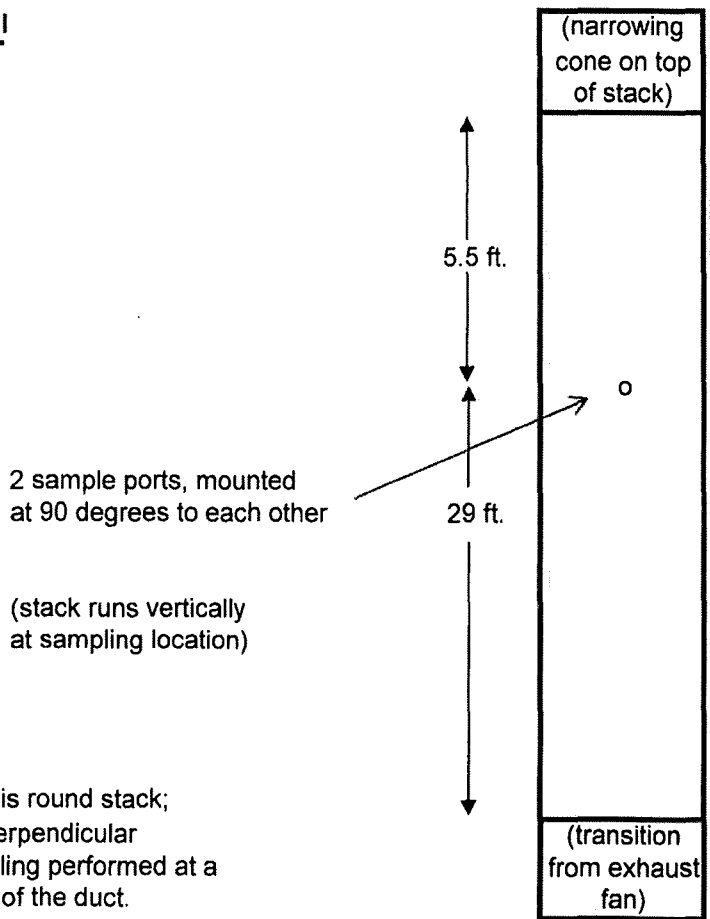

**Stack Diameter:** 60 in. (stack runs vertically at sampling location)

**Notes:** 24 sampling points used on this round stack; 12 points along each of two perpendicular traverses. All other gas sampling performed at a single point in the center third of the duct.

**RECEIVED**

**JUN 20 2023**

**AIR QUALITY DIVISION**

**DECORATIVE CR PLATING TANKS - CONTROL SYSTEM (SVK8)  
 PLASTIC PLATE - KRAFT AVENUE**

**FIGURE 2-2**

**SAMPLE POINT LOCATIONS**

<u>Point</u>	<u>Distance (in.) from back wall</u>
1	1.1
2	3.5
3	6.1
4	9.2
5	13.0
6	18.5
7	33.5
8	39.0
9	42.8
10	45.9
11	48.5
12	50.9

**SAMPLE PORT LOCATION**

2 sample ports, mounted  
at 90 degrees to each other

**Stack Diameter:** 52 in. (stack runs vertically  
at sampling location)

**Notes:** 24 sampling points used on this round stack;  
 12 points along each of two perpendicular  
 traverses. All other gas sampling performed at a  
 single point in the center third of the duct.

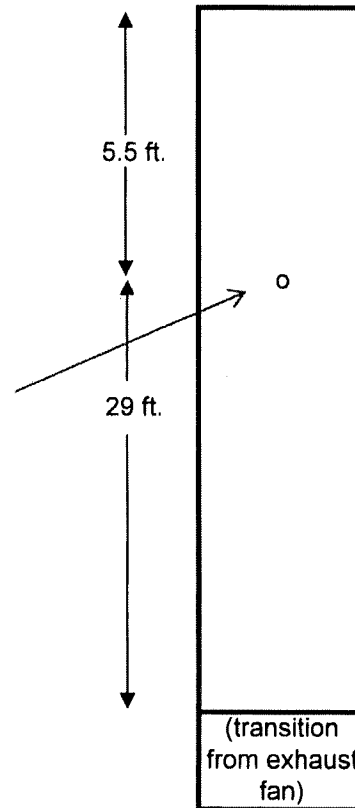

**CR TEST RESULTS**

**Chromium Control System Stacks (SVK2 & SVK8)**

**Plastic Plate - Kraft (Lacks)**

**April 20 & 21, 2023**

**TABLE 2-1**

Sample Location	Test	Sample Total Cr Amount (mg)	Standard Sample Volume (ft3)	Standard Sample Volume (dscm)	Corrected Total Cr Concn. (mg/dscm)	Standard Exhaust Flow Rate (dscfm)	Standard Exhaust Flow Rate (m3/hr)	Total Cr Emission Rate (lb/hr)
SVK2	1	0.0186	81.97	2.321	0.00801	43255	73491	0.00130
	2	0.0187	81.13	2.297	0.00814	42772	72670	0.00130
	3	0.0151	82.09	2.325	0.00650	42998	73054	0.00105
	<b>3 Test AVG -</b>					<b>0.00755</b>	<b>43008</b>	<b>73072</b>
<b>Applicable Permit Limits -</b>					<b>0.016 mg/dscm</b>			<b>0.0032 lb/hr</b>
SVK8	1	0.00234	98.22	2.781	0.000841	38967	66206	0.000123
	2	0.00177	99.46	2.816	0.000628	38899	66090	0.000092
	3	0.00156	98.26	2.782	0.000561	38652	65671	0.000081
	<b>3 Test AVG -</b>					<b>0.000677</b>	<b>38839</b>	<b>65989</b>
<b>Applicable Permit Limits -</b>					<b>0.006 mg/dscm</b>			<b>0.003 lb/hr</b>

**Notes:** Std. Sample Vol (dscm) = Std. Sample Vol (ft3) x 0.028317  
 Total Cr Concn. (mg/dscm) = Sample Total Cr Amount (mg) / Std. Sample Vol. (dscm)  
 Std. Exh. Flow Rate (m3/hr) = Std Exh Flow Rate (dscfm) x 60 min/hr x 0.028317 m3/ft3  
 Emission Rate = [Concn.(mg/m3) x Exhaust Flow(mg/m3)] x [1 lb / 453600 mg]

### 3.0 TEST METHODS

The equipment used to sample total chromium was the Western Precipitation Division of the Joy Manufacturing Company Emission Parameter Analyzer (Method 5 sample train). Samples were collected and analyzed in accordance with procedures outlined in EPA Method 306.

The sampling train consisted of a glass probe tip, a glass lined probe, and PVC connective tubing. A series of four impingers followed in an ice bath. The first was a modified Greenburg-Smith impinger with 100 ml of 0.1 N sodium hydroxide (NaOH); the second was a Greenburg-Smith impinger with 100 ml of 0.1 N NaOH; the third was a modified Greenburg-Smith impinger dry; the fourth was also a modified Greenburg-Smith impinger containing a tared quantity of Silica Gel. The gas then passed through a vacuum pump, calibrated dry gas meter, and a calibrated orifice. A schematic drawing of the sampling train is included.

The temperatures of the stack gas stream, as well as strategic locations within the sampling devices, were monitored by RTDs and read directly from a gauge on the control unit. The initial gas stream velocity was obtained from a preliminary traverse using a Pitot tube. The initial moisture was estimated from previous tests of similar processes. This data, along with the stack temperature, was used to set a nomograph so that rapid calculations of isokinetic sampling conditions could be made.

The principle of the method was to collect the sample representative of the exhaust by adjusting the sample collection velocity to match the exhaust gas stream velocity at the point of collection. The velocity at the point of collection was measured with an "S" type Pitot tube and the collection velocity was matched to the stack gas velocity by adjusting the flow as indicated by the calibrated orifice.

To determine the molecular weight of the stack gas, samples were drawn into an Orsat analyzer and analyzed for percentage CO<sub>2</sub>, O<sub>2</sub>, CO, and N<sub>2</sub>.

At the completion of the test, the impinger contents were measured and weighed for determination of the actual moisture content of the exhaust gas stream. The impinger contents were then placed in a clean glass jar with Teflon-lined cap. The probe tip, probe, and connective tubing were then rinsed with 0.1 N NaOH (100 ml total) into the sampling train. That rinse was also placed in the sample jar. The impingers were then rinsed twice more with 0.1 N NaOH (100 ml) and the rinses were also added to the sample jar. The samples were refrigerated prior to analysis.

The sample solutions were analyzed for total Cr content by ICP-MS using the analytical methods contained in EPA Method 306. Field blanks of the sample solutions were also analyzed and all results were blank corrected. For those samples analyzed in duplicate, the average of the two results was used in the final emissions calculations.



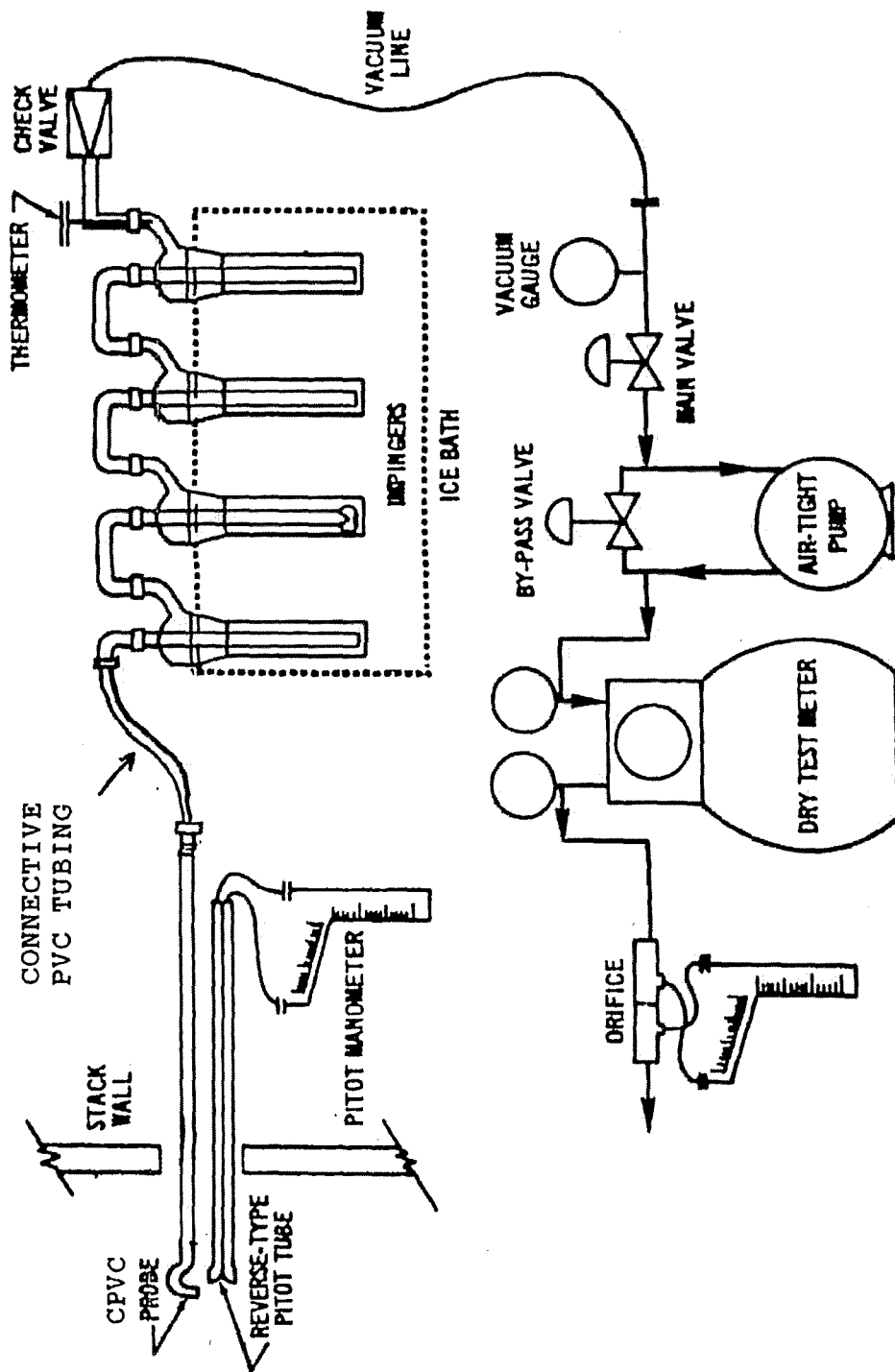

EPA METHOD 306

TOTAL CHROMIUM EMISSIONS  
SAMPLING TRAIN

#### 4.0 CALIBRATION DATA

The probe tips, Pitot tubes, dry gas meters, and sample box orifices were calibrated prior to the testing in accordance with the procedures outlined in the Maintenance, Calibration, and Operation of Isokinetic Source-Sampling Equipment as published by the US EPA. The values obtained were:

Stack/ Test Location	Date	Control Box ID	Orifice Coeff. ( $\Delta H@$ )	Dry Gas Meter Coeff. ( $\gamma$ )	Probe Tip Diameter
SVK2 (etch)	4/21	4	1.759	0.991	0.250 in.
SVK8 (decorative plating)	4/20	4	1.759	0.991	0.250 in.

The most recent calibrations on the sampling equipment were performed on March 31, 2023.

The isokinetic ratios for the SVK2 test runs were in the range of 91.0 to 91.6 percent; the isokinetic ratios for the SVK8 test runs were in the range of 91.5 to 92.2 percent. All of the isokinetic sampling ratios were within the acceptable range of 90 to 110 percent.

The flow measurements were made with an S-type Pitot tube which had a verified Pitot tube coefficient ( $C_p$ ) of 0.84. Prior to the sampling efforts on the stack, the "null" angles were measured for a determination of the absence or presence of cyclonic flow. For SVK2, those measurements indicated null angles in the range of 0 to 5 percent, with the average of 2.1 degrees falling well within the 20 percent criteria for acceptable sampling locations. For SVK8, those measurements indicated null angles in the range of 0 to 10 percent, with the average of 3.1 degrees falling well within the 20 percent criteria for acceptable sampling locations.

The quality control data from the sample analysis is included in the detailed analytical report.