

1.0 EXECUTIVE SUMMARY

Mostardi Platt conducted a compliance emissions test program for Marquette Board of Light and Power (MBLP) on July 7, 2021 at the Marquette Energy Center (MEC) on the Reciprocating Internal Combustion Engine 3 (EU-ENGINE03) Outlet Duct in Marquette, Michigan. The purpose of the test program was to meet the compliance demonstration requirements for emission rate in accordance with Permit Number MI-ROP-P0668-2019, 40 CFR Part 60 Subpart JJJJ, and 40 CFR Part 60 Subpart IIII.

The test location, test date, and test parameters are summarized below.

Test Location	Test Date	Test Parameters
EU-ENGINE03 Outlet Duct	July 7, 2021	Nitrogen Oxides (NO _x), Carbon Monoxide (CO), Carbon Dioxide (CO ₂), Oxygen (O ₂), Volatile Organic Concentration (VOC), Formaldehyde (CH ₂ O), Volumetric Flow, and Moisture

MBLP has installed a dual-fuel Wärtsilä 18V50DFm four stroke, lean burn 17 MW (nominal) engine (173 mmBtu/hr when firing natural gas as primary fuel, 154 mmBtu/hr when firing emergency backup fuel oil), compression ignition RICE used for electrical generation. The RICE electric generating unit utilizes pipeline quality natural gas and is equipped with selective catalytic reduction (SCR) for nitrogen oxides (NO_x) control and an oxidation catalyst system for carbon monoxide (CO), volatile organic compound (VOC), and organic hazardous air pollutant (HAP) control. The RICE electric generating unit exhausts into an individual stack.

Selected results of the test program are summarized below. A complete summary of emission test results follows the narrative portion of this report.

Source	Fuel	Parameter	Emission Limit	Test Results
EU-ENGINE03 Outlet Duct	Natural Gas	NO _x	3.3 lb/hr	0.47 lb/hr
			1.0 g/HP-hr or 82 ppmvd@15% O ₂	0.009 g/HP-hr, 0.9 ppmvd@15% O ₂
		CO	5.0 lb/hr	0.28 lb/hr
			2.0 g/HP-hr or 270 ppmvd@15% O ₂	0.006 g/HP-hr, 0.9 ppmvd@15% O ₂
		VOC	16.5 lb/hr	6.28 lb/hr
			0.7 g/HP-hr or 60 ppmvd@15% O ₂	0.12 g/HP-hr, 12.2 ppmvd@15% O ₂
CH ₂ O	0.648 lb/hr	0.18 lb/hr		

The identifications of the individuals associated with the test program are summarized below.

TEST PERSONNEL INFORMATION		
Location	Address	Contact
Test Coordinator/ Test Facility	Marquette Board of Light and Power Marquette Energy Center 2200 Wright Street Marquette, Michigan 49855	Mr. Thomas J. Skewis Environmental Technician (906) 225-8670 (office) tskewis@mblp.org
Testing Company Representative	Mostardi Platt 888 Industrial Drive Elmhurst, Illinois 60126	Mr. Stuart Sands Senior Project Manager (630) 993-2100 (phone) ssands@mp-mail.com

The test crew consisted of Messrs. J. Carlson and S. Sands.

2.0 TEST METHODOLOGY

Emission testing was conducted following the methods specified in Code of Federal Regulations, Title 40, Part 60, Appendix A (40CFR60) and 40CFR63. Schematics of the test section diagrams and sampling trains used are included in Appendix A and B, respectively. Calculation examples and nomenclature are included in Appendix C. Copies of analyzer print-outs and field data sheets for each test run are included in Appendices D and E, respectively.

The following methodologies were used during the test program:

Method 1 Traverse Point Determination

Test measurement points were selected in accordance with Method 1. The characteristics of the measurement location are summarized below.

TEST POINT INFORMATION						
Location	Diameter (Feet)	Area (Square Feet)	Upstream Distance (Inches)	Downstream Distance (Inches)	Test Parameter	Number of Sampling Points
EU-ENGINE03 Outlet Duct	5.25	21.65	>0.5	>2.0	Volumetric Flow	16
					NO _x /CO/VOC/ O ₂ /CO ₂	12 (stratification test), 1 (Runs 1 through 3)

Method 2 Volumetric Flowrate Determination

Gas velocity was measured following Method 2, for purposes of calculating stack gas volumetric flow rate. An S-type pitot tube, differential pressure gauge, Thermal couple and temperature readout were used to determine gas velocity at each sample point. All of the equipment used was calibrated in accordance with the specifications of the Method. Calibration data are presented in Appendix F.

Method 3A Oxygen (O₂)/Carbon Dioxide (CO₂) Determination

Flue gas O₂ was determined in accordance with Method 3A. An ECOM analyzer was used to determine stack gas oxygen content connected to the outlet of the FTIR analyzer.

Flue gas carbon dioxide concentrations and emission rates were determined in accordance with Method 3A. An MKS MultiGas 2030 FTIR spectrometer was used to determine the CO₂ concentrations, in the manner specified in the Method. Nitrogen Content was determined from the difference of CO₂ and O₂.

Stack gas was delivered to the analyzer via a Teflon® sampling line, heated to a minimum temperature of 375°F. The entire system was calibrated in accordance with the Method, using certified calibration gases introduced at the probe, before and after each test run.

All of the equipment used was calibrated in accordance with the specifications of the Method and calibration data are included in Appendix F. Copies of the gas cylinder certifications are included in Appendix H.

Method 7E Nitrogen Oxide (NO_x) Determination

Flue gas NO_x concentrations and emission rates were determined in accordance with Method 7E. An MKS MultiGas 2030 FTIR spectrometer was used to determine nitrogen oxide concentrations, in the manner specified in the Method.

Stack gas was delivered to the analyzer via a Teflon® sampling line, heated to a minimum temperature of 375°F. The entire system was calibrated in accordance with the Method, using certified calibration gases introduced at the probe, before and after each test run.

A list of calibration gases used and the results of all calibration and other required quality assurance checks can be found in Appendix F. Copies of calibration gas certifications can be found in Appendix H.

Method 10 Carbon Monoxide (CO) Determination

Flue gas CO concentrations and emission rates were determined in accordance with Method 10. An MKS MultiGas 2030 FTIR spectrometer was used to determine carbon monoxide concentrations, in the manner specified in the Method.

Stack gas was delivered to the analyzer via a Teflon® sampling line, heated to a minimum temperature of 375°F. The entire system was calibrated in accordance with the Method, using certified calibration gases introduced at the probe, before and after each test run.

A list of calibration gases used and the results of all calibration and other required quality assurance checks can be found in Appendix F. Copies of calibration gas certifications can be found in Appendix H.

Method 25A Volatile Organic Compound (VOC) Determination

Total hydrocarbon (THC) concentrations and emission rates were determined in accordance with Method 25A. Stack gas was delivered to the system via a Teflon® sampling line, heated to a minimum temperature of 375°F.

Methane and ethane concentrations were determined in accordance with Method 320 and then subtracted from the THC concentrations in order to determine VOC emissions.

The system was calibrated before and after each test run using certified calibration gases of propane for the THC determination. Calibration data are presented in Appendix F, field sheets are presented in Appendix D, and copies of gas certifications are presented in Appendix H.

Method 320 Fourier Transform Infrared (FTIR) Detector for Methane, Ethane, Formaldehyde, and Moisture Determination

Flue gas methane, ethane, formaldehyde, and moisture concentrations and emission rates were determined in accordance with Method 320. FTIR data was collected using an MKS MultiGas 2030 FTIR spectrometer. The FTIR was equipped with a temperature-controlled, 5.11 meter multi-pass gas cell maintained at 191°C. Gas flows and sampling system pressures were monitored using a rotameter and pressure transducer.

All data was collected at 0.5 cm⁻¹ resolution. Each spectrum was derived from the coaddition of 62 scans, with a new data point generated approximately every one minute. Analyzer data for each run is present in Appendix D.

SAMPLING SYSTEM PARAMETERS				
MKS Serial #	Sampling Line	Probe Assembly	Particulate Filter Media	Operating Temperatures
019088128	100' 3/8" dia., heated Teflon	Heated 3', 3/8" dia. SS	0.01µ heated borosilicate glass fiber	191°C

QA/QC procedures followed US EPA Method 320. See below for QA/QC procedure details and list of calibration gas standards. All calibration gases were introduced to the analyzer and the sampling system using an instrument grade stainless steel rotameter. All QA/QC procedures were within the acceptance criteria allowance of the applicable EPA methodology. See Appendix G for FTIR QA/QC Data.

FTIR QA/QC PROCEDURES						
QA/QC Specification	Purpose	Calibration Gas Analyte	Delivery	Frequency	Acceptance Criteria	Result
M320: Zero	Verify that the FTIR is free of contaminants & zero the FTIR	Nitrogen (zero)	Direct to FTIR	pre/post test	< MDL or Noise	Pass
M320: Calibration Transfer Standard (CTS) Direct	Verify FTIR stability, confirm optical path length	Ethylene	Direct to FTIR	pretest	+/- 5% cert. value	Pass
M320: Analyte Direct	Verify FTIR calibration	Methanol, Acetaldehyde, Sulfur Hexafluoride	Direct to FTIR	pretest	+/- 5% cert. value	Pass
M320: CTS Response	Verify system stability, recovery, response time	Ethylene	Sampling System	Daily, pre/post test	+/- 5% of Direct Measurement	Pass
M320: Zero Response	Verify system is free of system bias	Nitrogen (zero)	Sampling System	pretest	Bias correct data	Pass
M320: Analyte Spike	Verify system ability to deliver and quantify analyte of interest in the presence of effluent gases	Methanol, Acetaldehyde, Sulfur Hexafluoride	Dynamic Addition to Sampling System, 1:10 effluent	Throughout testing – daily	+/- 30% theoretical recovery	Pass

Note: The determined concentrations from direct analyses were used in all system/spike recovery calculations.

CALIBRATION GAS STANDARDS				
Components	Concentration (ppm)	Vendor	Cylinder #	Standard Type
Ethylene	99.41	Airgas	CC234526	Primary +/- 1%
Methanol Acetaldehyde SF ₆	198.0 205.9 5.122	Airgas	SG9159486BAL	Certified Standard-Spec +/- 5%
Nitrogen	Zero Gas	Airgas	N/A	UHP Grade

Analyte Spiking

Acetaldehyde/Methanol spiking was performed prior to testing to verify the ability of the sampling system to quantitatively deliver a sample containing Formaldehyde from the base of the probe to the FTIR. Analyte spiking assures the ability of the FTIR sampling system to recover volatile organics in the presence of effluent gas.

As part of the spiking procedure, samples were measured to determine native formaldehyde concentrations to be used in the spike recovery calculations. The analyte spiking gases contained Nitrous Oxide (N₂O). The determined N₂O concentration in the spiked sample was used to calculate the dilution factor of the spike and thus used to calculate the concentration of the spiked formaldehyde. The spike target dilution ratio was 1:10 or less.

The following equation illustrates the percent recovery calculation.

$$DF = \frac{SF_6(spik)}{SF_6(direct)} \quad (\text{Sec. 9.2.3 (3) USEPA Method 320})$$

$$CS = DF * Spike(dir) + Unspike(1 - DF) \quad (\text{Sec. 9.2.3 (4) USEPA Method 320})$$

- DF = Dilution factor of the spike gas
- SF_{6(dir)} = SF₆ concentration measured directly in undiluted spike gas
- SF_{6(spik)} = Diluted SF₆ concentration measured in a spiked sample
- Spike_{dir} = Concentration of the analyte in the spike standard measure by the FTIR directly
- CS = Expected concentration of the spiked samples
- Unspike = Native concentration of analytes in unspiked samples

Post Collection Data Validation

As part of the data validation procedure, reference spectra are manually fit to that of the sample spectra and a concentration is determined. The reference spectra are scaled to match the peak amplitude of the sample, thus providing a scale factor. The scale factor multiplied by the reference spectra concentration is used to determine the concentration value for the sample spectra. Sample pressure and temperature corrections are then applied to compute the final sample concentration. The manually calculated results are then compared with the software-generated results. The data is then validated if the two concentrations are within ± 20% agreement. If there is a difference greater than ± 20% the spectra are reviewed for possible spectra interferences or any other possible causes leading to incorrectly quantified data.

Detection Limit

The detection limit of each analyte was calculated following Annex A2 of ASTM D6348-12 procedure using spectra that contained similar amounts of moisture and carbon dioxide.

Analyte	Detection Limit (ppmv wet)	Detection Limit (%v)
Methane	1.0	-
Ethane	0.5	-
Formaldehyde	0.2	
Moisture	-	0.1

QA/QC data are found in Appendix G. Copies of gas cylinder certifications are found in Appendix H. All concentration data were recorded on a wet, volume basis. The sample and data collection followed the procedures outlined in Method 320.

3.0 TEST RESULT SUMMARY

Marquette Board of Light and Power
 Marquette Energy Center
 EU-ENGINE03
 Gaseous Summary

Test No.	Date	Start Time	End Time	NO _x ppmvd	CO ppmvd	O ₂ % (dry)	CO ₂ % (dry)	Formaldehyde ppmvd	Moisture, %	Flowrate, DSCFM	THC ppm as C ₂ H ₆ (wet)	CH ₄ ppm as CH ₄ (wet)	CH ₄ ppm as C ₂ H ₆ (wet)	C ₂ H ₂ ppm as C ₂ H ₆ (wet)	C ₂ H ₄ ppm as C ₂ H ₆ (wet)	VOC ppm as C ₂ H ₆ (wet)	VOC ppm as C ₂ H ₆ (dry)
1	07/07/21	08:05	09:11	1.5	1.3	11.6	5.3	0.84	10.2	47,036	448.1	1,159.3	413.5	33.5	22.3	12.3	13.7
2	07/07/21	09:45	10:44	1.5	1.4	11.6	5.3	0.81	10.2	47,110	450.8	1,183.9	422.3	28.1	18.7	9.8	10.9
3	07/07/21	11:10	12:09	1.1	1.4	11.6	5.3	0.81	10.2	47,854	467.8	1,167.3	416.3	32.4	21.6	29.9	33.3
Average				1.4	1.4	11.6	5.3	0.82	10.2	47,333	455.6	1,170.2	417.4	31.3	20.9	17.3	19.3

Emission Rate Summary

Test No.	Date	Start Time	End Time	NO _x ppmvd @ 15% O ₂	CO ppmvd @ 15% O ₂	VOC ppmvd @ 15% O ₂ as C ₂ H ₆	Formaldehyde lb/hr	NOx lb/hr	CO lb/hr	VOC lb/hr	Horsepower	NOx g/hp-hr	CO g/hp-hr	NME VOC g/hp-hr
1	07/07/21	08:05	09:11	1.0	0.8	8.7	0.18	0.51	0.27	4.41	22,837.6	0.010	0.005	0.09
2	07/07/21	09:45	10:44	1.0	0.9	6.9	0.18	0.51	0.29	3.53	22,807.0	0.010	0.006	0.07
3	07/07/21	11:10	12:09	0.7	0.9	21.1	0.18	0.38	0.29	10.90	22,786.1	0.008	0.006	0.22
Average				0.9	0.9	12.2	0.18	0.47	0.28	6.28	22,810.2	0.009	0.006	0.12

*Methane is corrected with a Response Factor of 1.07 for the CAI 300 analyzer

4.0 CERTIFICATION

Mostardi Platt is pleased to have been of service to Marquette Board of Light and Power. If you have any questions regarding this test report, please do not hesitate to contact us at 630-993-2100.

As project manager, I hereby certify that this test report represents a true and accurate summary of emissions test results and the methodologies employed to obtain those results, and the test program was performed in accordance with the methods specified in this test report.

MOSTARDI PLATT



Stuart T. Sands Program Manager



Eric L. Ehlers Quality Assurance

RECEIVED

AUG 30 2021

AIR QUALITY DIVISION

APPENDICES

Appendix A - Test Section Diagrams

VOLUMETRIC FLOW TRAVERSE FOR ROUND DUCTS

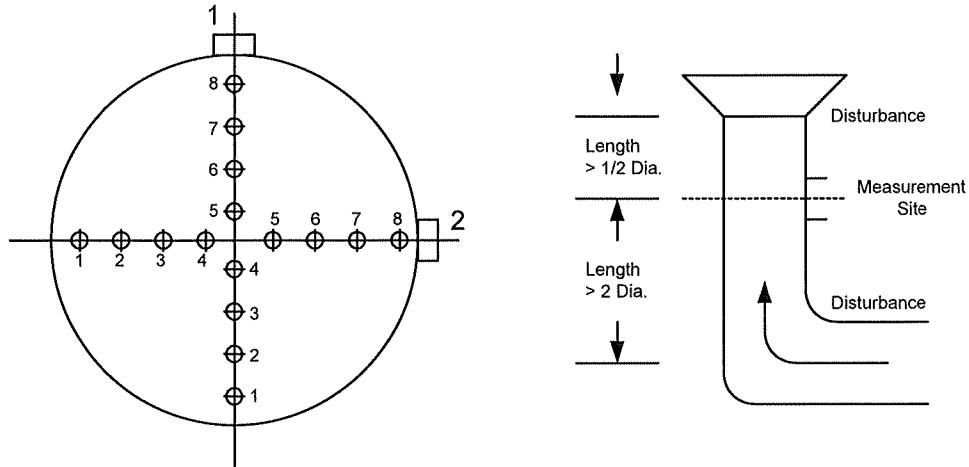

Job: Marquette Board of Light and Power
Marquette Energy Center
Marquette, Michigan

Date: July 7, 2021

Test Location: EU-ENGINE03 Outlet Duct

Duct Diameter: 5.29 Feet

Duct Area: 21.979 Square Feet

No. Points Across Diameter: 6

No. of Ports: 2

Port Length: 8.0 Inches

REPRESENTATIVE POINT FOR GASEOUS RUNS ON ROUND DUCTS

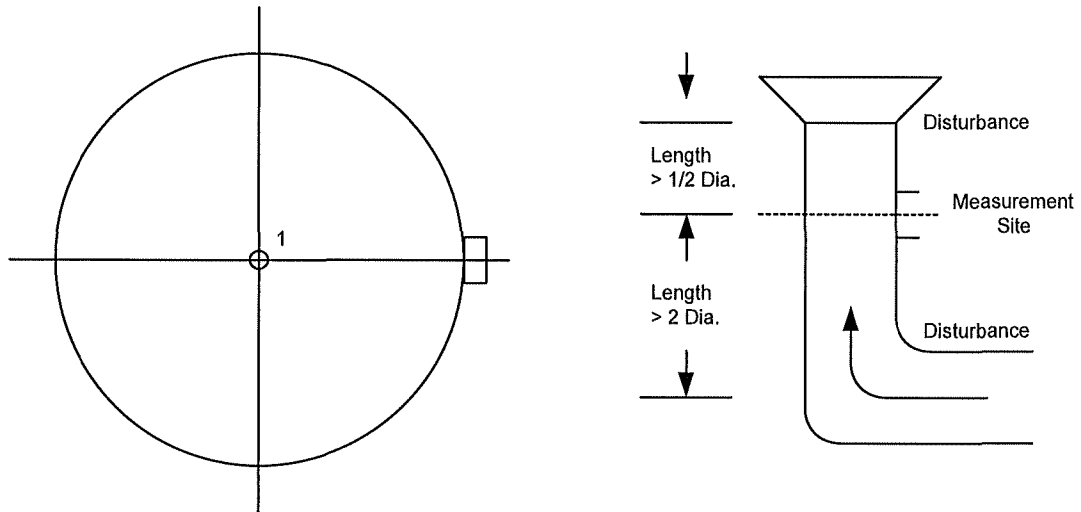

Job: Marquette Board of Light and Power
Marquette Energy Center
Marquette, Michigan

Date: July 7 2021

Test Location: EU-ENGINE03 Outlet Duct

Duct Diameter: 5.29 Feet

Duct Area: 21.979 Square Feet

No. Points Across Diameter: 1

No. of Ports: 1

Port Length: 8.0 Inches

GASEOUS STRATIFICATION TEST FOR ROUND DUCTS

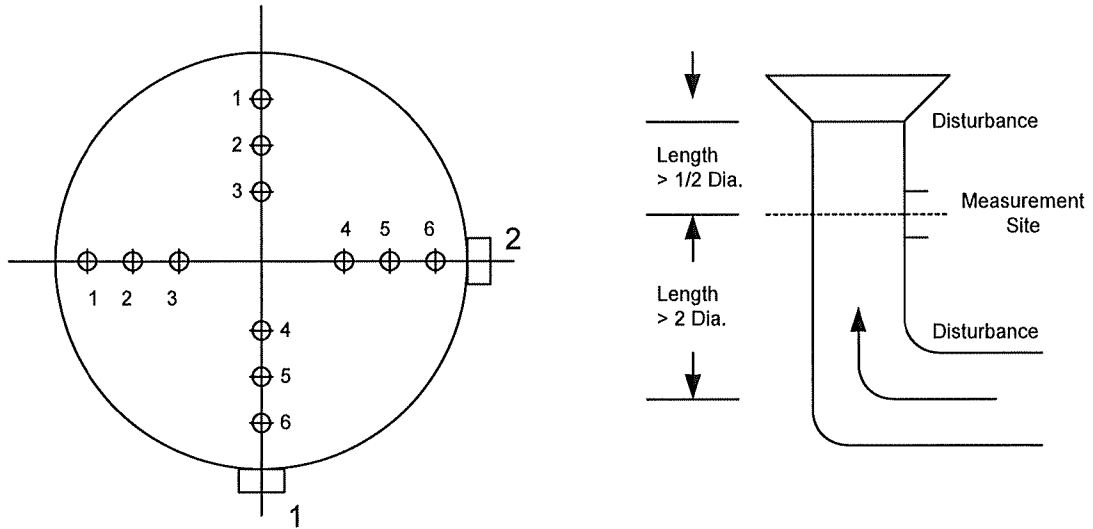

Job: Marquette Board of Light and Power
Marquette Energy Center
Marquette, Michigan

Date: July 7, 2021

Test Location: EU-ENGINE03 Outlet Duct

Duct Diameter: 5.29 Feet

Duct Area: 21.979 Square Feet

No. Points Across Diameter: 6

No. of Ports: 2

Port Length: 8.0 Inches

Appendix B - Sample Train Diagrams

USEPA Method 2 – Type S Pitot Tube Manometer Assembly

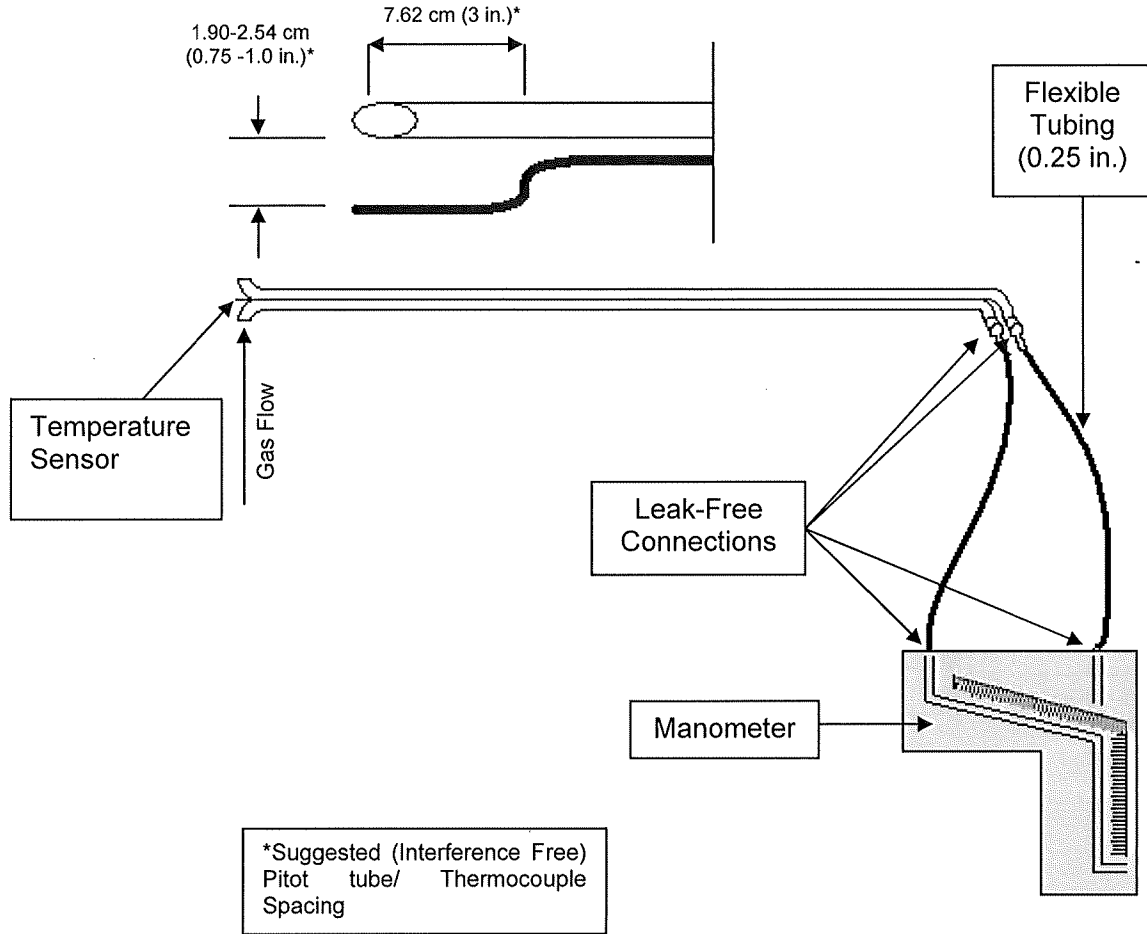

USEPA Methods 3A and 320 – Sample Train Diagram

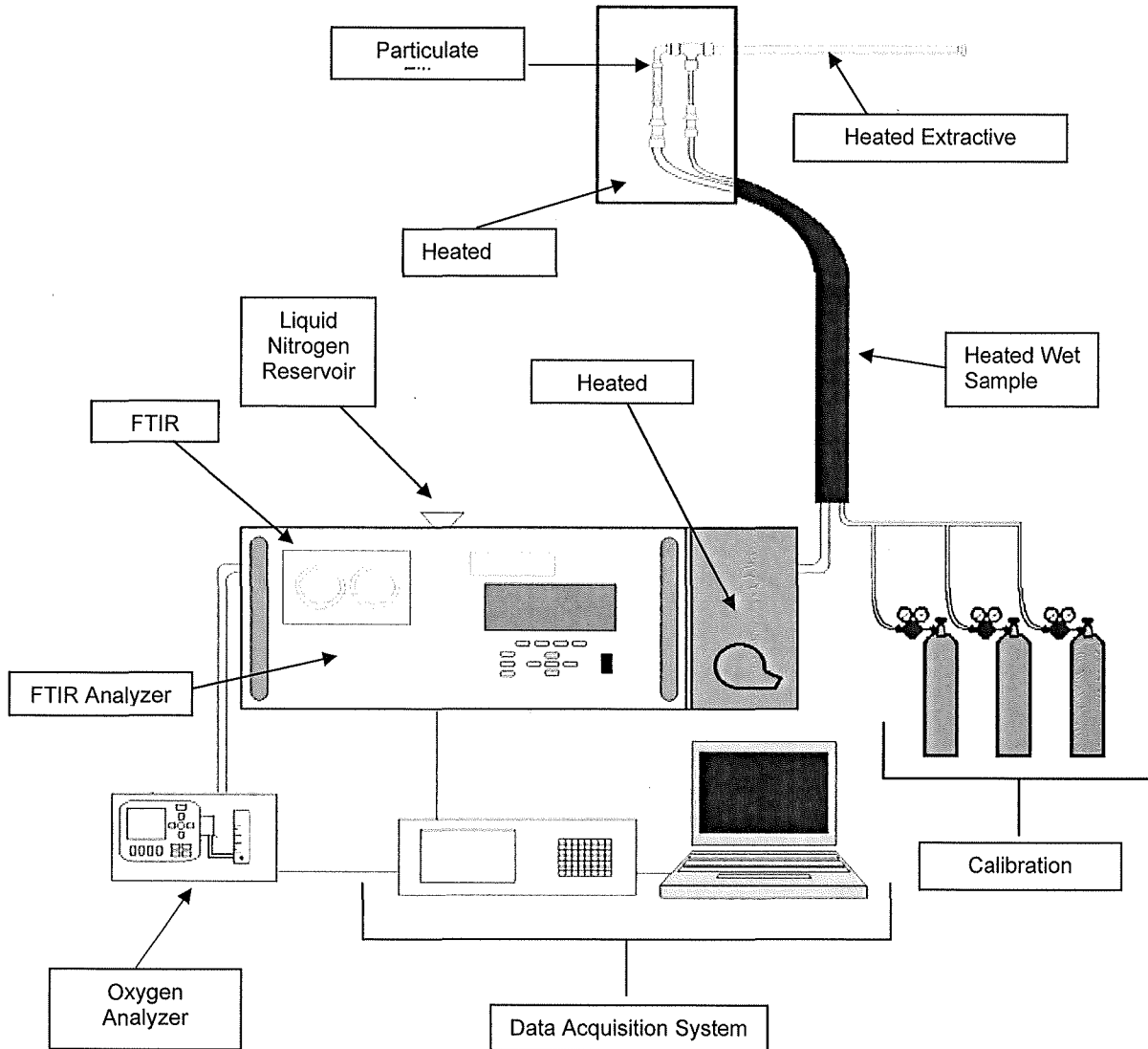

USEPA Method 25A – Total Gaseous Organic Compound Sample Train

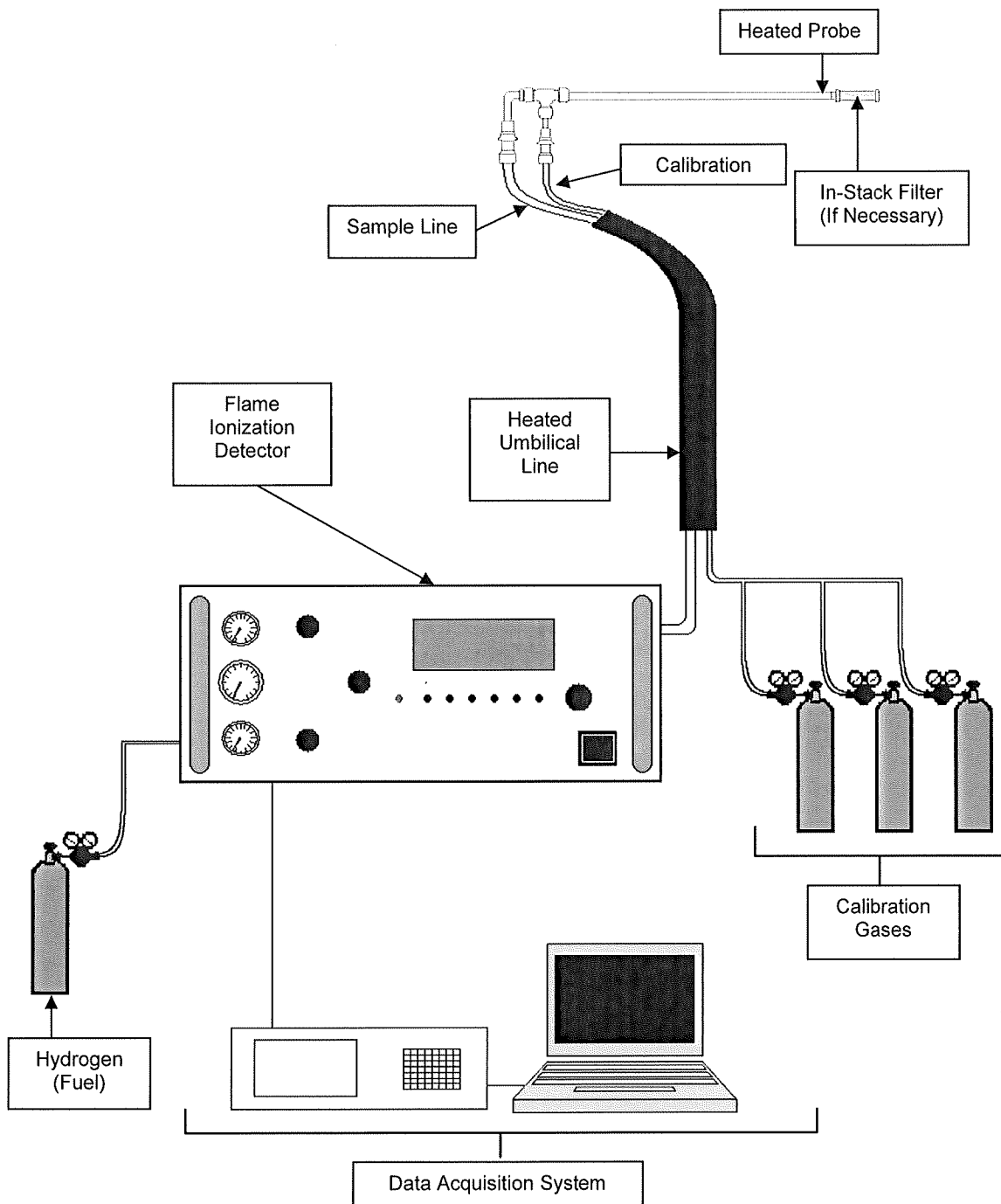

Appendix C - Calculation Nomenclature and Formulas