



P0797

Upper Michigan Energy Resources Corporation  
231 W. Michigan St.  
Milwaukee, WI 53203

**UNITED PARCEL SERVICE**

May 2, 2019

Mr. Joseph Scanlan  
Michigan Department of Environment, Great Lakes, and Energy  
Air Quality Division  
1504 West Washington Street  
Marquette, MI 49855

**Subject: F.D. Kuester Generating Station  
Negaunee, Michigan  
Permit to Install 35-17 and 40 CFR Part 63 Subpart ZZZZ  
EURICE1, EURICE2, EURICE3, EURICE4, EURICE5, EURICE6, and EURICE7  
Compliance Emissions Test Report Submittal**

Dear Mr. Scanlan:

Upper Michigan Energy Resources Corporation (UMERC) respectfully submits the results of reciprocating internal combustion engine (RICE) Maximum Achievable Control Technology (MACT) initial compliance testing conducted at the F.D. Kuester Generating Station units EURICE1, EURICE2, EURICE3, EURICE4, EURICE5, EURICE6, and EURICE7 during the period March 19-29, 2019.

The results demonstrate compliance with the conditions of Permit To Install 35-17 and 40 CFR Part 63 Subpart ZZZZ. A summary of results by emission unit is presented below.

Source	Pollutant	Test Result	RICE MACT Emission Limit
EURICE1	Formaldehyde	0.6 ppmvd @ 15% O2	14 ppmvd @ 15% O2
EURICE2	Formaldehyde	0.5 ppmvd @ 15% O2	14 ppmvd @ 15% O2
EURICE3	Formaldehyde	0.6 ppmvd @ 15% O2	14 ppmvd @ 15% O2
EURICE4	Formaldehyde	0.3 ppmvd @ 15% O2	14 ppmvd @ 15% O2
EURICE5	Formaldehyde	0.7 ppmvd @ 15% O2	14 ppmvd @ 15% O2
EURICE6	Formaldehyde	0.6 ppmvd @ 15% O2	14 ppmvd @ 15% O2
EURICE7	Formaldehyde	0.8 ppmvd @ 15% O2	14 ppmvd @ 15% O2

Enclosed please find the following Mostardi Platt test report:

- *Semiannual RICE MACT Compliance Emissions Test Report, Upper Michigan Resource Corporation, F.D. Kuester Generating Station, EURICE1, EURICE2, EURICE3, EURICE4, EURICE5, EURICE6, EURICE7, Negaunee, Michigan, Project No. M191105H, March 19 through March 29, 2019.*



If you have any questions or need additional information, please contact me at (414) 221-2389  
or [laura.jarmuz@wecenergygroup.com](mailto:laura.jarmuz@wecenergygroup.com).

Sincerely,



Laura Jarmuz  
Senior Engineer

cc: Karen Kajiya-Mills, Technical Programs Unit, EGLE, Air Quality Division  
Ed Nam, Director Air and Radiation, US EPA Region V  
Ed Lancaster, District Supervisor, EGLE, Air Quality Division—w/o enclosure  
Scott Johnson, UMER—electronic w/o enclosure  
Justin Kowalski, UMER—electronic w/o enclosure

Enclosure:

1. Mostardi Platt Project No. M191105H Report





**RECEIVED**

**MAY 06 2019**

**AIR QUALITY DIVISION**

## **Semiannual RICE MACT Compliance Emissions Test Report**

**Upper Michigan Resources Corporation  
F. D. Kuester Generating Station  
Permit No. 35-17  
EURICE1, EURICE2, EURICE3, EURICE4, EURICE5, EURICE6,  
EURICE7  
Negaunee, Michigan  
March 19 through March 29, 2019**

**Report Submittal Date  
April 29, 2019**

© Copyright 2019  
All rights reserved in  
Mostardi Platt

**Project No. M191105H**



---

## TABLE OF CONTENTS

1.0 EXECUTIVE SUMMARY .....	1
2.0 TEST METHODOLOGY .....	2
Method 3A Oxygen (O <sub>2</sub> )/Carbon Dioxide (CO <sub>2</sub> ) Determination .....	3
Method 320 Formaldehyde (HCHO) Determination .....	3
3.0 TEST RESULT SUMMARIES .....	6
4.0 CERTIFICATION.....	8
APPENDIX	
Appendix A – Plant Operating Data.....	11
Appendix B - Test Section Diagrams.....	28
Appendix C - Sample Train Diagrams .....	30
Appendix D - Calculation Nomenclature and Formulas .....	32
Appendix E - Reference Method Test Data (Computerized Sheets) .....	49
Appendix F - Calibration Data .....	92
Appendix G - Gas Cylinder Calibration Sheets .....	137





## 1.0 EXECUTIVE SUMMARY

MOSTARDI PLATT conducted a formaldehyde emissions test program for Upper Michigan Energy Resources Corporation (UMERC) on March 18 through March 29, 2019 at F.D. Kuester Generating Station on the Reciprocating Internal Combustion Engine (EURICE) 1, EURICE2, EURICE3, EURICE4, EURICE5, EURICE6, and EURICE7 Outlet Ducts in Negaunee, Michigan. The purpose of the test program was to meet the initial compliance demonstration requirements for emission rates in accordance with Permit to Install 35-17 and the RICE MACT 40 CFR Part 63 Subpart ZZZZ. This report summarizes the results of the test program and test methods used.

The test locations, test dates, and test parameters are summarized below.

TEST INFORMATION		
Test Locations	Test Dates	Test Parameters
EURICE1	March 19, 2019	Formaldehyde (CH <sub>2</sub> O), Moisture (H <sub>2</sub> O), and Oxygen (O <sub>2</sub> )
EURICE2	March 25, 2019	(CH <sub>2</sub> O), (H <sub>2</sub> O), and (O <sub>2</sub> )
EURICE3	March 20, 2019	(CH <sub>2</sub> O), (H <sub>2</sub> O), and (O <sub>2</sub> )
EURICE4	March 21, 2019	(CH <sub>2</sub> O), (H <sub>2</sub> O), and (O <sub>2</sub> )
EURICE5	March 27, 2019	(CH <sub>2</sub> O), (H <sub>2</sub> O), and (O <sub>2</sub> )
EURICE6	March 26, 2019	(CH <sub>2</sub> O), (H <sub>2</sub> O), and (O <sub>2</sub> )
EURICE7	March 28 and 29, 2019	(CH <sub>2</sub> O), (H <sub>2</sub> O), and (O <sub>2</sub> )

F. D. Kuester Generating Station electric generation facility includes seven (7) Wärtsilä W18V50SG natural gas-fired, four stroke, lean burn, spark ignition reciprocating internal combustion engines (RICE) coupled to 18,817 kW electric generators, a 1,000 kW natural gas-fired emergency generator, and one natural gas-fired natural gas conditioning heater. The RICE electric generating unit engines utilize pipeline quality natural gas and are equipped with selective catalytic reduction (SCR) for nitrogen oxides (NO<sub>x</sub>) control and oxidation catalyst systems for carbon monoxide (CO), volatile organic compound (VOC), and organic hazardous air pollutant (HAP) control. Each RICE electric generating unit exhausts into a common stack. Testing was done at the outlet duct to isolate the emissions from each unit.

Selected results of the test program are summarized below. A complete summary of emission test results follows the narrative portion of this report.



TEST RESULTS				
Test Location	Date	Test Parameter	Emission Limit	Emission Rate
EURICE1	3/19/2019	Formaldehyde	14 ppmvd @ 15% O <sub>2</sub>	0.6 ppmvd @ 15% O <sub>2</sub>
EURICE2	3/25/2019			0.5 ppmvd @ 15% O <sub>2</sub>
EURICE3	3/20/2019			0.6 ppmvd @ 15% O <sub>2</sub>
EURICE4	3/21/2019			0.3 ppmvd @ 15% O <sub>2</sub>
EURICE5	3/27/2019			0.7 ppmvd @ 15% O <sub>2</sub>
EURICE6	3/26/2019			0.6 ppmvd @ 15% O <sub>2</sub>
EURICE7	3/28-29/2019			0.8 ppmvd @ 15% O <sub>2</sub>

Operating Data as provided by the plant is included in Appendix A.

The identifications of the individuals associated with the test program are summarized below.

TEST PERSONNEL INFORMATION		
Location	Address	Contact
Test Coordinator	The University of Iowa Main Power Plant Iowa City, Iowa	Ms. Laura Jarmuz Senior Engineer 414-221-2389 <a href="mailto:Laura.jarmuz@wecenergygroup.com">Laura.jarmuz@wecenergygroup.com</a>
Test Facility	WEC Energy Group, Inc 231 W. Michigan Street Milwaukee, Wisconsin 53203	
Testing Company Representative	Mostardi Platt 888 Industrial Drive Elmhurst, Illinois 60126	Mr. John S Nestor Project Manager (630) 993-2100 (phone) <a href="mailto:jnestor@mp-mail.com">jnestor@mp-mail.com</a>

The test crew consisted Messrs. J. Nestor, M. Peterson, N. Colangelo, J. Gross, J. Carlson, K. Krofel and R. Sollars of Mostardi Platt.

## 2.0 TEST METHODOLOGY

Emission testing was conducted following the methods specified in 40CFR60, Appendix A and 40CFR63, Appendix A. Schematics of the test section diagrams and sampling trains used are included in Appendix B and C, respectively. Calculation nomenclature and example calculations are included in Appendix D. Reference method test data can be found in Appendix E.



The following methodology was used during the test program:

### Method 3A Oxygen (O<sub>2</sub>)

CO<sub>2</sub> and O<sub>2</sub> concentrations were measured to determine stack gas molecular weight and emission rates in ppmvd corrected to 15% O<sub>2</sub> in accordance with Method 3A. An ECOM analyzer was used to determine stack gas oxygen. All of the equipment used was calibrated in accordance with the specifications of the Method. Calibration data are presented in Appendix F and copies of gas cylinder certifications are included in Appendix G.

### Method 320 Formaldehyde (HCHO) and Moisture (H<sub>2</sub>O) Determination

FTIR data was collected using an MKS MultiGas 2030 FTIR spectrometer.

The FTIR was equipped with a temperature-controlled, 5.11 meter multi-pass gas cell maintained at 191°C. Gas flows and sampling system pressures were monitored using a rotameter and pressure transducer. All data was collected at 0.5 cm<sup>-1</sup> resolution. Each spectrum was derived from the coaddition of 62 scans, with a new data point generated approximately every one minute. Analyzer data for each run is present in Appendix E.

SAMPLING SYSTEM PARAMETERS				
MKS Serial #	Sampling Line	Probe Assembly	Particulate Filter Media	Operating Temperatures
019088128	100' 3/8" dia., heated Teflon	Heated 3', 3/8" dia. SS	0.01µ heated borosilicate glass fiber	191°C

QA/QC procedures followed US EPA Method 320. See below for QA/QC procedure details and list of calibration gas standards. All calibration gases were introduced to the analyzer and the sampling system using an instrument grade stainless steel rotameter. All QA/QC procedures were within the acceptance criteria allowance of the applicable EPA methodology. See Appendix F for FTIR QA/QC Data.

FTIR QA/QC PROCEDURES						
QA/QC Specification	Purpose	Calibration Gas Analyte	Delivery	Frequency	Acceptance Criteria	Result
M320: Zero	Verify that the FTIR is free of contaminants & zero the FTIR	Nitrogen (zero)	Direct to FTIR	pre/post test	< MDL or Noise	Pass
M320: Calibration Transfer Standard (CTS) Direct	Verify FTIR stability, confirm optical path length	Ethylene	Direct to FTIR	pretest	+/- 5% cert. value	Pass
M320: Analyte Direct	Verify FTIR calibration	Acetaldehyde, Methanol, SF <sub>6</sub>	Direct to FTIR	pretest	+/- 5% cert. value	Pass
M320: CTS Response	Verify system stability, recovery, response time	Ethylene	Sampling System	Daily, pre/post test	+/- 5% of Direct Measurement	Pass



FTIR QA/QC PROCEDURES						
QA/QC Specification	Purpose	Calibration Gas Analyte	Delivery	Frequency	Acceptance Criteria	Result
M320: Zero Response	Verify system is free of contaminants, system bias	Nitrogen (zero)	Sampling System	pretest	Bias correct data	Pass
M320: Analyte Spike	Verify system ability to deliver and quantify analyte of interest in the presence of other effluent gases	Acetaldehyde, Methanol, SF6	Dynamic Addition to Sampling System, 1:10 effluent	Throughout testing – daily	+/- 30% theoretical recovery	Pass

Note: The determined concentrations from direct analyses were used in all system/spike recovery calculations.

CALIBRATION GAS STANDARDS				
Components	Concentration (ppm)	Vendor	Cylinder #	Standard Type
Ethylene	100.0	Airgas	CC111625	Primary +/- 1%
Acetaldehyde/ Methanol/SF6	194.4/195.3/ 4.820	Airgas	CC475635	Certified Standard-Spec +/- 5%
Nitrogen	Zero Gas	Airgas	N/A	UHP Grade

### Analyte Spiking

Acetaldehyde and methanol spiking was performed prior to testing to verify the ability of the sampling system to quantitatively deliver a sample containing acetaldehyde and methanol from the base of the probe to the FTIR. Analyte spiking assures the ability of the FTIR sampling system to recover volatile organics in the presence of effluent gas.

As part of the spiking procedure, samples were measured to determine native acetaldehyde and methanol concentrations to be used in the spike recovery calculations. The analyte spiking gases contained a low concentration of sulfur hexafluoride (SF<sub>6</sub>). The determined SF<sub>6</sub> concentration in the spiked sample was used to calculate the dilution factor of the spike and thus used to calculate the concentration of the spiked Acetaldehyde and methanol. The spike target dilution ratio was 1:10 or less.

The following equation illustrates the percent recovery calculation.

$$DF = \frac{SF_6(sp)}{SF_6(dir)} \quad (\text{Sec. 9.2.3 (3) USEPA Method 320})$$

$$CS = DF * Spike(dir) + Unspike(1 - DF) \quad (\text{Sec. 9.2.3 (4) USEPA Method 320})$$

- DF = Dilution factor of the spike gas
- SF<sub>6(dir)</sub> = SF<sub>6</sub> concentration measured directly in undiluted spike gas
- SF<sub>6(sp)</sub> = Diluted SF<sub>6</sub> concentration measured in a spiked sample
- Spike<sub>dir</sub> = Concentration of the analyte in the spike standard measure by the FTIR directly
- CS = Expected concentration of the spiked samples
- Unspike = Native concentration of analytes in unspiked samples





### **Post Collection Data Validation**

As part of the data validation procedure, reference spectra are manually fit to that of the sample spectra and a concentration is determined. The reference spectra are scaled to match the peak amplitude of the sample, thus providing a scale factor. The scale factor multiplied by the reference spectra concentration is used to determine the concentration value for the sample spectra. Sample pressure and temperature corrections are then applied to compute the final sample concentration. The manually calculated results are then compared with the software-generated results. The data is then validated if the two concentrations are within  $\pm 20\%$  agreement. If there is a difference greater than  $\pm 20\%$  the spectra are reviewed for possible spectra interferences or any other possible causes leading to incorrectly quantified data.

### **Detection Limit**

The detection limit of each analyte was calculated following Annex A2 of ASTM D6348-12 procedure using spectra that contained similar amounts of moisture and carbon dioxide.

Analyte	Detection Limit (ppmv wet)	Detection Limit (%v)
Formaldehyde	0.2	-
Moisture	-	0.1

QA/QC data are found in Appendix F. Copies of gas cylinder certifications are found in Appendix G. All concentration data were recorded on a wet, volume basis. The sample and data collection followed the procedures outlined in Method 320.



### 3.0 TEST RESULT SUMMARIES

RICE MACT Compliance Emission Summary Upper Michigan Resource Generation Company F. D. Kuester Generating Station EURICE1 Outlet Duct						
Run Number	Date	Time	Formaldehyde (ppmv wet)	H2O (%)	O2 (%v Dry)	Formaldehyde (ppmv dry @ 15% O2)
1	3/19/2019	8:15-9:14	0.9	9.1	11.8	0.6
2	3/19/2019	11:15-12:14	0.9	9.0	11.8	0.6
3	3/19/2019	14:25-15:24	0.9	9.1	11.8	0.6
Average			0.9	9.1	11.8	0.6

RICE MACT Compliance Emission Summary Upper Michigan Resource Generation Company F. D. Kuester Generating Station EURICE2 Outlet Duct						
Run Number	Date	Time	Formaldehyde (ppmv wet)	H2O (%)	O2 (%v Dry)	Formaldehyde (ppmv dry @ 15% O2)
1	3/25/2019	9:00-9:59	0.7	9.1	12.1	0.5
2	3/25/2019	11:30-12:29	0.7	9.0	11.9	0.5
3	3/25/2019	13:55-14:54	0.8	9.0	12.0	0.6
Average			0.7	9.0	12.0	0.5

RICE MACT Compliance Emission Summary Upper Michigan Resource Generation Company F. D. Kuester Generating Station EURICE3 Outlet Duct						
Run Number	Date	Time	Formaldehyde (ppmv wet)	H2O (%)	O2 (%v Dry)	Formaldehyde (ppmv dry @ 15% O2)
1	3/20/2019	10:15-11:14	0.8	9.7	11.6	0.6
2	3/20/2019	13:00-13:59	0.8	9.6	11.5	0.6
3	3/20/2019	16:00-16:59	0.8	9.6	11.5	0.6
Average			0.8	9.6	11.5	0.6

RICE MACT Compliance Emission Summary Upper Michigan Resource Generation Company F. D. Kuester Generating Station EURICE4 Outlet Duct						
Run Number	Date	Time	Formaldehyde (ppmv wet)	H2O (%)	O2 (%v Dry)	Formaldehyde (ppmv dry @ 15% O2)
1	3/21/2019	8:53-9:52	0.4	9.8	11.2	0.3
2	3/21/2019	11:45-12:44	0.4	9.6	11.3	0.3
3	3/21/2019	14:35-15:34	0.4	9.6	11.4	0.3
Average			0.4	9.7	11.3	0.3



RICE MACT Compliance Emission Summary Upper Michigan Resource Generation Company F. D. Kuester Generating Station EURICE5 Outlet Duct						
Run Number	Date	Time	Formaldehyde (ppmv wet)	H2O (%v)	O2 (%v Dry)	Formaldehyde (ppmv dry @ 15% O2)
1	3/27/2019	8:15-9:14	1.0	9.2	11.9	0.7
2	3/27/2019	10:50-11:49	1.0	9.2	12.2	0.7
3	3/27/2019	13:20-14:19	0.9	9.3	12.1	0.7
Average			1.0	9.2	12.1	0.7

RICE MACT Compliance Emission Summary Upper Michigan Resource Generation Company F. D. Kuester Generating Station EURICE6 Outlet Duct						
Run Number	Date	Time	Formaldehyde (ppmv wet)	H2O (%v)	O2 (%v Dry)	Formaldehyde (ppmv dry @ 15% O2)
1	3/26/2019	8:30-9:29	0.8	9.0	11.9	0.6
2	3/26/2019	10:55-11:54	0.8	9.0	11.9	0.6
3	3/26/2019	13:25-14:49	0.8	9.0	11.9	0.6
Average			0.8	9.0	11.9	0.6

RICE MACT Compliance Emission Summary Upper Michigan Resource Generation Company F. D. Kuester Generating Station EURICE7 Outlet Duct						
Run Number	Date	Time	Formaldehyde (ppmv wet)	H2O (%v)	O2 (%v Dry)	Formaldehyde (ppmv dry @ 15% O2)
1	3/28/2019	8:15-9:14	1.1	9.4	11.9	0.8
2	3/28/2019	10:35-11:34	1.1	9.3	12.0	0.8
3	3/29/2019	7:54-8:53	1.1	9.2	11.9	0.8
Average			1.1	9.3	11.9	0.8



## 4.0 CERTIFICATION

MOSTARDI PLATT is pleased to have been of service to Upper Michigan Energy Resources Corporation. If you have any questions regarding this test report, please do not hesitate to contact us at 630-993-2100.

### CERTIFICATION

As project manager, I hereby certify that this test report represents a true and accurate summary of emissions test results and the methodologies employed to obtain those results, and the test program was performed in accordance with the methods specified in this test report.

MOSTARDI PLATT



Project Manager

John S. Nestor



Quality Assurance

Scott W. Banach





---

# APPENDICES



## Appendix A – Plant Operating Data

**F.D. Kuester Generating Station  
RICE MACT Compliance Emissions Testing  
Summary of Operating Data**

<b>EURICE1</b>				
3/19/2019				
Method 3A and 320				
Start Time	815	1115	1425	
End Time	914	1214	1524	
	Run 1	Run 2	Run 3	Average
Engine (kW)	18,881	18,887	18,882	18,883
Engine natural gas use (pound/hour)	6,606	6,614	6,621	6,613
SCR/Oxidation catalyst inlet temperature) (deg F)	703	702	699	701
Pressure drop across the oxidation catalyst (PSI)	0.14	0.13	0.13	0.13

<b>EURICE2</b>				
Method 3A and 320				
Start Time	900	1130	1355	
End Time	959	1229	1454	
	Run 1	Run 2	Run 3	Average
Engine (kW)	18,848	18,852	18,843	18,848
Engine natural gas use (pound/hour)	6,499	6,554	6,571	6,541
SCR/Oxidation catalyst inlet temperature) (deg F)	701	699	698	699
Pressure drop across the oxidation catalyst (PSI)	0.18	0.18	0.19	0.19

<b>EURICE3</b>				
Method 3A and 320				
Start Time	1015	1300	1600	
End Time	1114	1359	1659	
	Run 1	Run 2	Run 3	Average
Engine (kW)	18,861	18,865	18,859	18,862
Engine natural gas use (pound/hour)	6,589	6,542	6,543	6,559
SCR/Oxidation catalyst inlet temperature) (deg F)	708	709	710	709
Pressure drop across the oxidation catalyst (PSI)	0.14	0.14	0.14	0.14

<b>EURICE4</b>				
3/21/2019				
Method 3A and 320				
Start Time	853	1145	1435	
End Time	952	1244	1534	
	Run 1	Run 2	Run 3	Average
Engine (kW)	18,861	18,858	18,862	18,860
Engine natural gas use (pound/hour)	6,401	6,429	6,492	6,441
SCR/Oxidation catalyst inlet temperature) (deg F)	712	711	708	710
Pressure drop across the oxidation catalyst (PSI)	0.15	0.15	0.19	0.16

<b>EURICE5</b>				
3/27/2019				
Method 3A and 320				
Start Time	815	1050	1320	
End Time	914	1149	1419	
	Run 1	Run 2	Run 3	Average
Engine (kW)	18,867	18,871	18,878	18,872
Engine natural gas use (pound/hour)	6,618	6,611	6,535	6,588
SCR/Oxidation catalyst inlet temperature) (deg F)	695	695	697	696
Pressure drop across the oxidation catalyst (PSI)	0.12	0.12	0.12	0.12

<b>EURICE6</b>				
3/26/2019				
Method 3A and 320				
Start Time	830	1055	1325	
End Time	929	1154	1449	
	Run 1	Run 2	Run 3	Average
Engine (kW)	18,901	18,901	18,897	18,900
Engine natural gas use (pound/hour)	6,646	6,636	6,654	6,646
SCR/Oxidation catalyst inlet temperature) (deg F)	697	696	694	696
Pressure drop across the oxidation catalyst (PSI)	0.16	0.13	0.13	0.14

<b>EURICE7</b>				
3/28 and 3/29/2019				
Method 3A and 320				
Start Time	3/28/2019	3/28/2019	3/29/2019	
End Time	814	1035	755	
	914	1134	854	
	Run 1	Run 2	Run 3	Average
Engine (kW)	18,870	18,875	18,118	18,621
Engine natural gas use (pound/hour)	6,466	6,299	6,292	6,352
SCR/Oxidation catalyst inlet temperature) (deg F)	698	696	697	697
Pressure drop across the oxidation catalyst (PSI)	0.10	0.10	0.10	0.10

**Upper Michigan Energy Resources Corporation  
Mihm Generating Station  
Temperature and Pressure Data**

<b>Unit</b>	<b>Date</b>	<b>Barometric Pressure, Inches Hg</b>	<b>Ambient Temperature, ° F</b>	<b>Relative Humidity, %</b>
EURICE1	03/19/19	29.13	30	68.82
EURICE2	03/25/19	29.23	22	62.10
EURICE3	03/20/19	28.78	36	75.47
EURICE4	03/21/19	28.88	41	64.65
EURICE5	03/27/19	29.06	36	66.71
EURICE6	03/26/19	29.28	25	57.25
EURICE7	03/28/19	28.83	36	75.47
EURICE7	03/29/19	29.06	30	63.20

EURICE1  
SCR/Oxidation Catalyst Inlet Temperature

Start Time	End Time	Value/Average (Deg F)
03-19-2019 08:15 EDT	03-19-2019 08:20 EDT	702
03-19-2019 08:20 EDT	03-19-2019 08:25 EDT	702
03-19-2019 08:25 EDT	03-19-2019 08:30 EDT	703
03-19-2019 08:30 EDT	03-19-2019 08:35 EDT	703
03-19-2019 08:35 EDT	03-19-2019 08:40 EDT	703
03-19-2019 08:40 EDT	03-19-2019 08:45 EDT	703
03-19-2019 08:45 EDT	03-19-2019 08:50 EDT	703
03-19-2019 08:50 EDT	03-19-2019 08:55 EDT	703
03-19-2019 08:55 EDT	03-19-2019 09:00 EDT	703
03-19-2019 09:00 EDT	03-19-2019 09:05 EDT	703
03-19-2019 09:05 EDT	03-19-2019 09:10 EDT	703
03-19-2019 09:10 EDT	03-19-2019 09:15 EDT	702
03-19-2019 09:15 EDT	03-19-2019 09:20 EDT	703
03-19-2019 09:20 EDT	03-19-2019 09:25 EDT	702
03-19-2019 09:25 EDT	03-19-2019 09:30 EDT	703
03-19-2019 09:30 EDT	03-19-2019 09:35 EDT	703
03-19-2019 09:35 EDT	03-19-2019 09:40 EDT	703
03-19-2019 09:40 EDT	03-19-2019 09:45 EDT	702
03-19-2019 09:45 EDT	03-19-2019 09:50 EDT	702
03-19-2019 09:50 EDT	03-19-2019 09:55 EDT	702
03-19-2019 09:55 EDT	03-19-2019 10:00 EDT	703
03-19-2019 10:00 EDT	03-19-2019 10:05 EDT	702
03-19-2019 10:05 EDT	03-19-2019 10:10 EDT	702
03-19-2019 10:10 EDT	03-19-2019 10:15 EDT	702
03-19-2019 10:15 EDT	03-19-2019 10:20 EDT	702
03-19-2019 10:20 EDT	03-19-2019 10:25 EDT	702
03-19-2019 10:25 EDT	03-19-2019 10:30 EDT	702
03-19-2019 10:30 EDT	03-19-2019 10:35 EDT	702
03-19-2019 10:35 EDT	03-19-2019 10:40 EDT	702
03-19-2019 10:40 EDT	03-19-2019 10:45 EDT	702
03-19-2019 10:45 EDT	03-19-2019 10:50 EDT	702
03-19-2019 10:50 EDT	03-19-2019 10:55 EDT	702
03-19-2019 10:55 EDT	03-19-2019 11:00 EDT	702
03-19-2019 11:00 EDT	03-19-2019 11:05 EDT	703
03-19-2019 11:05 EDT	03-19-2019 11:10 EDT	702
03-19-2019 11:10 EDT	03-19-2019 11:15 EDT	702
03-19-2019 11:15 EDT	03-19-2019 11:20 EDT	702
03-19-2019 11:20 EDT	03-19-2019 11:25 EDT	702
03-19-2019 11:25 EDT	03-19-2019 11:30 EDT	702
03-19-2019 11:30 EDT	03-19-2019 11:35 EDT	702
03-19-2019 11:35 EDT	03-19-2019 11:40 EDT	702
03-19-2019 11:40 EDT	03-19-2019 11:45 EDT	702
03-19-2019 11:45 EDT	03-19-2019 11:50 EDT	702
03-19-2019 11:50 EDT	03-19-2019 11:55 EDT	702
03-19-2019 11:55 EDT	03-19-2019 12:00 EDT	702
03-19-2019 12:00 EDT	03-19-2019 12:05 EDT	702
03-19-2019 12:05 EDT	03-19-2019 12:10 EDT	702
03-19-2019 12:10 EDT	03-19-2019 12:15 EDT	702

03-19-2019 12:15 EDT	03-19-2019 12:20 EDT	702
03-19-2019 12:20 EDT	03-19-2019 12:25 EDT	703
03-19-2019 12:25 EDT	03-19-2019 12:30 EDT	702
03-19-2019 12:30 EDT	03-19-2019 12:35 EDT	703
03-19-2019 12:35 EDT	03-19-2019 12:40 EDT	703
03-19-2019 12:40 EDT	03-19-2019 12:45 EDT	703
03-19-2019 12:45 EDT	03-19-2019 12:50 EDT	702
03-19-2019 12:50 EDT	03-19-2019 12:55 EDT	702
03-19-2019 12:55 EDT	03-19-2019 13:00 EDT	702
03-19-2019 13:00 EDT	03-19-2019 13:05 EDT	702
03-19-2019 13:05 EDT	03-19-2019 13:10 EDT	702
03-19-2019 13:10 EDT	03-19-2019 13:15 EDT	702
03-19-2019 13:15 EDT	03-19-2019 13:20 EDT	702
03-19-2019 13:20 EDT	03-19-2019 13:25 EDT	702
03-19-2019 13:25 EDT	03-19-2019 13:30 EDT	701
03-19-2019 13:30 EDT	03-19-2019 13:35 EDT	701
03-19-2019 13:35 EDT	03-19-2019 13:40 EDT	700
03-19-2019 13:40 EDT	03-19-2019 13:45 EDT	700
03-19-2019 13:45 EDT	03-19-2019 13:50 EDT	702
03-19-2019 13:50 EDT	03-19-2019 13:55 EDT	700
03-19-2019 13:55 EDT	03-19-2019 14:00 EDT	700
03-19-2019 14:00 EDT	03-19-2019 14:05 EDT	700
03-19-2019 14:05 EDT	03-19-2019 14:10 EDT	700
03-19-2019 14:10 EDT	03-19-2019 14:15 EDT	700
03-19-2019 14:15 EDT	03-19-2019 14:20 EDT	700
03-19-2019 14:20 EDT	03-19-2019 14:25 EDT	700
03-19-2019 14:25 EDT	03-19-2019 14:30 EDT	700
03-19-2019 14:30 EDT	03-19-2019 14:35 EDT	699
03-19-2019 14:35 EDT	03-19-2019 14:40 EDT	699
03-19-2019 14:40 EDT	03-19-2019 14:45 EDT	700
03-19-2019 14:45 EDT	03-19-2019 14:50 EDT	699
03-19-2019 14:50 EDT	03-19-2019 14:55 EDT	699
03-19-2019 14:55 EDT	03-19-2019 15:00 EDT	700
03-19-2019 15:00 EDT	03-19-2019 15:05 EDT	699
03-19-2019 15:05 EDT	03-19-2019 15:10 EDT	698
03-19-2019 15:10 EDT	03-19-2019 15:15 EDT	698
03-19-2019 15:15 EDT	03-19-2019 15:20 EDT	698
03-19-2019 15:20 EDT	03-19-2019 15:25 EDT	698
03-19-2019 15:25 EDT	03-19-2019 15:30 EDT	698
03-19-2019 15:30 EDT	03-19-2019 15:35 EDT	698
03-19-2019 15:35 EDT	03-19-2019 15:40 EDT	698
03-19-2019 15:40 EDT	03-19-2019 15:45 EDT	698
03-19-2019 15:45 EDT	03-19-2019 15:50 EDT	698
03-19-2019 15:50 EDT	03-19-2019 15:55 EDT	698
03-19-2019 15:55 EDT	03-19-2019 16:00 EDT	698
03-19-2019 16:00 EDT	03-19-2019 16:05 EDT	698
03-19-2019 16:05 EDT	03-19-2019 16:10 EDT	700
03-19-2019 16:10 EDT	03-19-2019 16:15 EDT	699
03-19-2019 16:15 EDT	03-19-2019 16:20 EDT	698
03-19-2019 16:20 EDT	03-19-2019 16:25 EDT	698
03-19-2019 16:25 EDT	03-19-2019 16:30 EDT	699

EURICE2  
SCR/Oxidation Catalyst Inlet Temperature

Start Time	End Time	Value/Average (Deg F)
03-25-2019 09:00 EDT	03-25-2019 09:05 EDT	702
03-25-2019 09:05 EDT	03-25-2019 09:10 EDT	702
03-25-2019 09:10 EDT	03-25-2019 09:15 EDT	702
03-25-2019 09:15 EDT	03-25-2019 09:20 EDT	702
03-25-2019 09:20 EDT	03-25-2019 09:25 EDT	702
03-25-2019 09:25 EDT	03-25-2019 09:30 EDT	702
03-25-2019 09:30 EDT	03-25-2019 09:35 EDT	702
03-25-2019 09:35 EDT	03-25-2019 09:40 EDT	702
03-25-2019 09:40 EDT	03-25-2019 09:45 EDT	702
03-25-2019 09:45 EDT	03-25-2019 09:50 EDT	702
03-25-2019 09:50 EDT	03-25-2019 09:55 EDT	702
03-25-2019 09:55 EDT	03-25-2019 10:00 EDT	702
03-25-2019 10:00 EDT	03-25-2019 10:05 EDT	702
03-25-2019 10:05 EDT	03-25-2019 10:10 EDT	701
03-25-2019 10:10 EDT	03-25-2019 10:15 EDT	702
03-25-2019 10:15 EDT	03-25-2019 10:20 EDT	700
03-25-2019 10:20 EDT	03-25-2019 10:25 EDT	700
03-25-2019 10:25 EDT	03-25-2019 10:30 EDT	700
03-25-2019 10:30 EDT	03-25-2019 10:35 EDT	700
03-25-2019 10:35 EDT	03-25-2019 10:40 EDT	700
03-25-2019 10:40 EDT	03-25-2019 10:45 EDT	700
03-25-2019 10:45 EDT	03-25-2019 10:50 EDT	700
03-25-2019 10:50 EDT	03-25-2019 10:55 EDT	700
03-25-2019 10:55 EDT	03-25-2019 11:00 EDT	700
03-25-2019 11:00 EDT	03-25-2019 11:05 EDT	700
03-25-2019 11:05 EDT	03-25-2019 11:10 EDT	700
03-25-2019 11:10 EDT	03-25-2019 11:15 EDT	700
03-25-2019 11:15 EDT	03-25-2019 11:20 EDT	700
03-25-2019 11:20 EDT	03-25-2019 11:25 EDT	700
03-25-2019 11:25 EDT	03-25-2019 11:30 EDT	700
03-25-2019 11:30 EDT	03-25-2019 11:35 EDT	700
03-25-2019 11:35 EDT	03-25-2019 11:40 EDT	701
03-25-2019 11:40 EDT	03-25-2019 11:45 EDT	700
03-25-2019 11:45 EDT	03-25-2019 11:50 EDT	700
03-25-2019 11:50 EDT	03-25-2019 11:55 EDT	700
03-25-2019 11:55 EDT	03-25-2019 12:00 EDT	700
03-25-2019 12:00 EDT	03-25-2019 12:05 EDT	700
03-25-2019 12:05 EDT	03-25-2019 12:10 EDT	699
03-25-2019 12:10 EDT	03-25-2019 12:15 EDT	699
03-25-2019 12:15 EDT	03-25-2019 12:20 EDT	700
03-25-2019 12:20 EDT	03-25-2019 12:25 EDT	699
03-25-2019 12:25 EDT	03-25-2019 12:30 EDT	699
03-25-2019 12:30 EDT	03-25-2019 12:35 EDT	699
03-25-2019 12:35 EDT	03-25-2019 12:40 EDT	698
03-25-2019 12:40 EDT	03-25-2019 12:45 EDT	698
03-25-2019 12:45 EDT	03-25-2019 12:50 EDT	698



03-25-2019 12:50 EDT	03-25-2019 12:55 EDT	698
03-25-2019 12:55 EDT	03-25-2019 13:00 EDT	698
03-25-2019 13:00 EDT	03-25-2019 13:05 EDT	698
03-25-2019 13:05 EDT	03-25-2019 13:10 EDT	698
03-25-2019 13:10 EDT	03-25-2019 13:15 EDT	698
03-25-2019 13:15 EDT	03-25-2019 13:20 EDT	698
03-25-2019 13:20 EDT	03-25-2019 13:25 EDT	698
03-25-2019 13:25 EDT	03-25-2019 13:30 EDT	697
03-25-2019 13:30 EDT	03-25-2019 13:35 EDT	698
03-25-2019 13:35 EDT	03-25-2019 13:40 EDT	698
03-25-2019 13:40 EDT	03-25-2019 13:45 EDT	698
03-25-2019 13:45 EDT	03-25-2019 13:50 EDT	698
03-25-2019 13:50 EDT	03-25-2019 13:55 EDT	698
03-25-2019 13:55 EDT	03-25-2019 14:00 EDT	698
03-25-2019 14:00 EDT	03-25-2019 14:05 EDT	698
03-25-2019 14:05 EDT	03-25-2019 14:10 EDT	698
03-25-2019 14:10 EDT	03-25-2019 14:15 EDT	698
03-25-2019 14:15 EDT	03-25-2019 14:20 EDT	698
03-25-2019 14:20 EDT	03-25-2019 14:25 EDT	698
03-25-2019 14:25 EDT	03-25-2019 14:30 EDT	698
03-25-2019 14:30 EDT	03-25-2019 14:35 EDT	698
03-25-2019 14:35 EDT	03-25-2019 14:40 EDT	698
03-25-2019 14:40 EDT	03-25-2019 14:45 EDT	698
03-25-2019 14:45 EDT	03-25-2019 14:50 EDT	697
03-25-2019 14:50 EDT	03-25-2019 14:55 EDT	696
03-25-2019 14:55 EDT	03-25-2019 15:00 EDT	696
03-25-2019 15:00 EDT	03-25-2019 15:05 EDT	696
03-25-2019 15:05 EDT	03-25-2019 15:10 EDT	697
03-25-2019 15:10 EDT	03-25-2019 15:15 EDT	696
03-25-2019 15:15 EDT	03-25-2019 15:20 EDT	698
03-25-2019 15:20 EDT	03-25-2019 15:25 EDT	698
03-25-2019 15:25 EDT	03-25-2019 15:30 EDT	698
03-25-2019 15:30 EDT	03-25-2019 15:35 EDT	698
03-25-2019 15:35 EDT	03-25-2019 15:40 EDT	698
03-25-2019 15:40 EDT	03-25-2019 15:45 EDT	698
03-25-2019 15:45 EDT	03-25-2019 15:50 EDT	698
03-25-2019 15:50 EDT	03-25-2019 15:55 EDT	698
03-25-2019 15:55 EDT	03-25-2019 16:00 EDT	698

EURICE3  
SCR/Oxidation Catalyst Inlet Temperature

Start Time	End Time	Value/Average (Deg F)
03-20-2019 09:30 EDT	03-20-2019 09:35 EDT	707
03-20-2019 09:35 EDT	03-20-2019 09:40 EDT	707
03-20-2019 09:40 EDT	03-20-2019 09:45 EDT	707
03-20-2019 09:45 EDT	03-20-2019 09:50 EDT	707
03-20-2019 09:50 EDT	03-20-2019 09:55 EDT	707
03-20-2019 09:55 EDT	03-20-2019 10:00 EDT	707
03-20-2019 10:00 EDT	03-20-2019 10:05 EDT	707
03-20-2019 10:05 EDT	03-20-2019 10:10 EDT	707
03-20-2019 10:10 EDT	03-20-2019 10:15 EDT	707
03-20-2019 10:15 EDT	03-20-2019 10:20 EDT	707
03-20-2019 10:20 EDT	03-20-2019 10:25 EDT	707
03-20-2019 10:25 EDT	03-20-2019 10:30 EDT	707
03-20-2019 10:30 EDT	03-20-2019 10:35 EDT	707
03-20-2019 10:35 EDT	03-20-2019 10:40 EDT	707
03-20-2019 10:40 EDT	03-20-2019 10:45 EDT	708
03-20-2019 10:45 EDT	03-20-2019 10:50 EDT	709
03-20-2019 10:50 EDT	03-20-2019 10:55 EDT	708
03-20-2019 10:55 EDT	03-20-2019 11:00 EDT	708
03-20-2019 11:00 EDT	03-20-2019 11:05 EDT	708
03-20-2019 11:05 EDT	03-20-2019 11:10 EDT	709
03-20-2019 11:10 EDT	03-20-2019 11:15 EDT	709
03-20-2019 11:15 EDT	03-20-2019 11:20 EDT	709
03-20-2019 11:20 EDT	03-20-2019 11:25 EDT	709
03-20-2019 11:25 EDT	03-20-2019 11:30 EDT	710
03-20-2019 11:30 EDT	03-20-2019 11:35 EDT	710
03-20-2019 11:35 EDT	03-20-2019 11:40 EDT	710
03-20-2019 11:40 EDT	03-20-2019 11:45 EDT	710
03-20-2019 11:45 EDT	03-20-2019 11:50 EDT	709
03-20-2019 11:50 EDT	03-20-2019 11:55 EDT	709
03-20-2019 11:55 EDT	03-20-2019 12:00 EDT	709
03-20-2019 12:00 EDT	03-20-2019 12:05 EDT	709
03-20-2019 12:05 EDT	03-20-2019 12:10 EDT	708
03-20-2019 12:10 EDT	03-20-2019 12:15 EDT	707
03-20-2019 12:15 EDT	03-20-2019 12:20 EDT	707
03-20-2019 12:20 EDT	03-20-2019 12:25 EDT	707
03-20-2019 12:25 EDT	03-20-2019 12:30 EDT	707
03-20-2019 12:30 EDT	03-20-2019 12:35 EDT	707
03-20-2019 12:35 EDT	03-20-2019 12:40 EDT	707
03-20-2019 12:40 EDT	03-20-2019 12:45 EDT	707
03-20-2019 12:45 EDT	03-20-2019 12:50 EDT	707
03-20-2019 12:50 EDT	03-20-2019 12:55 EDT	707
03-20-2019 12:55 EDT	03-20-2019 13:00 EDT	707
03-20-2019 13:00 EDT	03-20-2019 13:05 EDT	707
03-20-2019 13:05 EDT	03-20-2019 13:10 EDT	707
03-20-2019 13:10 EDT	03-20-2019 13:15 EDT	707
03-20-2019 13:15 EDT	03-20-2019 13:20 EDT	707
03-20-2019 13:20 EDT	03-20-2019 13:25 EDT	709
03-20-2019 13:25 EDT	03-20-2019 13:30 EDT	709
03-20-2019 13:30 EDT	03-20-2019 13:35 EDT	709
03-20-2019 13:35 EDT	03-20-2019 13:40 EDT	709

03-20-2019 13:40 EDT	03-20-2019 13:45 EDT	709
03-20-2019 13:45 EDT	03-20-2019 13:50 EDT	709
03-20-2019 13:50 EDT	03-20-2019 13:55 EDT	709
03-20-2019 13:55 EDT	03-20-2019 14:00 EDT	709
03-20-2019 14:00 EDT	03-20-2019 14:05 EDT	709
03-20-2019 14:05 EDT	03-20-2019 14:10 EDT	709
03-20-2019 14:10 EDT	03-20-2019 14:15 EDT	709
03-20-2019 14:15 EDT	03-20-2019 14:20 EDT	709
03-20-2019 14:20 EDT	03-20-2019 14:25 EDT	709
03-20-2019 14:25 EDT	03-20-2019 14:30 EDT	709
03-20-2019 14:30 EDT	03-20-2019 14:35 EDT	709
03-20-2019 14:35 EDT	03-20-2019 14:40 EDT	709
03-20-2019 14:40 EDT	03-20-2019 14:45 EDT	709
03-20-2019 14:45 EDT	03-20-2019 14:50 EDT	709
03-20-2019 14:50 EDT	03-20-2019 14:55 EDT	709
03-20-2019 14:55 EDT	03-20-2019 15:00 EDT	709
03-20-2019 15:00 EDT	03-20-2019 15:05 EDT	709
03-20-2019 15:05 EDT	03-20-2019 15:10 EDT	709
03-20-2019 15:10 EDT	03-20-2019 15:15 EDT	709
03-20-2019 15:15 EDT	03-20-2019 15:20 EDT	709
03-20-2019 15:20 EDT	03-20-2019 15:25 EDT	711
03-20-2019 15:25 EDT	03-20-2019 15:30 EDT	711
03-20-2019 15:30 EDT	03-20-2019 15:35 EDT	711
03-20-2019 15:35 EDT	03-20-2019 15:40 EDT	711
03-20-2019 15:40 EDT	03-20-2019 15:45 EDT	711
03-20-2019 15:45 EDT	03-20-2019 15:50 EDT	710
03-20-2019 15:50 EDT	03-20-2019 15:55 EDT	711
03-20-2019 15:55 EDT	03-20-2019 16:00 EDT	711
03-20-2019 16:00 EDT	03-20-2019 16:05 EDT	711
03-20-2019 16:05 EDT	03-20-2019 16:10 EDT	709
03-20-2019 16:10 EDT	03-20-2019 16:15 EDT	709
03-20-2019 16:15 EDT	03-20-2019 16:20 EDT	709
03-20-2019 16:20 EDT	03-20-2019 16:25 EDT	710
03-20-2019 16:25 EDT	03-20-2019 16:30 EDT	709
03-20-2019 16:30 EDT	03-20-2019 16:35 EDT	711
03-20-2019 16:35 EDT	03-20-2019 16:40 EDT	709
03-20-2019 16:40 EDT	03-20-2019 16:45 EDT	709
03-20-2019 16:45 EDT	03-20-2019 16:50 EDT	710
03-20-2019 16:50 EDT	03-20-2019 16:55 EDT	709
03-20-2019 16:55 EDT	03-20-2019 17:00 EDT	710
03-20-2019 17:00 EDT	03-20-2019 17:05 EDT	710
03-20-2019 17:05 EDT	03-20-2019 17:10 EDT	711
03-20-2019 17:10 EDT	03-20-2019 17:15 EDT	711
03-20-2019 17:15 EDT	03-20-2019 17:20 EDT	709
03-20-2019 17:20 EDT	03-20-2019 17:25 EDT	709
03-20-2019 17:25 EDT	03-20-2019 17:30 EDT	709
03-20-2019 17:30 EDT	03-20-2019 17:35 EDT	710
03-20-2019 17:35 EDT	03-20-2019 17:40 EDT	709
03-20-2019 17:40 EDT	03-20-2019 17:45 EDT	709
03-20-2019 17:45 EDT	03-20-2019 17:50 EDT	710
03-20-2019 17:50 EDT	03-20-2019 17:55 EDT	711
03-20-2019 17:55 EDT	03-20-2019 18:00 EDT	710
03-20-2019 18:00 EDT	03-20-2019 18:05 EDT	710

EURICE4  
SCR/Oxidation Catalyst Inlet Temperature

Start Time	End Time	Value/Average (Deg F)
03-21-2019 08:50 EDT	03-21-2019 08:55 EDT	713
03-21-2019 08:55 EDT	03-21-2019 09:00 EDT	713
03-21-2019 09:00 EDT	03-21-2019 09:05 EDT	712
03-21-2019 09:05 EDT	03-21-2019 09:10 EDT	712
03-21-2019 09:10 EDT	03-21-2019 09:15 EDT	712
03-21-2019 09:15 EDT	03-21-2019 09:20 EDT	712
03-21-2019 09:20 EDT	03-21-2019 09:25 EDT	712
03-21-2019 09:25 EDT	03-21-2019 09:30 EDT	712
03-21-2019 09:30 EDT	03-21-2019 09:35 EDT	712
03-21-2019 09:35 EDT	03-21-2019 09:40 EDT	712
03-21-2019 09:40 EDT	03-21-2019 09:45 EDT	712
03-21-2019 09:45 EDT	03-21-2019 09:50 EDT	712
03-21-2019 09:50 EDT	03-21-2019 09:55 EDT	712
03-21-2019 09:55 EDT	03-21-2019 10:00 EDT	712
03-21-2019 10:00 EDT	03-21-2019 10:05 EDT	712
03-21-2019 10:05 EDT	03-21-2019 10:10 EDT	712
03-21-2019 10:10 EDT	03-21-2019 10:15 EDT	712
03-21-2019 10:15 EDT	03-21-2019 10:20 EDT	712
03-21-2019 10:20 EDT	03-21-2019 10:25 EDT	712
03-21-2019 10:25 EDT	03-21-2019 10:30 EDT	712
03-21-2019 10:30 EDT	03-21-2019 10:35 EDT	712
03-21-2019 10:35 EDT	03-21-2019 10:40 EDT	712
03-21-2019 10:40 EDT	03-21-2019 10:45 EDT	712
03-21-2019 10:45 EDT	03-21-2019 10:50 EDT	712
03-21-2019 10:50 EDT	03-21-2019 10:55 EDT	712
03-21-2019 10:55 EDT	03-21-2019 11:00 EDT	713
03-21-2019 11:00 EDT	03-21-2019 11:05 EDT	712
03-21-2019 11:05 EDT	03-21-2019 11:10 EDT	713
03-21-2019 11:10 EDT	03-21-2019 11:15 EDT	712
03-21-2019 11:15 EDT	03-21-2019 11:20 EDT	712
03-21-2019 11:20 EDT	03-21-2019 11:25 EDT	713
03-21-2019 11:25 EDT	03-21-2019 11:30 EDT	713
03-21-2019 11:30 EDT	03-21-2019 11:35 EDT	713
03-21-2019 11:35 EDT	03-21-2019 11:40 EDT	713
03-21-2019 11:40 EDT	03-21-2019 11:45 EDT	712
03-21-2019 11:45 EDT	03-21-2019 11:50 EDT	712
03-21-2019 11:50 EDT	03-21-2019 11:55 EDT	712
03-21-2019 11:55 EDT	03-21-2019 12:00 EDT	712
03-21-2019 12:00 EDT	03-21-2019 12:05 EDT	712
03-21-2019 12:05 EDT	03-21-2019 12:10 EDT	711
03-21-2019 12:10 EDT	03-21-2019 12:15 EDT	711
03-21-2019 12:15 EDT	03-21-2019 12:20 EDT	711
03-21-2019 12:20 EDT	03-21-2019 12:25 EDT	711
03-21-2019 12:25 EDT	03-21-2019 12:30 EDT	711
03-21-2019 12:30 EDT	03-21-2019 12:35 EDT	711
03-21-2019 12:35 EDT	03-21-2019 12:40 EDT	711

03-21-2019 12:40 EDT	03-21-2019 12:45 EDT	711
03-21-2019 12:45 EDT	03-21-2019 12:50 EDT	711
03-21-2019 12:50 EDT	03-21-2019 12:55 EDT	711
03-21-2019 12:55 EDT	03-21-2019 13:00 EDT	711
03-21-2019 13:00 EDT	03-21-2019 13:05 EDT	711
03-21-2019 13:05 EDT	03-21-2019 13:10 EDT	711
03-21-2019 13:10 EDT	03-21-2019 13:15 EDT	711
03-21-2019 13:15 EDT	03-21-2019 13:20 EDT	711
03-21-2019 13:20 EDT	03-21-2019 13:25 EDT	711
03-21-2019 13:25 EDT	03-21-2019 13:30 EDT	711
03-21-2019 13:30 EDT	03-21-2019 13:35 EDT	711
03-21-2019 13:35 EDT	03-21-2019 13:40 EDT	711
03-21-2019 13:40 EDT	03-21-2019 13:45 EDT	711
03-21-2019 13:45 EDT	03-21-2019 13:50 EDT	711
03-21-2019 13:50 EDT	03-21-2019 13:55 EDT	711
03-21-2019 13:55 EDT	03-21-2019 14:00 EDT	711
03-21-2019 14:00 EDT	03-21-2019 14:05 EDT	711
03-21-2019 14:05 EDT	03-21-2019 14:10 EDT	711
03-21-2019 14:10 EDT	03-21-2019 14:15 EDT	711
03-21-2019 14:15 EDT	03-21-2019 14:20 EDT	711
03-21-2019 14:20 EDT	03-21-2019 14:25 EDT	711
03-21-2019 14:25 EDT	03-21-2019 14:30 EDT	710
03-21-2019 14:30 EDT	03-21-2019 14:35 EDT	710
03-21-2019 14:35 EDT	03-21-2019 14:40 EDT	709
03-21-2019 14:40 EDT	03-21-2019 14:45 EDT	709
03-21-2019 14:45 EDT	03-21-2019 14:50 EDT	709
03-21-2019 14:50 EDT	03-21-2019 14:55 EDT	709
03-21-2019 14:55 EDT	03-21-2019 15:00 EDT	709
03-21-2019 15:00 EDT	03-21-2019 15:05 EDT	709
03-21-2019 15:05 EDT	03-21-2019 15:10 EDT	709
03-21-2019 15:10 EDT	03-21-2019 15:15 EDT	707
03-21-2019 15:15 EDT	03-21-2019 15:20 EDT	707
03-21-2019 15:20 EDT	03-21-2019 15:25 EDT	707
03-21-2019 15:25 EDT	03-21-2019 15:30 EDT	707
03-21-2019 15:30 EDT	03-21-2019 15:35 EDT	707
03-21-2019 15:35 EDT	03-21-2019 15:40 EDT	707
03-21-2019 15:40 EDT	03-21-2019 15:45 EDT	707
03-21-2019 15:45 EDT	03-21-2019 15:50 EDT	707
03-21-2019 15:50 EDT	03-21-2019 15:55 EDT	707
03-21-2019 15:55 EDT	03-21-2019 16:00 EDT	707
03-21-2019 16:00 EDT	03-21-2019 16:05 EDT	707
03-21-2019 16:05 EDT	03-21-2019 16:10 EDT	707
03-21-2019 16:10 EDT	03-21-2019 16:15 EDT	710
03-21-2019 16:15 EDT	03-21-2019 16:20 EDT	709
03-21-2019 16:20 EDT	03-21-2019 16:25 EDT	709
03-21-2019 16:25 EDT	03-21-2019 16:30 EDT	709
03-21-2019 16:30 EDT	03-21-2019 16:35 EDT	709
03-21-2019 16:35 EDT	03-21-2019 16:40 EDT	709

EURICE5  
SCR/Oxidation Catalyst Inlet Temperature

Start Time	End Time	Value/Average (Deg F)
03-27-2019 08:15 EDT	03-27-2019 08:20 EDT	694
03-27-2019 08:20 EDT	03-27-2019 08:25 EDT	695
03-27-2019 08:25 EDT	03-27-2019 08:30 EDT	696
03-27-2019 08:30 EDT	03-27-2019 08:35 EDT	696
03-27-2019 08:35 EDT	03-27-2019 08:40 EDT	696
03-27-2019 08:40 EDT	03-27-2019 08:45 EDT	696
03-27-2019 08:45 EDT	03-27-2019 08:50 EDT	697
03-27-2019 08:50 EDT	03-27-2019 08:55 EDT	696
03-27-2019 08:55 EDT	03-27-2019 09:00 EDT	696
03-27-2019 09:00 EDT	03-27-2019 09:05 EDT	696
03-27-2019 09:05 EDT	03-27-2019 09:10 EDT	696
03-27-2019 09:10 EDT	03-27-2019 09:15 EDT	696
03-27-2019 09:15 EDT	03-27-2019 09:20 EDT	696
03-27-2019 09:20 EDT	03-27-2019 09:25 EDT	695
03-27-2019 09:25 EDT	03-27-2019 09:30 EDT	694
03-27-2019 09:30 EDT	03-27-2019 09:35 EDT	694
03-27-2019 09:35 EDT	03-27-2019 09:40 EDT	694
03-27-2019 09:40 EDT	03-27-2019 09:45 EDT	694
03-27-2019 09:45 EDT	03-27-2019 09:50 EDT	694
03-27-2019 09:50 EDT	03-27-2019 09:55 EDT	694
03-27-2019 09:55 EDT	03-27-2019 10:00 EDT	695
03-27-2019 10:00 EDT	03-27-2019 10:05 EDT	694
03-27-2019 10:05 EDT	03-27-2019 10:10 EDT	694
03-27-2019 10:10 EDT	03-27-2019 10:15 EDT	694
03-27-2019 10:15 EDT	03-27-2019 10:20 EDT	694
03-27-2019 10:20 EDT	03-27-2019 10:25 EDT	694
03-27-2019 10:25 EDT	03-27-2019 10:30 EDT	694
03-27-2019 10:30 EDT	03-27-2019 10:35 EDT	695
03-27-2019 10:35 EDT	03-27-2019 10:40 EDT	694
03-27-2019 10:40 EDT	03-27-2019 10:45 EDT	694
03-27-2019 10:45 EDT	03-27-2019 10:50 EDT	694
03-27-2019 10:50 EDT	03-27-2019 10:55 EDT	694
03-27-2019 10:55 EDT	03-27-2019 11:00 EDT	694
03-27-2019 11:00 EDT	03-27-2019 11:05 EDT	694
03-27-2019 11:05 EDT	03-27-2019 11:10 EDT	694
03-27-2019 11:10 EDT	03-27-2019 11:15 EDT	694
03-27-2019 11:15 EDT	03-27-2019 11:20 EDT	694
03-27-2019 11:20 EDT	03-27-2019 11:25 EDT	694
03-27-2019 11:25 EDT	03-27-2019 11:30 EDT	695
03-27-2019 11:30 EDT	03-27-2019 11:35 EDT	696
03-27-2019 11:35 EDT	03-27-2019 11:40 EDT	696
03-27-2019 11:40 EDT	03-27-2019 11:45 EDT	696
03-27-2019 11:45 EDT	03-27-2019 11:50 EDT	696
03-27-2019 11:50 EDT	03-27-2019 11:55 EDT	696
03-27-2019 11:55 EDT	03-27-2019 12:00 EDT	696
03-27-2019 12:00 EDT	03-27-2019 12:05 EDT	696

03-27-2019 12:05 EDT	03-27-2019 12:10 EDT	696
03-27-2019 12:10 EDT	03-27-2019 12:15 EDT	695
03-27-2019 12:15 EDT	03-27-2019 12:20 EDT	695
03-27-2019 12:20 EDT	03-27-2019 12:25 EDT	696
03-27-2019 12:25 EDT	03-27-2019 12:30 EDT	696
03-27-2019 12:30 EDT	03-27-2019 12:35 EDT	695
03-27-2019 12:35 EDT	03-27-2019 12:40 EDT	694
03-27-2019 12:40 EDT	03-27-2019 12:45 EDT	694
03-27-2019 12:45 EDT	03-27-2019 12:50 EDT	696
03-27-2019 12:50 EDT	03-27-2019 12:55 EDT	696
03-27-2019 12:55 EDT	03-27-2019 13:00 EDT	696
03-27-2019 13:00 EDT	03-27-2019 13:05 EDT	696
03-27-2019 13:05 EDT	03-27-2019 13:10 EDT	696
03-27-2019 13:10 EDT	03-27-2019 13:15 EDT	696
03-27-2019 13:15 EDT	03-27-2019 13:20 EDT	696
03-27-2019 13:20 EDT	03-27-2019 13:25 EDT	696
03-27-2019 13:25 EDT	03-27-2019 13:30 EDT	697
03-27-2019 13:30 EDT	03-27-2019 13:35 EDT	697
03-27-2019 13:35 EDT	03-27-2019 13:40 EDT	697
03-27-2019 13:40 EDT	03-27-2019 13:45 EDT	697
03-27-2019 13:45 EDT	03-27-2019 13:50 EDT	697
03-27-2019 13:50 EDT	03-27-2019 13:55 EDT	697
03-27-2019 13:55 EDT	03-27-2019 14:00 EDT	697
03-27-2019 14:00 EDT	03-27-2019 14:05 EDT	698
03-27-2019 14:05 EDT	03-27-2019 14:10 EDT	698
03-27-2019 14:10 EDT	03-27-2019 14:15 EDT	698
03-27-2019 14:15 EDT	03-27-2019 14:20 EDT	698
03-27-2019 14:20 EDT	03-27-2019 14:25 EDT	698
03-27-2019 14:25 EDT	03-27-2019 14:30 EDT	698
03-27-2019 14:30 EDT	03-27-2019 14:35 EDT	698
03-27-2019 14:35 EDT	03-27-2019 14:40 EDT	698
03-27-2019 14:40 EDT	03-27-2019 14:45 EDT	698
03-27-2019 14:45 EDT	03-27-2019 14:50 EDT	698
03-27-2019 14:50 EDT	03-27-2019 14:55 EDT	698
03-27-2019 14:55 EDT	03-27-2019 15:00 EDT	697
03-27-2019 15:00 EDT	03-27-2019 15:05 EDT	698
03-27-2019 15:05 EDT	03-27-2019 15:10 EDT	697
03-27-2019 15:10 EDT	03-27-2019 15:15 EDT	696
03-27-2019 15:15 EDT	03-27-2019 15:20 EDT	696
03-27-2019 15:20 EDT	03-27-2019 15:25 EDT	696

EURICE6  
SCR/Oxidation Catalyst Inlet Temperature

Start Time	End Time	Value/Average (Deg F)
03-26-2019 08:30 EDT	03-26-2019 08:35 EDT	700
03-26-2019 08:35 EDT	03-26-2019 08:40 EDT	700
03-26-2019 08:40 EDT	03-26-2019 08:45 EDT	699
03-26-2019 08:45 EDT	03-26-2019 08:50 EDT	699
03-26-2019 08:50 EDT	03-26-2019 08:55 EDT	698
03-26-2019 08:55 EDT	03-26-2019 09:00 EDT	698
03-26-2019 09:00 EDT	03-26-2019 09:05 EDT	698
03-26-2019 09:05 EDT	03-26-2019 09:10 EDT	698
03-26-2019 09:10 EDT	03-26-2019 09:15 EDT	697
03-26-2019 09:15 EDT	03-26-2019 09:20 EDT	697
03-26-2019 09:20 EDT	03-26-2019 09:25 EDT	697
03-26-2019 09:25 EDT	03-26-2019 09:30 EDT	698
03-26-2019 09:30 EDT	03-26-2019 09:35 EDT	697
03-26-2019 09:35 EDT	03-26-2019 09:40 EDT	697
03-26-2019 09:40 EDT	03-26-2019 09:45 EDT	697
03-26-2019 09:45 EDT	03-26-2019 09:50 EDT	697
03-26-2019 09:50 EDT	03-26-2019 09:55 EDT	697
03-26-2019 09:55 EDT	03-26-2019 10:00 EDT	696
03-26-2019 10:00 EDT	03-26-2019 10:05 EDT	696
03-26-2019 10:05 EDT	03-26-2019 10:10 EDT	696
03-26-2019 10:10 EDT	03-26-2019 10:15 EDT	696
03-26-2019 10:15 EDT	03-26-2019 10:20 EDT	696
03-26-2019 10:20 EDT	03-26-2019 10:25 EDT	696
03-26-2019 10:25 EDT	03-26-2019 10:30 EDT	696
03-26-2019 10:30 EDT	03-26-2019 10:35 EDT	698
03-26-2019 10:35 EDT	03-26-2019 10:40 EDT	698
03-26-2019 10:40 EDT	03-26-2019 10:45 EDT	698
03-26-2019 10:45 EDT	03-26-2019 10:50 EDT	698
03-26-2019 10:50 EDT	03-26-2019 10:55 EDT	698
03-26-2019 10:55 EDT	03-26-2019 11:00 EDT	690
03-26-2019 11:00 EDT	03-26-2019 11:05 EDT	696
03-26-2019 11:05 EDT	03-26-2019 11:10 EDT	696
03-26-2019 11:10 EDT	03-26-2019 11:15 EDT	696
03-26-2019 11:15 EDT	03-26-2019 11:20 EDT	696
03-26-2019 11:20 EDT	03-26-2019 11:25 EDT	696
03-26-2019 11:25 EDT	03-26-2019 11:30 EDT	696
03-26-2019 11:30 EDT	03-26-2019 11:35 EDT	696
03-26-2019 11:35 EDT	03-26-2019 11:40 EDT	696
03-26-2019 11:40 EDT	03-26-2019 11:45 EDT	696
03-26-2019 11:45 EDT	03-26-2019 11:50 EDT	696
03-26-2019 11:50 EDT	03-26-2019 11:55 EDT	696
03-26-2019 11:55 EDT	03-26-2019 12:00 EDT	696
03-26-2019 12:00 EDT	03-26-2019 12:05 EDT	696
03-26-2019 12:05 EDT	03-26-2019 12:10 EDT	696
03-26-2019 12:10 EDT	03-26-2019 12:15 EDT	696
03-26-2019 12:15 EDT	03-26-2019 12:20 EDT	696



03-26-2019 12:20 EDT	03-26-2019 12:25 EDT	696
03-26-2019 12:25 EDT	03-26-2019 12:30 EDT	696
03-26-2019 12:30 EDT	03-26-2019 12:35 EDT	696
03-26-2019 12:35 EDT	03-26-2019 12:40 EDT	696
03-26-2019 12:40 EDT	03-26-2019 12:45 EDT	696
03-26-2019 12:45 EDT	03-26-2019 12:50 EDT	695
03-26-2019 12:50 EDT	03-26-2019 12:55 EDT	695
03-26-2019 12:55 EDT	03-26-2019 13:00 EDT	695
03-26-2019 13:00 EDT	03-26-2019 13:05 EDT	695
03-26-2019 13:05 EDT	03-26-2019 13:10 EDT	695
03-26-2019 13:10 EDT	03-26-2019 13:15 EDT	696
03-26-2019 13:15 EDT	03-26-2019 13:20 EDT	696
03-26-2019 13:20 EDT	03-26-2019 13:25 EDT	696
03-26-2019 13:25 EDT	03-26-2019 13:30 EDT	696
03-26-2019 13:30 EDT	03-26-2019 13:35 EDT	696
03-26-2019 13:35 EDT	03-26-2019 13:40 EDT	695
03-26-2019 13:40 EDT	03-26-2019 13:45 EDT	694
03-26-2019 13:45 EDT	03-26-2019 13:50 EDT	694
03-26-2019 13:50 EDT	03-26-2019 13:55 EDT	694
03-26-2019 13:55 EDT	03-26-2019 14:00 EDT	694
03-26-2019 14:00 EDT	03-26-2019 14:05 EDT	694
03-26-2019 14:05 EDT	03-26-2019 14:10 EDT	694
03-26-2019 14:10 EDT	03-26-2019 14:15 EDT	694
03-26-2019 14:15 EDT	03-26-2019 14:20 EDT	694
03-26-2019 14:20 EDT	03-26-2019 14:25 EDT	693
03-26-2019 14:25 EDT	03-26-2019 14:30 EDT	693
03-26-2019 14:30 EDT	03-26-2019 14:35 EDT	693
03-26-2019 14:35 EDT	03-26-2019 14:40 EDT	693
03-26-2019 14:40 EDT	03-26-2019 14:45 EDT	693
03-26-2019 14:45 EDT	03-26-2019 14:50 EDT	693
03-26-2019 14:50 EDT	03-26-2019 14:55 EDT	693
03-26-2019 14:55 EDT	03-26-2019 15:00 EDT	693
03-26-2019 15:00 EDT	03-26-2019 15:05 EDT	693
03-26-2019 15:05 EDT	03-26-2019 15:10 EDT	693
03-26-2019 15:10 EDT	03-26-2019 15:15 EDT	693
03-26-2019 15:15 EDT	03-26-2019 15:20 EDT	680
03-26-2019 15:20 EDT	03-26-2019 15:25 EDT	696
03-26-2019 15:25 EDT	03-26-2019 15:30 EDT	696
03-26-2019 15:30 EDT	03-26-2019 15:35 EDT	696
03-26-2019 15:35 EDT	03-26-2019 15:40 EDT	696
03-26-2019 15:40 EDT	03-26-2019 15:45 EDT	696
03-26-2019 15:45 EDT	03-26-2019 15:50 EDT	696
03-26-2019 15:50 EDT	03-26-2019 15:55 EDT	696

EURICE7  
SCR/Oxidation Catalyst Inlet Temperature

Start Time	End Time	Value/Average (Deg F)
03-28-2019 08:15 EDT	03-28-2019 08:20 EDT	698
03-28-2019 08:20 EDT	03-28-2019 08:25 EDT	699
03-28-2019 08:25 EDT	03-28-2019 08:30 EDT	700
03-28-2019 08:30 EDT	03-28-2019 08:35 EDT	700
03-28-2019 08:35 EDT	03-28-2019 08:40 EDT	699
03-28-2019 08:40 EDT	03-28-2019 08:45 EDT	698
03-28-2019 08:45 EDT	03-28-2019 08:50 EDT	698
03-28-2019 08:50 EDT	03-28-2019 08:55 EDT	698
03-28-2019 08:55 EDT	03-28-2019 09:00 EDT	698
03-28-2019 09:00 EDT	03-28-2019 09:05 EDT	698
03-28-2019 09:05 EDT	03-28-2019 09:10 EDT	698
03-28-2019 09:10 EDT	03-28-2019 09:15 EDT	698
03-28-2019 09:15 EDT	03-28-2019 09:20 EDT	698
03-28-2019 09:20 EDT	03-28-2019 09:25 EDT	698
03-28-2019 09:25 EDT	03-28-2019 09:30 EDT	698
03-28-2019 09:30 EDT	03-28-2019 09:35 EDT	698
03-28-2019 09:35 EDT	03-28-2019 09:40 EDT	698
03-28-2019 09:40 EDT	03-28-2019 09:45 EDT	698
03-28-2019 09:45 EDT	03-28-2019 09:50 EDT	698
03-28-2019 09:50 EDT	03-28-2019 09:55 EDT	697
03-28-2019 09:55 EDT	03-28-2019 10:00 EDT	698
03-28-2019 10:00 EDT	03-28-2019 10:05 EDT	696
03-28-2019 10:05 EDT	03-28-2019 10:10 EDT	697
03-28-2019 10:10 EDT	03-28-2019 10:15 EDT	697
03-28-2019 10:15 EDT	03-28-2019 10:20 EDT	698
03-28-2019 10:20 EDT	03-28-2019 10:25 EDT	697
03-28-2019 10:25 EDT	03-28-2019 10:30 EDT	696
03-28-2019 10:30 EDT	03-28-2019 10:35 EDT	696
03-28-2019 10:35 EDT	03-28-2019 10:40 EDT	697
03-28-2019 10:40 EDT	03-28-2019 10:45 EDT	698
03-28-2019 10:45 EDT	03-28-2019 10:50 EDT	698
03-28-2019 10:50 EDT	03-28-2019 10:55 EDT	698
03-28-2019 10:55 EDT	03-28-2019 11:00 EDT	697
03-28-2019 11:00 EDT	03-28-2019 11:05 EDT	697
03-28-2019 11:05 EDT	03-28-2019 11:10 EDT	697
03-28-2019 11:10 EDT	03-28-2019 11:15 EDT	696
03-28-2019 11:15 EDT	03-28-2019 11:20 EDT	697
03-28-2019 11:20 EDT	03-28-2019 11:25 EDT	696
03-28-2019 11:25 EDT	03-28-2019 11:30 EDT	696
03-28-2019 11:30 EDT	03-28-2019 11:35 EDT	696
03-28-2019 11:35 EDT	03-28-2019 11:40 EDT	696
03-28-2019 11:40 EDT	03-28-2019 11:45 EDT	696
03-28-2019 11:45 EDT	03-28-2019 11:50 EDT	696
03-28-2019 11:50 EDT	03-28-2019 11:55 EDT	696
03-28-2019 11:55 EDT	03-28-2019 12:00 EDT	696
03-28-2019 12:00 EDT	03-28-2019 12:05 EDT	696

03-28-2019 12:05 EDT	03-28-2019 12:10 EDT	696
03-28-2019 12:10 EDT	03-28-2019 12:15 EDT	695
03-28-2019 12:15 EDT	03-28-2019 12:20 EDT	695
03-28-2019 12:20 EDT	03-28-2019 12:25 EDT	695
03-28-2019 12:25 EDT	03-28-2019 12:30 EDT	694
03-28-2019 12:30 EDT	03-28-2019 12:35 EDT	694
03-28-2019 12:35 EDT	03-28-2019 12:40 EDT	694

03-29-2019 07:55 EDT	03-29-2019 08:00 EDT	695
03-29-2019 08:00 EDT	03-29-2019 08:05 EDT	695
03-29-2019 08:05 EDT	03-29-2019 08:10 EDT	696
03-29-2019 08:10 EDT	03-29-2019 08:15 EDT	696
03-29-2019 08:15 EDT	03-29-2019 08:20 EDT	696
03-29-2019 08:20 EDT	03-29-2019 08:25 EDT	696
03-29-2019 08:25 EDT	03-29-2019 08:30 EDT	696
03-29-2019 08:30 EDT	03-29-2019 08:35 EDT	696
03-29-2019 08:35 EDT	03-29-2019 08:40 EDT	696
03-29-2019 08:40 EDT	03-29-2019 08:45 EDT	696
03-29-2019 08:45 EDT	03-29-2019 08:50 EDT	696
03-29-2019 08:50 EDT	03-29-2019 08:55 EDT	696
03-29-2019 08:55 EDT	03-29-2019 09:00 EDT	696
03-29-2019 09:00 EDT	03-29-2019 09:05 EDT	696
03-29-2019 09:05 EDT	03-29-2019 09:10 EDT	696
03-29-2019 09:10 EDT	03-29-2019 09:15 EDT	696
03-29-2019 09:15 EDT	03-29-2019 09:20 EDT	698
03-29-2019 09:20 EDT	03-29-2019 09:25 EDT	697
03-29-2019 09:25 EDT	03-29-2019 09:30 EDT	696
03-29-2019 09:30 EDT	03-29-2019 09:35 EDT	698
03-29-2019 09:35 EDT	03-29-2019 09:40 EDT	698
03-29-2019 09:40 EDT	03-29-2019 09:45 EDT	698
03-29-2019 09:45 EDT	03-29-2019 09:50 EDT	698
03-29-2019 09:50 EDT	03-29-2019 09:55 EDT	697
03-29-2019 09:55 EDT	03-29-2019 10:00 EDT	700
03-29-2019 10:00 EDT	03-29-2019 10:05 EDT	735

## Appendix B - Test Section Diagrams

## GASEOUS TRAVERSE FOR ROUND DUCTS

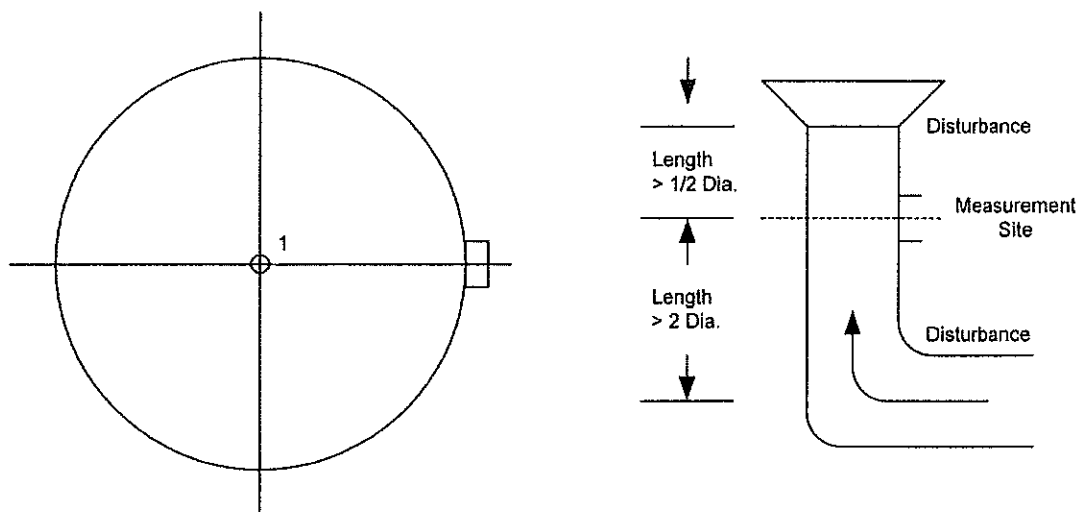

Job: Upper Michigan Energy Resources Corporation  
F. D. Kuester Generating Station

Date: March 19 through March 28, 2019

Test Location: EURICE1, EURICE2, EURICE3, EURICE4, EURICE5, EURICE6,  
EURICE7 Outlet Duct

Duct Diameter: 5.29 Feet

Duct Area: 21.979 Square Feet

No. Points Across Diameter: 1

No. of Ports: 1

Port Length: 8.0 Inches

## Appendix C - Sample Train Diagrams

# USEPA Methods 3A and 320 – Sample Train Diagram

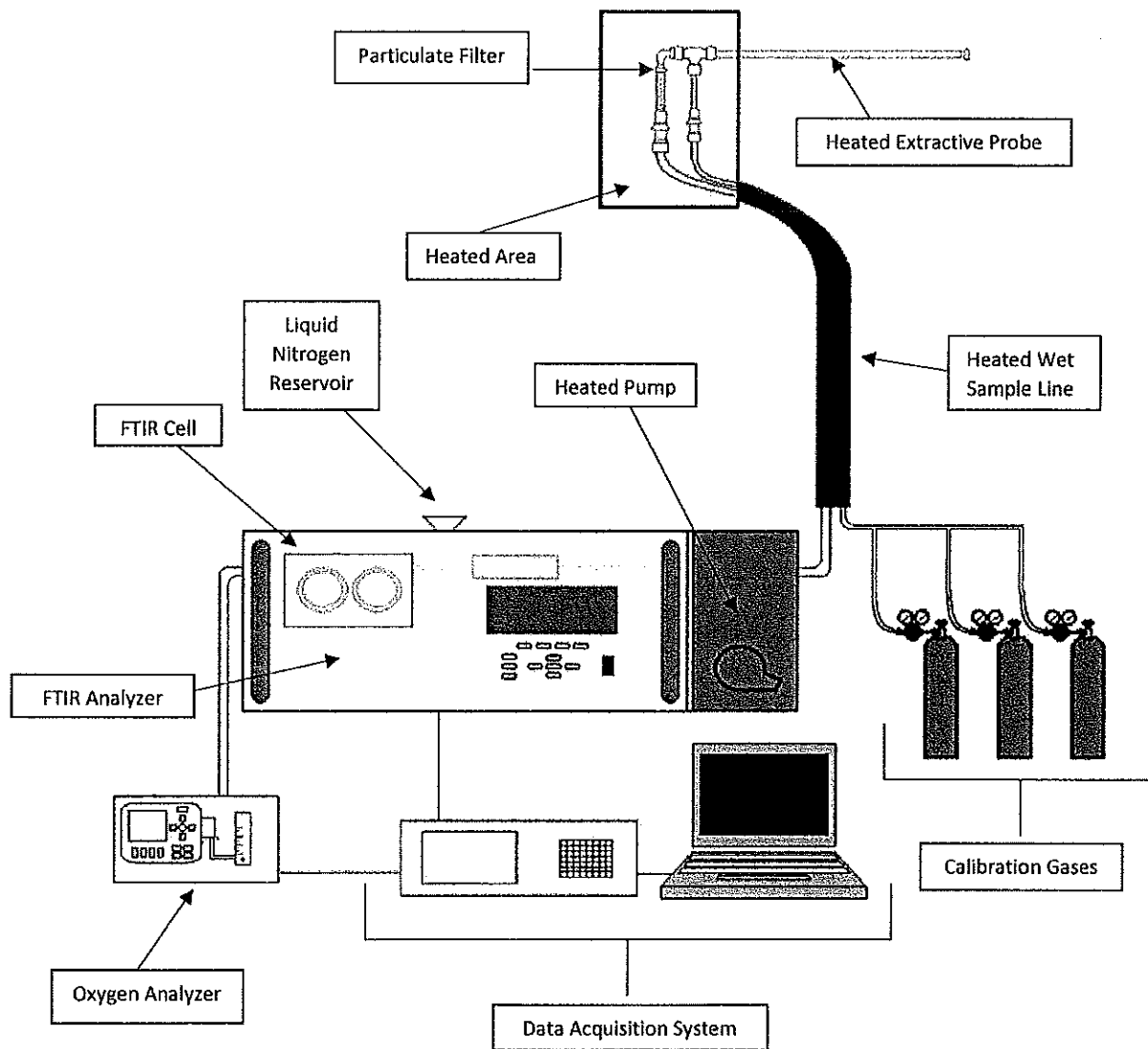

## Appendix D - Calculation Nomenclature and Formulas