



PO797

Upper Michigan Energy
Resources Corporation
231 W. Michigan St.
Milwaukee, WI 53203

UNITED PARCEL SERVICE

May 2, 2019

Mr. Joseph Scanlan
Michigan Department of Environment, Great Lakes, and Energy
Air Quality Division
1504 West Washington Street
Marquette, MI 49855

RECEIVED

MAY 06 2019

AIR QUALITY DIVISION

**Subject: F.D. Kuester Generating Station
Negaunee, Michigan
Permit to Install 35-17 and 40 CFR Part 60 Subpart JJJJ
EURICE1, EURICE2, EURICE3, EURICE4, EURICE5, EURICE6, and EURICE7
Compliance Emissions Test Report Submittal**

Dear Mr. Scanlan:

Upper Michigan Energy Resources Corporation (UMERC) respectfully submits the results of reciprocating internal combustion engine (RICE) initial compliance testing conducted at the F.D. Kuester Generating Station units EURICE1, EURICE2, EURICE3, EURICE4, EURICE5, EURICE6, and EURICE7 during the period March 19-29, 2019.

The results demonstrate compliance with the conditions of Permit To Install 35-17 and 40 CFR Part 60 Subpart JJJJ. A summary of results by emission unit is presented below.

Source	Pollutant	Test Result	Permit Limit
EURICE1	NOx	2.8 lb/hr	3.0 lb/hr
EURICE1	NOx	4.7 ppmvd @ 15% O2	82 ppmvd @ 15% O2
EURICE1	CO	2.3 lb/hr	5.5 lb/hr
EURICE1	CO	6.3 ppmvd @ 15% O2	270 ppmvd @ 15% O2
EURICE1	VOC	3.6 lb/hr	5.5 lb/hr
EURICE1	VOC	6.4 ppmvd @ 15% O2	60 ppmvd @ 15% O2
EURICE1	TPM	0.358 lb/hr	3.72 lb/hr

Source	Pollutant	Test Result	Permit Limit
EURICE2	NOx	1.0 lb/hr	3.0 lb/hr
EURICE2	NOx	1.8 ppmvd @ 15% O2	82 ppmvd @ 15% O2
EURICE2	CO	1.2 lb/hr	5.5 lb/hr
EURICE2	CO	3.3 ppmvd @ 15% O2	270 ppmvd @ 15% O2
EURICE2	VOC	1.0 lb/hr	5.5 lb/hr
EURICE2	VOC	1.8 ppmvd @ 15% O2	60 ppmvd @ 15% O2
EURICE2	TPM	0.605 lb/hr	3.72 lb/hr

Source	Pollutant	Test Result	Permit Limit
EURICE3	NOx	2.8 lb/hr	3.0 lb/hr
EURICE3	NOx	4.7 ppmvd @ 15% O2	82 ppmvd @ 15% O2
EURICE3	CO	2.7 lb/hr	5.5 lb/hr
EURICE3	CO	7.3 ppmvd @ 15% O2	270 ppmvd @ 15% O2
EURICE3	VOC	3.9 lb/hr	5.5 lb/hr
EURICE3	VOC	6.9 ppmvd @ 15% O2	60 ppmvd @ 15% O2
EURICE3	TPM	0.586 lb/hr	3.72 lb/hr

Source	Pollutant	Test Result	Permit Limit
EURICE4	NOx	0.8 lb/hr	3.0 lb/hr
EURICE4	NOx	1.2 ppmvd @ 15% O2	82 ppmvd @ 15% O2
EURICE4	CO	1.0 lb/hr	5.5 lb/hr
EURICE4	CO	2.7 ppmvd @ 15% O2	270 ppmvd @ 15% O2
EURICE4	VOC	1.2 lb/hr	5.5 lb/hr
EURICE4	VOC	2.0 ppmvd @ 15% O2	60 ppmvd @ 15% O2
EURICE4	TPM	0.602 lb/hr	3.72 lb/hr

Source	Pollutant	Test Result	Permit Limit
EURICE5	NOx	2.6 lb/hr	3.0 lb/hr
EURICE5	NOx	4.7 ppmvd @ 15% O2	82 ppmvd @ 15% O2
EURICE5	CO	2.3 lb/hr	5.5 lb/hr
EURICE5	CO	6.8 ppmvd @ 15% O2	270 ppmvd @ 15% O2
EURICE5	VOC	0.8 lb/hr	5.5 lb/hr
EURICE5	VOC	1.7 ppmvd @ 15% O2	60 ppmvd @ 15% O2
EURICE5	TPM	0.660 lb/hr	3.72 lb/hr

Source	Pollutant	Test Result	Permit Limit
EURICE6	NOx	1.9 lb/hr	3.0 lb/hr
EURICE6	NOx	3.2 ppmvd @ 15% O2	82 ppmvd @ 15% O2
EURICE6	CO	1.2 lb/hr	5.5 lb/hr
EURICE6	CO	3.2 ppmvd @ 15% O2	270 ppmvd @ 15% O2
EURICE6	VOC	1.2 lb/hr	5.5 lb/hr
EURICE6	VOC	2.2 ppmvd @ 15% O2	60 ppmvd @ 15% O2
EURICE6	TPM	0.493 lb/hr	3.72 lb/hr

Source	Pollutant	Test Result	Permit Limit
EURICE7	NOx	2.6 lb/hr	3.0 lb/hr
EURICE7	NOx	4.7 ppmvd @ 15% O2	82 ppmvd @ 15% O2
EURICE7	CO	2.3 lb/hr	5.5 lb/hr
EURICE7	CO	6.8 ppmvd @ 15% O2	270 ppmvd @ 15% O2
EURICE7	VOC	2.4 lb/hr	5.5 lb/hr
EURICE7	VOC	4.5 ppmvd @ 15% O2	60 ppmvd @ 15% O2
EURICE7	TPM	0.546 lb/hr	3.72 lb/hr

Enclosed please find the following Mostardi Platt test reports:

- *Compliance Emissions Test Report, Performed for: Upper Michigan Energy Resources Corporation, At The: F.D. Kuester Generating Station, EURICE1 Outlet Duct, Negaunee, Michigan, Project No. M191105A, March 19, 2019*
- *Compliance Emissions Test Report, Performed for: Upper Michigan Energy Resources Corporation, At The: F.D. Kuester Generating Station, EURICE2 Outlet Duct, Negaunee, Michigan, Project No. M191105B, March 25, 2019*
- *Compliance Emissions Test Report, Performed for: Upper Michigan Energy Resources Corporation, At The: F.D. Kuester Generating Station, EURICE3 Outlet Duct, Negaunee, Michigan, Project No. M191105C, March 20, 2019*
- *Compliance Emissions Test Report, Performed for: Upper Michigan Energy Resources Corporation, At The: F.D. Kuester Generating Station, EURICE4 Outlet Duct, Negaunee, Michigan, Project No. M191105D, March 21, 2019*
- *Compliance Emissions Test Report, Performed for: Upper Michigan Energy Resources Corporation, At The: F.D. Kuester Generating Station, EURICE5 Outlet Duct, Negaunee, Michigan, Project No. M191105E, March 27, 2019*
- *Compliance Emissions Test Report, Performed for: Upper Michigan Energy Resources Corporation, At The: F.D. Kuester Generating Station, EURICE6 Outlet Duct, Negaunee, Michigan, Project No. M191105F, March 26, 2019*
- *Compliance Emissions Test Report, Performed for: Upper Michigan Energy Resources Corporation, At The: F.D. Kuester Generating Station, EURICE7 Outlet Duct, Negaunee, Michigan, Project No. M191105G, March 28 and 29, 2019*

If you have any questions or need additional information, please contact me at (414) 221-2389 or laura.jarmuz@wecenergygroup.com.

Sincerely,



Laura Jarmuz
Senior Engineer

cc: Karen Kajiya-Mills, Technical Programs Unit, EGLE, Air Quality Division
Ed Lancaster, District Supervisor, EGLE, Air Quality Division—w/o enclosures
Scott Johnson, UMER—electronic w/o enclosures
Justin Kowalski, UMER—electronic w/o enclosures

Enclosures:

1. Mostardi Platt Project No. M191105A Report
2. Mostardi Platt Project No. M191105B Report
3. Mostardi Platt Project No. M191105C Report
4. Mostardi Platt Project No. M191105D Report
5. Mostardi Platt Project No. M191105E Report
6. Mostardi Platt Project No. M191105F Report
7. Mostardi Platt Project No. M191105G Report



Compliance Emissions Test Report

**Performed for: Upper Michigan Energy Resources
Corporation
At The: F.D. Kuester Generating Station
Permit No. 35-17
EURICE5 Outlet Duct
Negaunee, Michigan
March 27, 2019**

**Report Submittal Date
April 29, 2019**

© Copyright 2019
All rights reserved in
Mostardi Platt

Project No. M191105E

TABLE OF CONTENTS

1.0 EXECUTIVE SUMMARY	1
2.0 TEST METHODOLOGY	2
Method 1 Traverse Point Determination	2
Method 2 Volumetric Flowrate Determination	3
Method 3A Oxygen (O ₂)/Carbon Dioxide (CO ₂) Determination	3
Method 5 Particulate Determination	3
Method 7E Nitrogen Oxide (NO _x) Determination	3
Method 10 Carbon Monoxide (CO) Determination	4
Method 25A Volatile Organic Compound (VOC) Determination	4
Method 202 Condensable Particulate Determination	4
Method 320 Fourier Transform Infrared (FTIR) Detector for Methane and Ethane Determination	5
3.0 TEST RESULT SUMMARY	8
4.0 CERTIFICATION	10
APPENDIX	
Appendix A – Plant Operating Data	12
Appendix B - Test Section Diagrams	16
Appendix C - Sample Train Diagrams	20
Appendix D - Calculation Nomenclature and Formulas	26
Appendix E - Reference Method Test Data (Computerized Sheets)	41
Appendix F - Field Data Sheets	57
Appendix G - Calibration Data	65
Appendix H - Laboratory Data	86
Appendix I - FTIR QA/QC	94
Appendix J - Gas Cylinder Calibrations	97

1.0 EXECUTIVE SUMMARY

MOSTARDI PLATT conducted a compliance emissions test program for Upper Michigan Energy Resources Corporation (UMERC) on March 27, 2019 at F.D. Kuester Generating Station on the Reciprocating Internal Combustion Engine 5 (EURICE5) Outlet Duct in Negaunee, Michigan. The purpose of the test program was to meet the initial compliance demonstration requirements for emission rates in accordance with Permit to Install 35-17 and 40 CFR Part 60 Subpart JJJJ. This report summarizes the results of the test program and test methods used.

The test location, test date, and test parameters are summarized below.

Test Location	Test Date	Test Parameters
EURICE5 Outlet Duct	March 27, 2019	Nitrogen Oxides (NO _x), Carbon Monoxide (CO), Carbon Dioxide (CO ₂), Oxygen (O ₂), Volatile Organic Compounds (VOCs), Total Particulate Matter (TPM), Volumetric Flow, and Moisture

F.D. Kuester Generating Station electric generation facility includes seven (7) Wärtsilä W18V50SG natural gas-fired, four stroke, lean burn, spark ignition reciprocating internal combustion engines (RICE) coupled to 18,817 kW electric generators, a 1,000 kW natural gas-fired emergency generator, and one natural gas-fired natural gas conditioning heater. The RICE electric generating unit engines utilize pipeline quality natural gas and are equipped with selective catalytic reduction (SCR) for nitrogen oxides (NO_x) control and oxidation catalyst systems for carbon monoxide (CO), volatile organic compound (VOC), and organic hazardous air pollutant (HAP) control. Each RICE electric generating unit exhausts into a common stack.

Selected results of the test program are summarized below. A complete summary of emission test results follows the narrative portion of this report.

TEST RESULTS				
Test Location	Test Date	Test Parameter	Emission Rate	Emission Limit
EURICE5 Outlet Duct	3/27/19	NO _x	4.7 ppmvd @ 15% O ₂	82 ppmvd @ 15% O ₂
			2.6 lb/hr	3.0 lb/hr
		CO	6.8 ppmvd @ 15% O ₂	270 ppmvd @ 15% O ₂
			2.3 lb/hr	5.5 lb/hr
		VOC (as C ₃ H ₈)	1.7 ppmvd @ 15% O ₂	60 ppmvd @ 15% O ₂
			0.8 lb/hr	5.5 lb/hr
TPM	0.660 lb/hr	3.72 lb/hr		

Operating data as provided by the plant is included in Appendix A.

The identifications of the individuals associated with the test program are summarized below.

TEST PERSONNEL INFORMATION		
Location	Address	Contact
Test Coordinator	WEC Energy Group, Inc 231 W. Michigan Street Milwaukee, Wisconsin 53203	Ms. Laura Jarmuz Senior Engineer (414)-221-2389 office Laura.jarmuz@wecenergygroup.com
Test Facility	Upper Michigan Energy Resources Corporation F.D. Kuester Generating Station 80 Eagle Mills Road Negaunee, MI 49866	
Testing Company Representative	Mostardi Platt 888 Industrial Drive Elmhurst, Illinois 60126	Mr. Richard Sollars (630) 993-2100 (phone) rsollars@mp-mail.com

The test crew consisted of Messrs. J. Nestor, T. Schmidt, S. Dyra, J. Gross, J. Carlson, K. Krofel and R. Sollars of Mostardi Platt.

2.0 TEST METHODOLOGY

Emission testing was conducted following the methods specified in Code of Federal Regulations, Title 40, Part 60, Appendix A (40CFR60), 40CFR51, and 40CFR63. Schematics of the test section diagrams and sampling trains used are included in Appendix B and C, respectively. Calculation examples and nomenclature are included in Appendix D. Copies of analyzer print-outs and field data sheets for each test run are included in Appendices E and F, respectively.

The following methodologies were used during the test program:

Method 1 Traverse Point Determination

Test measurement points were selected in accordance with Method 1. The characteristics of the measurement location are summarized below.

TEST POINT INFORMATION						
Location	Diameter (Feet)	Area (Square Feet)	Upstream Distance (Inches)	Downstream Distance (Inches)	Test Parameter	Number of Sampling Points
EURICE5 Outlet Duct	5.29	21.979	>0.5	>2.0	Volumetric Flow	16
					NO _x /CO/VOC/O ₂ /CO ₂	12 (strat), 3
					TPM	24

A null point pitot traverse check was performed utilizing a Type S pitot tube prior to any testing to verify the absence of cyclonic flow at each test location per USEPA Method 1, Section 11.4. The null point at the test location averaged 3.8 degrees which meets the requirements. The results can be found in Appendix E.

Method 2 Volumetric Flowrate Determination

Gas velocity was measured following Method 2, for purposes of calculating stack gas volumetric flow rate. An S-type pitot tube, differential pressure gauge, thermocouple and temperature readout were used to determine gas velocity at each sample point. All of the equipment used was calibrated in accordance with the specifications of the Method. Calibration data are presented in Appendix G.

Method 3A Oxygen (O₂)/Carbon Dioxide (CO₂) Determination

Flue gas O₂ was determined in accordance with Method 3A. An ECOM analyzer was used to determine stack gas oxygen content connected to the outlet of the FTIR analyzer.

Flue gas carbon dioxide concentrations and emission rates were determined in accordance with Method 3A. An MKS MultiGas 2030 FTIR spectrometer was used to determine the CO₂ concentrations, in the manner specified in the Method. Nitrogen Content was determined from the difference of CO₂ and O₂.

Stack gas was delivered to the analyzer via a Teflon® sampling line, heated to a minimum temperature of 375°F. The entire system was calibrated in accordance with the Method, using certified calibration gases introduced at the probe, before and after each test run.

All of the equipment used was calibrated in accordance with the specifications of the Method and calibration data are included in Appendix G. Copies of the gas cylinder certifications are included in Appendix J.

Method 5 Particulate Determination

Stack gas particulate concentrations and emission rates were determined in accordance with Method 5, 40 CFR, Part 60, Appendix A at the test location. An Environmental Supply Company, Inc. sampling train was used to sample stack gas at an isokinetic rate, as specified in the Method. Particulate matter in the sample probe was recovered using an acetone rinse. The probe wash and filter catch were analyzed by Mostardi Platt in accordance with the Method in the Elmhurst, Illinois laboratory. Laboratory data are found in Appendix H. All of the equipment used was calibrated in accordance with the specifications of the Method. Field data sheets are provided in Appendix E and calibration data are presented in Appendix G.

Method 7E Nitrogen Oxide (NO_x) Determination

Flue gas nitrogen oxide concentrations and emission rates were determined in accordance with Method 7E. An MKS MultiGas 2030 FTIR spectrometer was used to determine nitrogen oxide concentrations, in the manner specified in the Method.

Stack gas was delivered to the analyzer via a Teflon® sampling line, heated to a minimum temperature of 375°F. The entire system was calibrated in accordance with the Method, using certified calibration gases introduced at the probe, before and after each test run.

A list of calibration gases used and the results of all calibration and other required quality assurance checks can be found in Appendix G. Copies of calibration gas certifications can be found in Appendix J.

Method 10 Carbon Monoxide (CO) Determination

Flue gas nitrogen oxide concentrations and emission rates were determined in accordance with Method 10. An MKS MultiGas 2030 FTIR spectrometer was used to determine carbon monoxide concentrations, in the manner specified in the Method.

Stack gas was delivered to the analyzer via a Teflon® sampling line, heated to a minimum temperature of 375°F. The entire system was calibrated in accordance with the Method, using certified calibration gases introduced at the probe, before and after each test run.

A list of calibration gases used and the results of all calibration and other required quality assurance checks can be found in Appendix G. Copies of calibration gas certifications can be found in Appendix J.

Method 25A Volatile Organic Compound (VOC) Determination

Total hydrocarbon (THC) concentrations and emission rates were determined in accordance with Method 25A. A Thermo Fisher 51i analyzer was used to determine THC concentrations. Stack gas was delivered to the system via a Teflon® sampling line, heated to a minimum temperature of 375°F.

Methane and ethane concentrations were determined in accordance with Method 320 and then subtracted from the THC concentrations in order to comply with non-methane, non-ethane hydrocarbon criteria as specified in the permit. The methane concentration was also corrected for a response factor for the TECO 51i analyzer. These results can be found in Appendix G along with the calibration data.

The system was calibrated before and after each test run using certified calibration gases of propane for the THC determination. Copies of gas certifications are presented in Appendix J.

Method 202 Condensable Particulate Determination

Stack gas condensable particulate matter concentrations and emission rates were determined in accordance with USEPA Method 202, in conjunction with Method 5 filterable particulate sampling. This method applies to the determination of condensable particulate matter (CPM) emissions from stationary sources. It is intended to represent condensable matter as material that condenses after passing through a filter and as measured by this method.

The CPM was collected in the impinger portion of the Method 5 (Appendix A, 40CFR60) type sampling trains. The impinger contents were immediately purged after each run with nitrogen (N₂) to remove dissolved sulfur dioxide (SO₂) gases from the impinger contents. The impinger solution was then extracted with hexane. The organic and aqueous fractions were then taken to dryness and the residues weighed. A correction was made for any ammonia present due to laboratory analysis procedures. The total of both fractions represents the CPM.

All sample recovery was performed at the test site by the test crew. Mostardi Platt personnel at the laboratory in Elmhurst, Illinois, performed all final particulate sample analyses. Laboratory data are found in Appendix H. All of the equipment used was calibrated in accordance with the specifications of the Method. Calibration data are presented in Appendix G.

Method 320 Fourier Transform Infrared (FTIR) Detector for Methane and Ethane Determination

Flue gas methane, ethane, and moisture concentrations and emission rates were determined in accordance with Method 320. FTIR data was collected using an MKS MultiGas 2030 FTIR spectrometer. The FTIR was equipped with a temperature-controlled, 5.11 meter multi-pass gas cell maintained at 191°C. Gas flows and sampling system pressures were monitored using a rotameter and pressure transducer.

All data was collected at 0.5 cm⁻¹ resolution. Each spectrum was derived from the coaddition of 62 scans, with a new data point generated approximately every one minute. Analyzer data for each run is present in Appendix E.

SAMPLING SYSTEM PARAMETERS				
MKS Serial #	Sampling Line	Probe Assembly	Particulate Filter Media	Operating Temperatures
019088128	100' 3/8" dia., heated Teflon	Heated 3', 3/8" dia. SS	0.01μ heated borosilicate glass fiber	191°C

QA/QC procedures followed US EPA Method 320. See below for QA/QC procedure details and list of calibration gas standards. All calibration gases were introduced to the analyzer and the sampling system using an instrument grade stainless steel rotameter. All QA/QC procedures were within the acceptance criteria allowance of the applicable EPA methodology. See Appendix I for FTIR QA/QC Data.

FTIR QA/QC PROCEDURES						
QA/QC Specification	Purpose	Calibration Gas Analyte	Delivery	Frequency	Acceptance Criteria	Result
M320: Zero	Verify that the FTIR is free of contaminants & zero the FTIR	Nitrogen (zero)	Direct to FTIR	pre/post test	< MDL or Noise	Pass
M320: Calibration Transfer Standard (CTS) Direct	Verify FTIR stability, confirm optical path length	Ethylene	Direct to FTIR	pretest	+/- 5% cert. value	Pass
M320: Analyte Direct	Verify FTIR calibration	Acetaldehyde, Methanol, SF6	Direct to FTIR	pretest	+/- 5% cert. value	Pass
M320: CTS Response	Verify system stability, recovery, response time	Ethylene	Sampling System	Daily, pre/post test	+/- 5% of Direct Measurement	Pass
M320: Zero Response	Verify system is free of system bias	Nitrogen (zero)	Sampling System	pretest	Bias correct data	Pass
M320: Analyte Spike	Verify system ability to deliver and quantify analyte of interest in the presence of effluent gases	Acetaldehyde, Methanol, SF6	Dynamic Addition to Sampling System, 1:10 effluent	Throughout testing – daily	+/- 30% theoretical recovery	Pass

Note: The determined concentrations from direct analyses were used in all system/spike recovery calculations.

CALIBRATION GAS STANDARDS				
Components	Concentration (ppm)	Vendor	Cylinder #	Standard Type
Ethylene	100.0	Airgas	CC111625	Primary +/- 1%
Acetaldehyde/ Methanol/SF6	194.4/195.3/ 4.820	Airgas	CC475635	Certified Standard-Spec +/- 5%
Nitrogen	Zero Gas	Airgas	N/A	UHP Grade

Analyte Spiking

Acetaldehyde and methanol spiking was performed prior to testing to verify the ability of the sampling system to quantitatively deliver a sample containing acetaldehyde and methanol from the base of the probe to the FTIR. Analyte spiking assures the ability of the FTIR sampling system to recover volatile organics in the presence of effluent gas.

As part of the spiking procedure, samples were measured to determine native acetaldehyde and methanol concentrations to be used in the spike recovery calculations. The analyte spiking gases contained a low concentration of sulfur hexafluoride (SF₆). The determined SF₆ concentration in the spiked sample was used to calculate the dilution factor of the spike and thus used to calculate the concentration of the spiked acetaldehyde and methanol. The spike target dilution ratio was 1:10 or less.

The following equation illustrates the percent recovery calculation.

$$DF = \frac{SF6(spik)}{SF6(direct)} \quad (\text{Sec. 9.2.3 (3) USEPA Method 320})$$

$$CS = DF * Spike(dir) + Unspike(1 - DF) \quad (\text{Sec. 9.2.3 (4) USEPA Method 320})$$

DF = Dilution factor of the spike gas

SF_{6(dir)} = SF₆ concentration measured directly in undiluted spike gas

SF_{6(spik)} = Diluted SF₆ concentration measured in a spiked sample

Spike_{dir} = Concentration of the analyte in the spike standard measure by the FTIR directly

CS = Expected concentration of the spiked samples

Unspike = Native concentration of analytes in unspiked samples

Post Collection Data Validation

As part of the data validation procedure, reference spectra are manually fit to that of the sample spectra and a concentration is determined. The reference spectra are scaled to match the peak amplitude of the sample, thus providing a scale factor. The scale factor multiplied by the reference spectra concentration is used to determine the concentration value for the sample spectra. Sample pressure and temperature corrections are then applied to compute the final sample concentration. The manually calculated results are then compared with the software-generated results. The data is then validated if the two concentrations are within ± 20% agreement. If there is a difference greater than ± 20% the spectra are reviewed for possible spectra interferences or any other possible causes leading to incorrectly quantified data.

Detection Limit

The detection limit of each analyte was calculated following Annex A2 of ASTM D6348-12 procedure using spectra that contained similar amounts of moisture and carbon dioxide.

Analyte	Detection Limit (ppmv wet)	Detection Limit (%v)
Methane	1.0	-
Ethane	0.5	-
Moisture	-	0.1

QA/QC data are found in Appendix I. Copies of gas cylinder certifications are found in Appendix J. All concentration data were recorded on a wet, volume basis. The sample and data collection followed the procedures outlined in Method 320.

3.0 TEST RESULT SUMMARY

Upper Michigan Energy Resources Corporation Kuester Generating Station EURICES															
Gaseous Summary															
Test No.	Date	Start Time	End Time	NO _x ppmvd	CO ppmvd	CO ₂ % (dry)	O ₂ % (dry)	Moisture, %	Flowrate, DSCFM	Flowrate, SCFM	THC ppm as C ₃ H ₈ (wet)	CH ₄ ppm as CH ₄ (wet)	CH ₄ ppm as C ₃ H ₈ (wet) *	C ₂ H ₆ ppm as C ₃ H ₈ (wet)	VOC ppm as C ₃ H ₈ (wet)
1	03/27/19	08:15	09:14	7.1	10.1	5.3	11.9	9.2	52,375	57,654	153.8	312.0	125.8	25.1	2.9
2	03/27/19	10:50	11:49	7.0	10.3	5.2	12.2	9.2	51,840	57,280	150.5	307.6	124.1	25.4	1.0
3	03/27/19	13:20	14:19	7.1	10.2	5.2	12.1	9.3	52,085	57,398	153.9	316.9	127.8	23.6	2.5
Average				7.1	10.2	5.2	12.1	9.3	52,100	57,444	152.7	312.2	125.9	24.7	2.1

Emission Rate Summary										
Test No.	Date	Start Time	End Time	Fd Factor, dscf/MMBtu	CO ppmvd @ 15% O ₂	NO _x ppmvd @ 15% O ₂	NMNE ppmvd @ 15% O ₂	NO _x lb/hr	CO lb/hr	NMNE VOC lb/hr as C ₃ H ₈
1	03/27/19	08:15	09:14	8,710.0	6.6	4.7	2.3	2.7	2.3	1.1
2	03/27/19	10:50	11:49	8,710.0	7.0	4.7	0.9	2.6	2.3	0.4
3	03/27/19	13:20	14:19	8,710.0	6.8	4.8	2.0	2.7	2.3	1.0
Average				8,710.0	6.8	4.7	1.7	2.6	2.3	0.8

* Methane is corrected with a response Factor of 1.21 for the TECOS11 analyzer

Client: Upper Michigan Energy Resources Corporation
 Facility: F.D. Kuester Generating Station
 Test Location: EURICE5 Outlet Duct
 Test Method: 5/202

	Source Condition	Full Load	Full Load	Full Load	
	Date	3/27/19	3/27/19	3/27/19	
	Start Time	8:15	10:50	13:20	
	End Time	10:19	12:54	15:24	
	Run 1	Run 2	Run 3	Average	
Stack Conditions					
Average Gas Temperature, °F	699.5	698.3	700.0	699.3	
Flue Gas Moisture, percent by volume	9.2%	9.5%	9.3%	9.3%	
Average Flue Pressure, in. Hg	29.06	29.06	29.06	29.06	
Gas Sample Volume, dscf	83.328	81.822	82.941	82.697	
Average Gas Velocity, ft/sec	98.848	98.100	98.447	98.465	
Gas Volumetric Flow Rate, acfm	130,352	129,367	129,825	129,848	
Gas Volumetric Flow Rate, dscfm	52,375	51,840	52,085	52,100	
Gas Volumetric Flow Rate, scfm	57,654	57,280	57,398	57,444	
Average %CO ₂ by volume, dry basis	5.3	5.2	5.3	5.3	
Average %O ₂ by volume, dry basis	11.9	12.2	12.0	12.0	
Isokinetic Variance	101.9	101.1	102.0	101.7	
Standard Fuel Factor Fd, dscf/mmBtu	8,710.0	8,710.0	8,710.0	8,710.0	
Filterable Particulate Matter (Method 5)					
grams collected	0.00076	0.00035	0.00028	0.00046	
mg/dscm	0.322	0.151	0.119	0.1975	
grains/acf	0.0001	0.0000	0.0000	0.0000	
grains/dscf	0.0001	0.0001	0.0001	0.0001	
lb/hr	0.063	0.029	0.023	0.038	
lb/mmBtu (Standard Fd Factor)	0.0004	0.0002	0.0002	0.0003	
Condensable Particulate Matter (Method 202)					
grams collected	0.00862	0.00667	0.00708	0.00746	
grains/acf	0.0006	0.0005	0.0005	0.0005	
grains/dscf	0.0016	0.0013	0.0013	0.0014	
lb/hr	0.717	0.559	0.588	0.621	
lb/mmBtu (Standard Fd Factor)	0.0046	0.0038	0.0038	0.0041	
Total Particulate Matter (5/202)					
grams collected	0.00938	0.00702	0.00736	0.00792	
grains/acf	0.0007	0.0005	0.0005	0.0006	
grains/dscf	0.0017	0.0014	0.0014	0.0015	
lb/hr	0.780	0.588	0.611	0.660	
lb/mmBtu (Standard Fd Factor)	0.0050	0.0040	0.0040	0.0043	

4.0 CERTIFICATION

MOSTARDI PLATT is pleased to have been of service to Upper Michigan Energy Resources Corporation. If you have any questions regarding this test report, please do not hesitate to contact us at 630-993-2100.

CERTIFICATION

As project manager, I hereby certify that this test report represents a true and accurate summary of emissions test results and the methodologies employed to obtain those results, and the test program was performed in accordance with the methods specified in this test report.

MOSTARDI PLATT

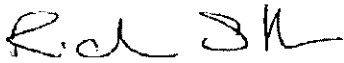

Richard J. Sollars

Program Manager



Scott W. Banach

Quality Assurance

APPENDICES

Appendix A – Plant Operating Data

**F.D. Kuester Generating Station
Compliance Emissions Testing
Summary of Operating Data**

EURICE5				
3/27/2019				
Method 5/202				
<i>Start Time</i>	<i>815</i>	<i>1050</i>	<i>1320</i>	
<i>End Time</i>	<i>1019</i>	<i>1254</i>	<i>1524</i>	
Method 3A, 7E, 10, 25A, and 320				
<i>Start Time</i>	<i>815</i>	<i>1050</i>	<i>1320</i>	
<i>End Time</i>	<i>914</i>	<i>1149</i>	<i>1419</i>	
	Run 1	Run 2	Run 3	Average
Engine (kW)	18,867	18,871	18,878	18,872
Engine natural gas use (pound/hour)	6,618	6,611	6,535	6,588
SCR/Oxidation catalyst inlet temperature) (deg F)	695	695	697	696
Pressure drop across the oxidation catalyst (PSI)	0.12	0.12	0.12	0.12
Urea injection rate to the SCR (gallons/hour)	6.1	6.1	6.1	6.1

EURICE5
SCR/Oxidation Catalyst Inlet Temperature

Start Time	End Time	Value/Average (Deg F)
03-27-2019 08:15 EDT	03-27-2019 08:20 EDT	694
03-27-2019 08:20 EDT	03-27-2019 08:25 EDT	695
03-27-2019 08:25 EDT	03-27-2019 08:30 EDT	696
03-27-2019 08:30 EDT	03-27-2019 08:35 EDT	696
03-27-2019 08:35 EDT	03-27-2019 08:40 EDT	696
03-27-2019 08:40 EDT	03-27-2019 08:45 EDT	696
03-27-2019 08:45 EDT	03-27-2019 08:50 EDT	697
03-27-2019 08:50 EDT	03-27-2019 08:55 EDT	696
03-27-2019 08:55 EDT	03-27-2019 09:00 EDT	696
03-27-2019 09:00 EDT	03-27-2019 09:05 EDT	696
03-27-2019 09:05 EDT	03-27-2019 09:10 EDT	696
03-27-2019 09:10 EDT	03-27-2019 09:15 EDT	696
03-27-2019 09:15 EDT	03-27-2019 09:20 EDT	696
03-27-2019 09:20 EDT	03-27-2019 09:25 EDT	695
03-27-2019 09:25 EDT	03-27-2019 09:30 EDT	694
03-27-2019 09:30 EDT	03-27-2019 09:35 EDT	694
03-27-2019 09:35 EDT	03-27-2019 09:40 EDT	694
03-27-2019 09:40 EDT	03-27-2019 09:45 EDT	694
03-27-2019 09:45 EDT	03-27-2019 09:50 EDT	694
03-27-2019 09:50 EDT	03-27-2019 09:55 EDT	694
03-27-2019 09:55 EDT	03-27-2019 10:00 EDT	695
03-27-2019 10:00 EDT	03-27-2019 10:05 EDT	694
03-27-2019 10:05 EDT	03-27-2019 10:10 EDT	694
03-27-2019 10:10 EDT	03-27-2019 10:15 EDT	694
03-27-2019 10:15 EDT	03-27-2019 10:20 EDT	694
03-27-2019 10:20 EDT	03-27-2019 10:25 EDT	694
03-27-2019 10:25 EDT	03-27-2019 10:30 EDT	694
03-27-2019 10:30 EDT	03-27-2019 10:35 EDT	695
03-27-2019 10:35 EDT	03-27-2019 10:40 EDT	694
03-27-2019 10:40 EDT	03-27-2019 10:45 EDT	694
03-27-2019 10:45 EDT	03-27-2019 10:50 EDT	694
03-27-2019 10:50 EDT	03-27-2019 10:55 EDT	694
03-27-2019 10:55 EDT	03-27-2019 11:00 EDT	694
03-27-2019 11:00 EDT	03-27-2019 11:05 EDT	694
03-27-2019 11:05 EDT	03-27-2019 11:10 EDT	694
03-27-2019 11:10 EDT	03-27-2019 11:15 EDT	694
03-27-2019 11:15 EDT	03-27-2019 11:20 EDT	694
03-27-2019 11:20 EDT	03-27-2019 11:25 EDT	694
03-27-2019 11:25 EDT	03-27-2019 11:30 EDT	695
03-27-2019 11:30 EDT	03-27-2019 11:35 EDT	696
03-27-2019 11:35 EDT	03-27-2019 11:40 EDT	696
03-27-2019 11:40 EDT	03-27-2019 11:45 EDT	696
03-27-2019 11:45 EDT	03-27-2019 11:50 EDT	696
03-27-2019 11:50 EDT	03-27-2019 11:55 EDT	696
03-27-2019 11:55 EDT	03-27-2019 12:00 EDT	696
03-27-2019 12:00 EDT	03-27-2019 12:05 EDT	696

03-27-2019 12:05 EDT	03-27-2019 12:10 EDT	696
03-27-2019 12:10 EDT	03-27-2019 12:15 EDT	695
03-27-2019 12:15 EDT	03-27-2019 12:20 EDT	695
03-27-2019 12:20 EDT	03-27-2019 12:25 EDT	696
03-27-2019 12:25 EDT	03-27-2019 12:30 EDT	696
03-27-2019 12:30 EDT	03-27-2019 12:35 EDT	695
03-27-2019 12:35 EDT	03-27-2019 12:40 EDT	694
03-27-2019 12:40 EDT	03-27-2019 12:45 EDT	694
03-27-2019 12:45 EDT	03-27-2019 12:50 EDT	696
03-27-2019 12:50 EDT	03-27-2019 12:55 EDT	696
03-27-2019 12:55 EDT	03-27-2019 13:00 EDT	696
03-27-2019 13:00 EDT	03-27-2019 13:05 EDT	696
03-27-2019 13:05 EDT	03-27-2019 13:10 EDT	696
03-27-2019 13:10 EDT	03-27-2019 13:15 EDT	696
03-27-2019 13:15 EDT	03-27-2019 13:20 EDT	696
03-27-2019 13:20 EDT	03-27-2019 13:25 EDT	696
03-27-2019 13:25 EDT	03-27-2019 13:30 EDT	697
03-27-2019 13:30 EDT	03-27-2019 13:35 EDT	697
03-27-2019 13:35 EDT	03-27-2019 13:40 EDT	697
03-27-2019 13:40 EDT	03-27-2019 13:45 EDT	697
03-27-2019 13:45 EDT	03-27-2019 13:50 EDT	697
03-27-2019 13:50 EDT	03-27-2019 13:55 EDT	697
03-27-2019 13:55 EDT	03-27-2019 14:00 EDT	697
03-27-2019 14:00 EDT	03-27-2019 14:05 EDT	698
03-27-2019 14:05 EDT	03-27-2019 14:10 EDT	698
03-27-2019 14:10 EDT	03-27-2019 14:15 EDT	698
03-27-2019 14:15 EDT	03-27-2019 14:20 EDT	698
03-27-2019 14:20 EDT	03-27-2019 14:25 EDT	698
03-27-2019 14:25 EDT	03-27-2019 14:30 EDT	698
03-27-2019 14:30 EDT	03-27-2019 14:35 EDT	698
03-27-2019 14:35 EDT	03-27-2019 14:40 EDT	698
03-27-2019 14:40 EDT	03-27-2019 14:45 EDT	698
03-27-2019 14:45 EDT	03-27-2019 14:50 EDT	698
03-27-2019 14:50 EDT	03-27-2019 14:55 EDT	698
03-27-2019 14:55 EDT	03-27-2019 15:00 EDT	697
03-27-2019 15:00 EDT	03-27-2019 15:05 EDT	698
03-27-2019 15:05 EDT	03-27-2019 15:10 EDT	697
03-27-2019 15:10 EDT	03-27-2019 15:15 EDT	696
03-27-2019 15:15 EDT	03-27-2019 15:20 EDT	696
03-27-2019 15:20 EDT	03-27-2019 15:25 EDT	696

Appendix B - Test Section Diagrams

TPM TRAVERSE FOR ROUND DUCTS

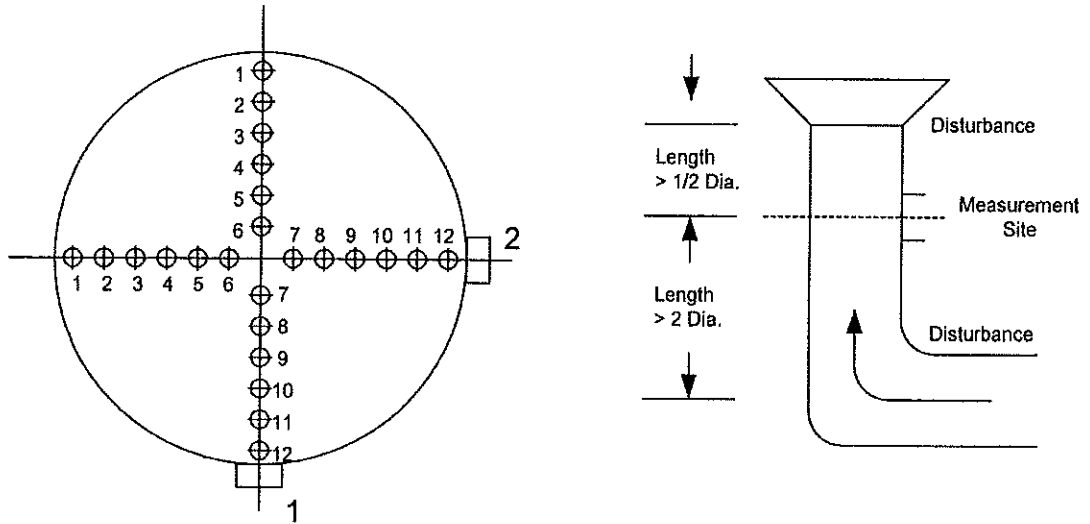

Job: Upper Michigan Energy Resources Corporation
F.D. Kuester Generating Station

Date: 3/27/19

Test Location: EURICE5 Outlet Duct

Duct Diameter: 5.29 Feet

Duct Area: 21.979 Square Feet

No. Points Across Diameter: 24

No. of Ports: 2

Port Length: 8.0 Inches

STRATIFICATION TRAVERSE FOR ROUND DUCTS

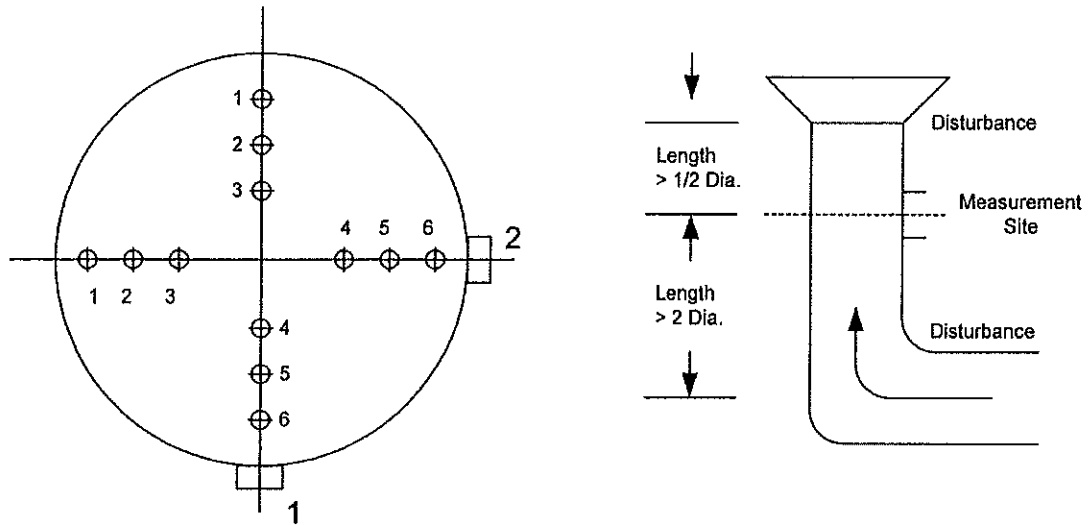

Job: Upper Michigan Energy Resources Corporation
F.D. Kuester Generating Station

Date: 3/27/19

Test Location: EURICE5 Outlet Duct

Duct Diameter: 5.29 Feet

Duct Area: 21.979 Square Feet

No. Points Across Diameter: 6

No. of Ports: 2

Port Length: 8.0 Inches

GASEOUS TRAVERSE FOR ROUND DUCTS

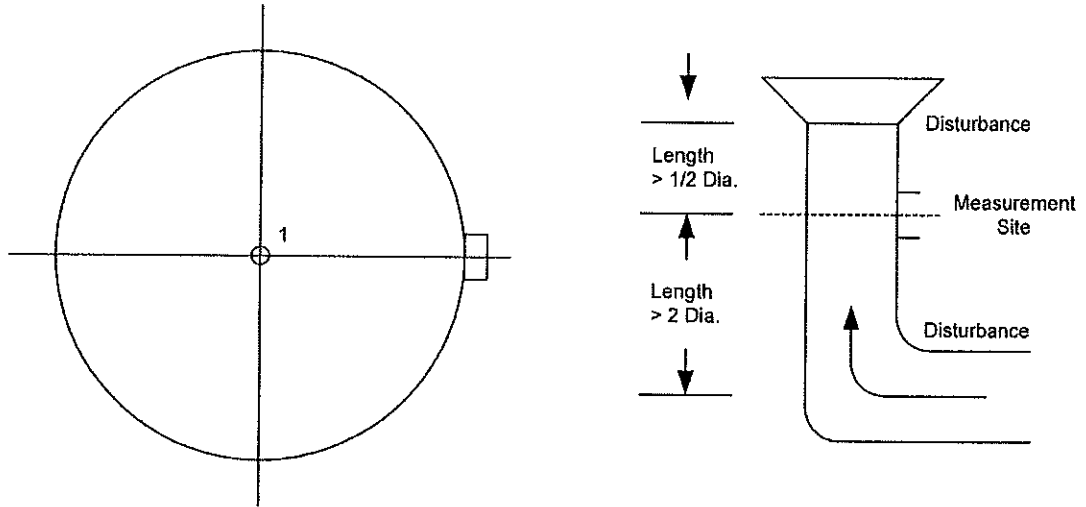

Job: Upper Michigan Energy Resources Corporation
F.D. Kuester Generating Station

Date: 3/27/19

Test Location: EURICE5 Outlet Duct

Duct Diameter: 5.29 Feet

Duct Area: 21.979 Square Feet

No. Points Across Diameter: 1

No. of Ports: 1

Port Length: 8.0 Inches

Appendix C - Sample Train Diagrams

USEPA Method 2 – Type S Pitot Tube Manometer Assembly

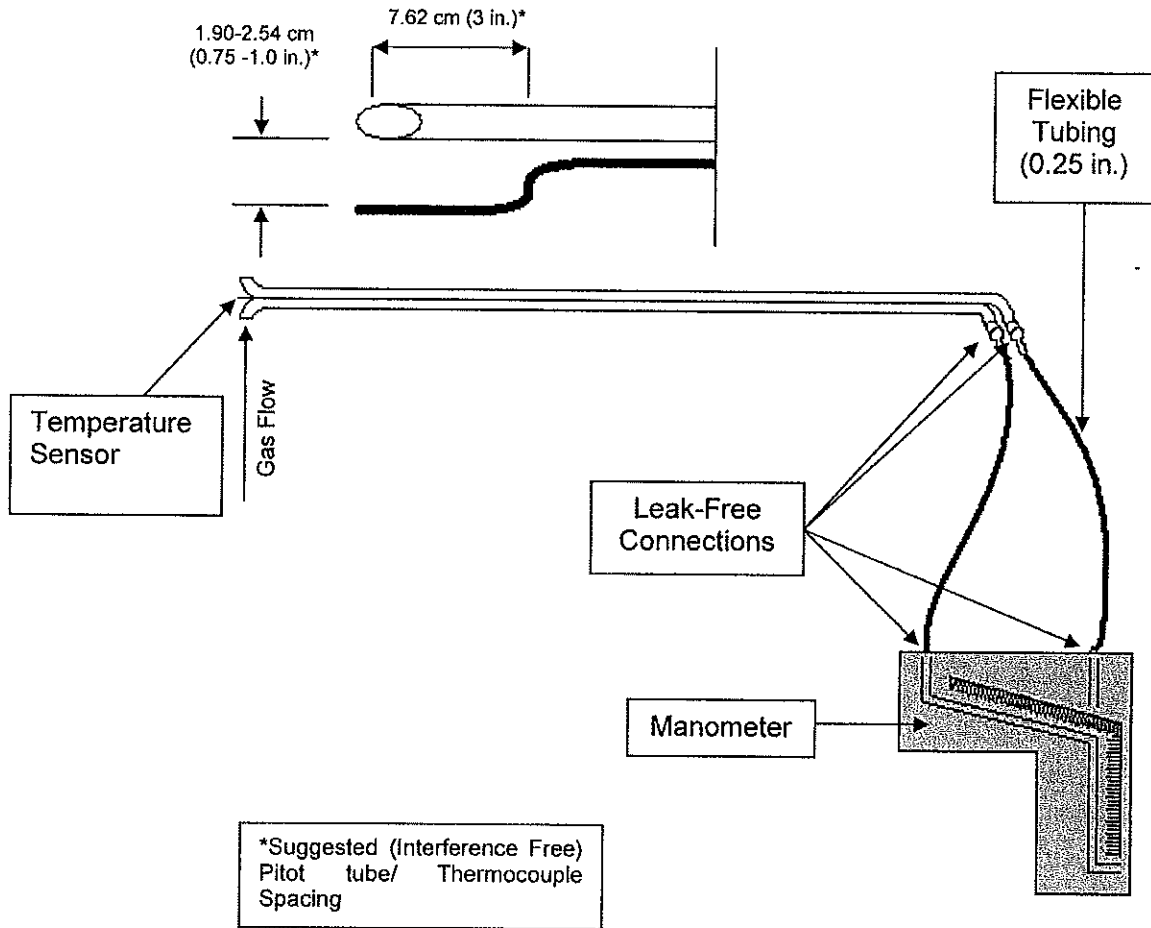

USEPA Method 3A Extractive Gaseous Sampling Diagram

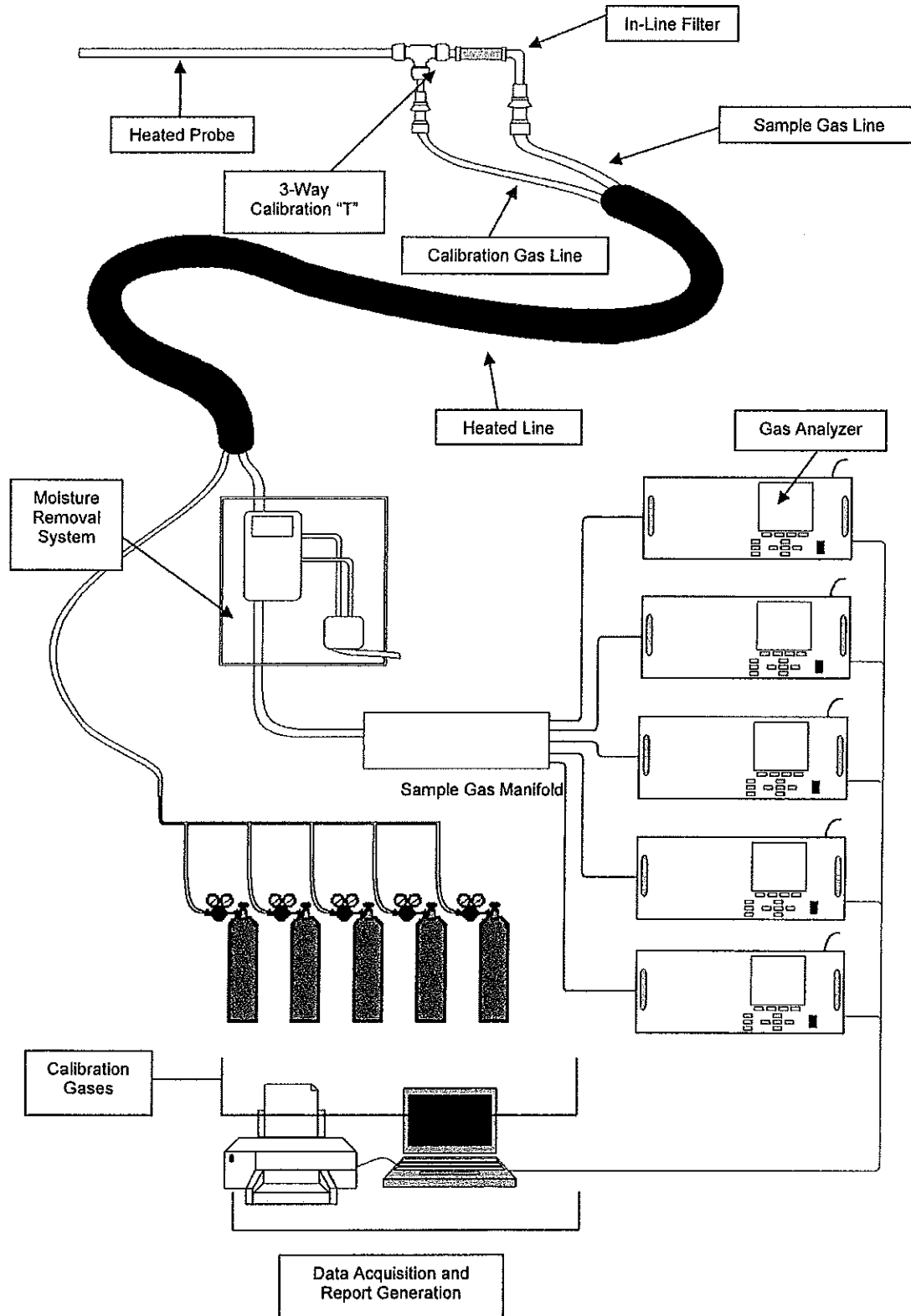

USEPA Method 320 – Vapor Phase Organic and Inorganic Emissions by Extractive Fourier Transform Infrared (FTIR) Spectroscopy Sample Train Diagram

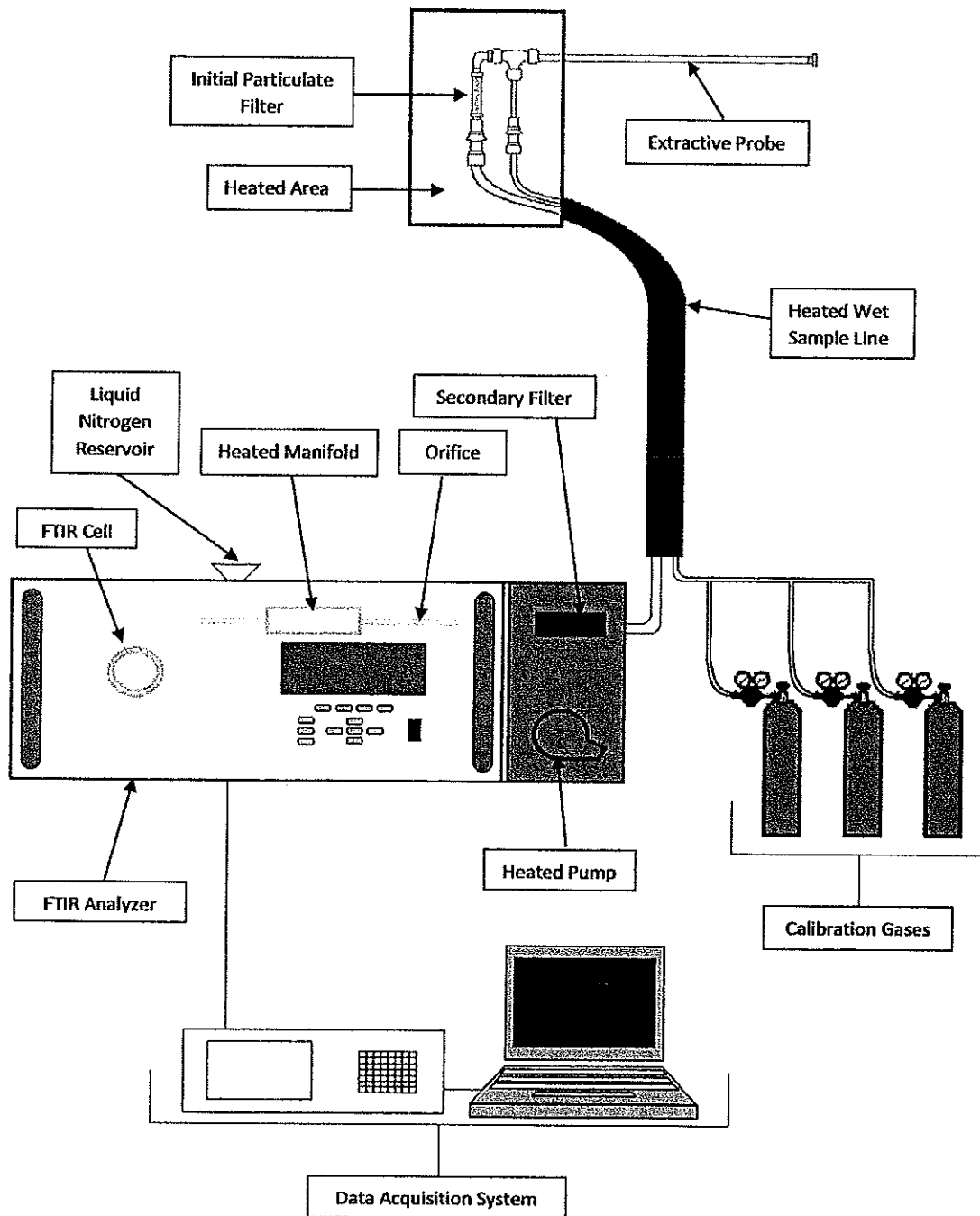

USEPA Method 5/202- Condensable Particulate Matter

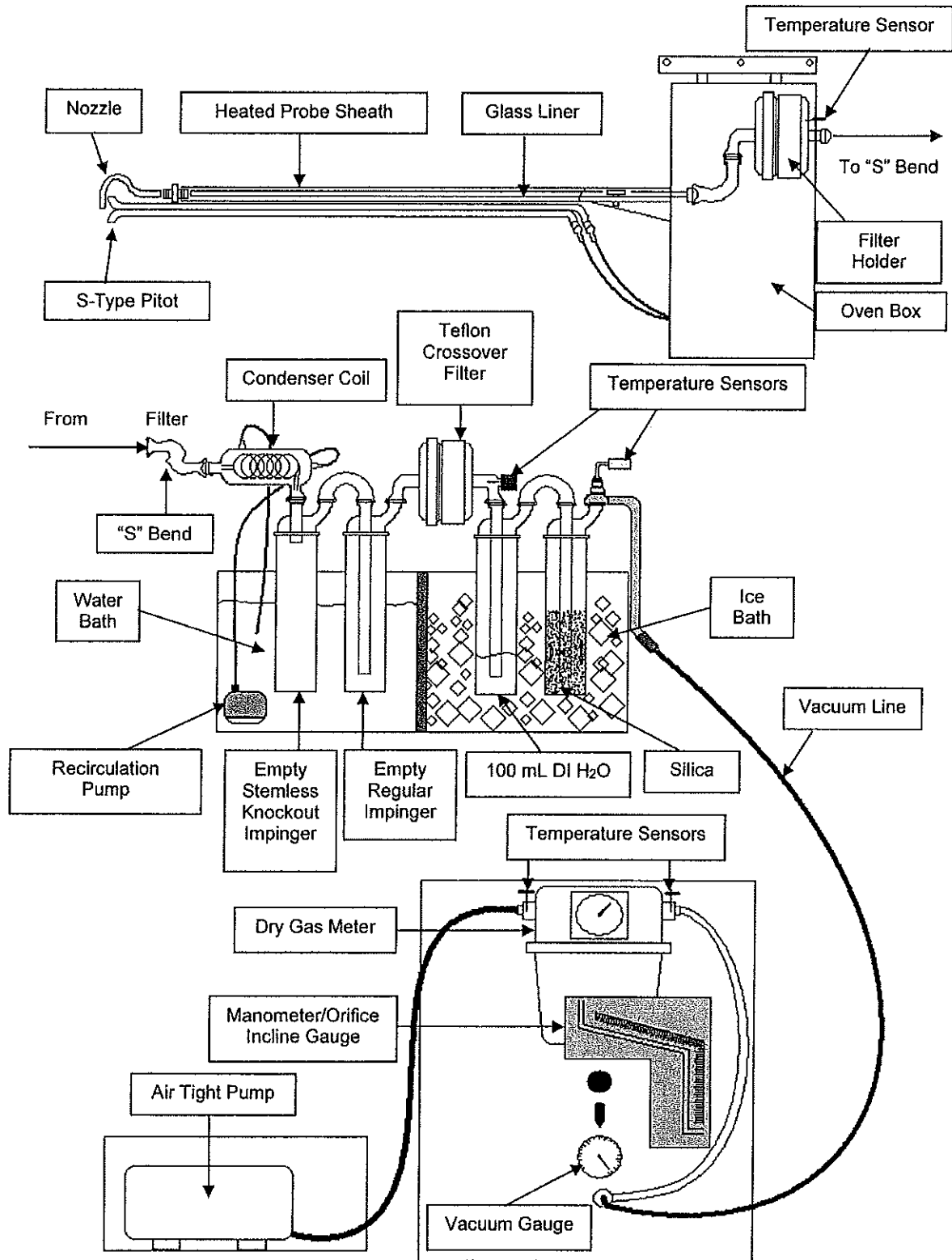

USEPA Method 25A – Total Gaseous Organic Compound Sample Train

