



**RICE Performance and Emission Rate
Test Report**

**Performed for: Upper Michigan Energy Resources
Corporation**

At The: F.D. Kuester Generating Station

MI-ROP-P0797-2020

EURICE5 Outlet Duct

Negaunee, Michigan

October 26, 2023

**Report Submittal Date
December 1, 2023**

© Copyright 2023
All rights reserved in
Mostardi Platt

Project No. M234004E



TABLE OF CONTENTS

1.0 EXECUTIVE SUMMARY	1
2.0 TEST METHODOLOGY	2
Method 1 Traverse Point Determination	2
Method 3A Oxygen (O ₂)/Carbon Dioxide (CO ₂) Determination	3
Method 7E Nitrogen Oxide (NO _x) Determination	3
Method 10 Carbon Monoxide (CO) Determination	3
Method 25A Volatile Organic Compound (VOC) Determination	4
Method 320 Fourier Transform Infrared (FTIR) Detector for Methane and Ethane Determination	4
3.0 TEST RESULT SUMMARY	8
4.0 CERTIFICATION	9
APPENDIX	
Appendix A - Plant Operating Data	11
Appendix B - Test Section Diagrams	13
Appendix C - Sample Train Diagram	16
Appendix D - Calculation Nomenclature and Formulas	18
Appendix E - Reference Method Test Data (Computerized Sheets) and Laboratory Data	27
Appendix F - Calibration Data	38
Appendix G - FTIR QA/QC	43
Appendix H - Gas Cylinder Certifications	47



1.0 EXECUTIVE SUMMARY

MOSTARDI PLATT conducted a RICE performance and emission rate test program for Upper Michigan Energy Resources Corporation (UMERC) on October 26, 2023 at F.D. Kuester Generating Station on the Reciprocating Internal Combustion Engine 5 (EURICE5) Outlet Duct in Negaunee, Michigan. The purpose of the test program was to meet the ongoing compliance demonstration requirements for emission rates in accordance with Renewable Operating Permit MI-ROP-P0797 and 40 CFR Part 60 Subpart JJJJ. This report summarizes the results of the test program and test methods used.

The test location, test date, and test parameters are summarized below.

Test Location	Test Date	Test Parameters
EURICE5 Outlet Duct	October 26, 2023	Nitrogen Oxides (NO _x), Carbon Monoxide (CO), Carbon Dioxide (CO ₂), Oxygen (O ₂), Volatile Organic Compounds (VOCs), and Moisture

F.D. Kuester Generating Station electric generation facility includes seven (7) Wärtsilä W18V50SG natural gas-fired, four stroke, lean burn, spark ignition reciprocating internal combustion engines (RICE) coupled to 19,260 kW electric generators, a 1,000-kW natural gas-fired emergency generator, and one natural gas-fired natural gas conditioning heater. The RICE electric generating unit engines utilize pipeline quality natural gas and are equipped with selective catalytic reduction (SCR) for nitrogen oxides (NO_x) control and oxidation catalyst systems for carbon monoxide (CO), volatile organic compound (VOC), and organic hazardous air pollutant (HAP) control. Each RICE electric generating unit exhausts into a common stack.

Selected results of the test program are summarized below on a ppmvd @ 15% O₂ basis. A complete summary of emission test results follows the narrative portion of this report. The emissions of the VOC as ppmv were calculated to be less than the method detection for each of the runs. The method detection was used for the emission rate based on the standard deviation of the calibrations of 2.5 ppmv.

TEST RESULTS				
Test Location	Test Date	Test Parameter	Emission Limit	Emission Rate
EURICE5 Outlet Duct	10/26/2023	NO _x	82 ppmvd @ 15% O ₂	2.9 ppmvd @ 15% O ₂
			3.0 lb/hr	1.7 lb/hr
		CO	270 ppmvd @ 15% O ₂	7.9 ppmvd @ 15% O ₂
			5.5 lb/hr	2.8 lb/hr
		VOC (as C ₃ H ₈)	60 ppmvd @ 15% O ₂	<1.8 ppmvd @ 15% O ₂
			5.5 lb/hr	<1.0 lb hr

Operating Data as provided by the plant is included in Appendix A.

The identifications of the individuals associated with the test program are summarized below.

TEST PERSONNEL INFORMATION		
Location	Address	Contact
Test Coordinator	WEC Energy Group, Inc 231 W. Michigan Street Milwaukee, Wisconsin 53203	Mr. Justin Kowalski Senior Environmental Consultant 414-221-2265 justin.kowalski@wecenergygroup.com
Test Facility	Upper Michigan Energy Resources Corporation F.D. Kuester Generating Station 80 Eagle Mills Road Negaunee, MI 49866	
Testing Company Representative	Mostardi Platt 888 Industrial Drive Elmhurst, Illinois 60126	Mr. Jeffery Gross Project Manager (630) 993-2100 (phone) jgross@mp-mail.com

The test crew consisted of J. Dockins, J. Jimenez, and J. Gross of Mostardi Platt.

2.0 TEST METHODOLOGY

Emission testing was conducted following the methods specified in Code of Federal Regulations, Title 40, Part 60, Appendix A (40CFR60), 40CFR51, and 40CFR63. Schematics of the test section diagrams and sampling trains used are included in Appendix B and C, respectively. Calculation examples and nomenclature are included in Appendix D. Copies of analyzer print-outs for each test run are included in Appendix E.

The following methodologies were used during the test program:

Method 1 Traverse Point Determination

Test measurement points were selected in accordance with Method 1. The characteristics of the measurement location are summarized below.

TEST POINT INFORMATION						
Location	Diameter (Feet)	Area (Square Feet)	Upstream Distance (Inches)	Downstream Distance (Inches)	Test Parameter	Number of Sampling Points
EURICE5 Outlet Duct	5.29	21.98	>0.5	>2.0	NO _x , CO, VOC, O ₂ , CO ₂	12 (strat), 1

Method 3A Oxygen (O₂)/Carbon Dioxide (CO₂) Determination

Flue gas O₂ was determined in accordance with Method 3A. A Servomex analyzer was used to determine stack gas oxygen content connected to the outlet of the FTIR analyzer.

Flue gas carbon dioxide concentrations and emission rates were determined in accordance with Method 3A. An MKS MultiGas 2030 FTIR spectrometer was used to determine the CO₂ concentrations, in the manner specified in the Method. Nitrogen content was determined from the difference of CO₂ and O₂.

Stack gas was delivered to the analyzer via a Teflon® sampling line, heated to a minimum temperature of 375°F. The entire system was calibrated in accordance with the Method, using certified calibration gases introduced at the probe, before and after each test run.

All of the equipment used was calibrated in accordance with the specifications of the Method and calibration data are included in Appendix F. Copies of the gas cylinder certifications are included in Appendix H.

Method 7E Nitrogen Oxide (NO_x) Determination

Flue gas nitrogen oxide concentrations and emission rates were determined in accordance with Method 7E. An MKS MultiGas 2030 FTIR spectrometer was used to determine nitrogen oxide concentrations, in the manner specified in the Method.

Stack gas was delivered to the analyzer via a Teflon® sampling line, heated to a minimum temperature of 375°F. The entire system was calibrated in accordance with the Method, using certified calibration gases introduced at the probe, before and after each test run.

A list of calibration gases used and the results of all calibration and other required quality assurance checks can be found in Appendix F. Copies of calibration gas certifications can be found in Appendix H.

Method 10 Carbon Monoxide (CO) Determination

Flue gas nitrogen oxide concentrations and emission rates were determined in accordance with Method 10. An MKS MultiGas 2030 FTIR spectrometer was used to determine carbon monoxide concentrations, in the manner specified in the Method.

Stack gas was delivered to the analyzer via a Teflon® sampling line, heated to a minimum temperature of 375°F. The entire system was calibrated in accordance with the Method, using certified calibration gases introduced at the probe, before and after each test run.

A list of calibration gases used and the results of all calibration and other required quality assurance checks can be found in Appendix F. Copies of calibration gas certifications can be found in Appendix H.

Method 25A Volatile Organic Compound (VOC) Determination

Total hydrocarbon (THC) concentrations and emission rates were determined in accordance with Method 25A. A Thermo 51i analyzer was used to determine THC concentrations. Stack gas was delivered to the system via a Teflon® sampling line, heated to a minimum temperature of 375°F.

Methane and ethane concentrations were determined in accordance with Method 320 and then subtracted from the THC concentrations in order to comply with non-methane, non-ethane hydrocarbon criteria as specified in the permit. The methane concentration was also corrected for a response factor for the Thermo 51i analyzer. These results can be found in Appendix G along with the calibration data.

The system was calibrated before and after each test run using certified calibration gases of propane for the THC determination. Copies of gas certifications are presented in Appendix H.

Method 320 Fourier Transform Infrared (FTIR) Detector for Methane and Ethane Determination

The Method 320 sampling and measurement system meets the requirements of US EPA Reference Method 320, "Vapor Phase Organic and Inorganic Emissions by Extractive FTIR," 40CFR63, Appendix A. This method applies to the measurement of combustion gas concentrations. With this method, gas samples are extracted from the sample locations through heated Teflon sample lines to the analyzer.

FTIR technology works on the principle that most gases absorb infrared light. This is true for all compounds with the exception of homonuclear diatomic molecules and noble gases such as: N₂, O₂, H₂, He, Ne, and Ar. Vibrations, stretches, bends, and rotations within the bonds of a molecule determine the infrared absorption distinctiveness. The absorption creates a "fingerprint" which is unique to each given compound.

The quantity of infrared light absorbed is proportional to the gas concentration. Most compounds have absorbencies at different infrared frequencies, allowing the simultaneous analysis of multiple compounds at one time. The FTIR software compares each sample spectrum to a user-selected list of calibration references and performs a classical least squares analysis to determine concentration data on a wet volume basis and the spectral residuals for each analyte (the error associated with each measurement). FTIR data was collected using an MKS MultiGas 2030 FTIR spectrometer. The FTIR was equipped with a temperature-controlled, 5.11-meter multi-pass gas cell maintained at 191°C. Gas flows and sampling system pressures were monitored using a rotameter and pressure transducer.

All data was collected at 0.5 cm⁻¹ resolution. Each spectrum was derived from the coaddition of 62 scans, with a new data point generated approximately every one minute. Analyzer data for each run is present in Appendix E.

SAMPLING SYSTEM PARAMETERS				
MKS Serial #	Sampling Line	Probe Assembly	Particulate Filter Media	Operating Temperatures
111171031	100' 3/8" dia., heated Teflon	Heated 8', 3/8" dia. SS	0.01µ heated borosilicate glass fiber	191°C

QA/QC procedures followed US EPA Method 320. See below for QA/QC procedure details and list of calibration gas standards. All calibration gases were introduced to the analyzer and the sampling system using an instrument grade stainless steel rotameter. All QA/QC procedures were within the acceptance criteria allowance of the applicable EPA methodology. See Appendix G for FTIR QA/QC Data and instrument linearity validations.

FTIR QA/QC PROCEDURES						
QA/QC Specification	Purpose	Calibration Gas Analyte	Delivery	Frequency	Acceptance Criteria	Result
M320: Zero	Verify that the FTIR is free of contaminants & zero the FTIR	Nitrogen (zero)	Direct to FTIR	pre/post test	< MDL or Noise	Pass
M320: Calibration Transfer Standard (CTS) Direct	Verify FTIR linearity, confirm optical path length	Ethylene	Direct to FTIR	pretest	+/- 5% cert. value	Pass
M320: CTS Response	Verify system linearity, recovery, response time	Ethylene	Sampling System	Daily, pre/post test	+/- 5% of Direct Measurement	Pass
M320: Zero Response	Verify sampling system has no bias for analytes of interest	Nitrous Oxide with nitrogen balance	Sampling System	pretest	Bias correct data	Pass
M320: Analyte Spike	Verify system ability to deliver and quantify analyte of interest in the presence of effluent gases	Formaldehyde, SF6	Dynamic Addition to Sampling System, 1:10 effluent	Throughout testing – daily	+/- 30% theoretical recovery	Pass

Note: The determined concentrations from direct analyses were used in all system/spike recovery calculations.

The M320 Analyte Direct calibration did not meet the acceptance criteria prior to testing. This occurs due to cylinder stability over time which impacts the tag values as well as corrosion in the regulators which cause a loss of formaldehyde. Consequently, the determined concentration from the direct analysis was used in all system/spike recovery calculations. Performing all of the other health /QA checks of the FTIR showed the instrument working as well as reading the formaldehyde direct properly which validates the data and does not impact the compliance determination.

CALIBRATION GAS STANDARDS				
Components	Concentration (ppm)	Vendor	Cylinder #	Standard Type
Ethylene	99.97	Airgas	EB0153619	Certified Standard-Spec +/- 2%
Formaldehyde/SF6	8.705/5.075	Airgas	EB0146284	Certified Standard +/- 2% (Acetaldehyde/Methanol) Certified Standard +/- 5% (SF ₆)
Nitrogen	Zero Gas	Airgas	N/A	UHP Grade

Analyte Spiking

Formaldehyde spiking was performed prior to testing to verify the ability of the sampling system to quantitatively deliver a sample containing formaldehyde from the base of the probe to the FTIR. Analyte spiking assures the ability of the FTIR sampling system to recover volatile organics in the presence of effluent gas.

As part of the spiking procedure, samples were measured to determine native formaldehyde concentration to be used in the spike recovery calculations. The analyte spiking gases contained a low concentration of sulfur hexafluoride (SF₆). The determined SF₆ concentration in the spiked sample was used to calculate the dilution factor of the spike and thus used to calculate the concentration of the spiked formaldehyde. The spike target dilution ratio was 1:10 or less.

The following equation illustrates the percent recovery calculation.

$$DF = \frac{SF6(spik)}{SF6(direct)} \quad (\text{Sec. 9.2.3 (3) USEPA Method 320})$$

$$CS = DF * Spike(dir) + Unspike(1 - DF) \quad (\text{Sec. 9.2.3 (4) USEPA Method 320})$$

- DF = Dilution factor of the spike gas
- SF_{6(dir)} = SF₆ concentration measured directly in undiluted spike gas
- SF_{6(spik)} = Diluted SF₆ concentration measured in a spiked sample
- Spike_{dir} = Concentration of the analyte in the spike standard measure by the FTIR directly
- CS = Expected concentration of the spiked samples
- Unspike = Native concentration of analytes in unspiked samples

Post Collection Data Validation

As part of the data validation procedure, reference spectra are manually fit to that of the sample spectra and a concentration is determined. The reference spectra are scaled to match the peak amplitude of the sample, providing a scaling factor. The scaling factor multiplied by the reference spectra concentration is used to determine the concentration value for the sample spectra. Sample pressure and temperature corrections are then applied to compute the final sample concentration. The manually calculated results are then compared with the software-generated results. The data is then validated if the two concentrations are within ± 20% agreement. In some cases, the percent difference between the two analyses is relatively large, but the absolute concentration difference is minimal. If this is not determined to be the case, then the spectra are reviewed for possible spectral interferences or any other possible causes leading to incorrectly quantified data. See Appendix G FTIR QAQC for manual subtractions.

Detection Limit

The detection limit of each analyte was calculated following Annex A2 of ASTM D6348-12 procedure using spectra that contained similar amounts of moisture and carbon dioxide.

Analyte	Detection Limit (ppmv wet)	Detection Limit (%v)
Methane	1.0	-
Ethane	0.5	-
Moisture	-	0.1

The spectral residuals for each compound is calculated using the classical least squares analysis. When the residual error exceeds the measured concentration, the compound is considered a non-detect, allowing the residual to verify the detection limit. The spectral residual also permits the analyst to determine if there are possible interferences in the sample matrix.

QA/QC data are found in Appendix G. Copies of gas cylinder certifications are found in Appendix H. All concentration data were recorded on a wet, volume basis. The sample and data collection followed the procedures outlined in Method 320.

3.0 TEST RESULT SUMMARY

Upper Michigan Energy Resources Corporation F. D. Kuester Generating Facility EURICE 5 Outlet Duct October 26, 2023 Reference Method Test Data																		
Test No.	Start Time	End Time	NOx ppmvw		VOC ppmvw as C ₂ H ₆ *	CO ppmvw	Moisture, %	NOx ppmvd @ 15% O ₂		VOC ppmvd as C ₂ H ₆ @ 15% O ₂	CO ppmvd @ 15% O ₂	O ₂ % (dry)	Flow, SCFM	Flow, SCFH	NOx lb/hr	VOC lb/hr	CO lb/hr	
1	7:40	8:49	3.6	≤	2.5	11.2	9.95	2.6	≤	1.8	7.9	11.6	55,980	3,358,800	1.5	≤	1.0	2.7
2	9:02	10:01	4.3	≤	2.5	11.3	9.96	3.1	≤	1.8	8.0	11.6	57,875	3,460,500	1.8	≤	1.0	2.8
3	10:17	11:16	4.3	≤	2.5	11.2	10.03	3.0	≤	1.8	7.9	11.6	57,963	3,477,780	1.8	≤	1.0	2.8
Average			4.1	≤	2.5	11.2	9.98	2.9	≤	1.8	7.9	11.6	57,206	3,432,360	1.7	≤	1.0	2.8

* Non detect - method detection of 2.5 ppmv used in the calculations

4.0 CERTIFICATION

MOSTARDI PLATT is pleased to have been of service to Upper Michigan Energy Resources Corporation. If you have any questions regarding this test report, please do not hesitate to contact us at 630-993-2100.

CERTIFICATION

As project manager, I hereby certify that this test report represents a true and accurate summary of emissions test results and the methodologies employed to obtain those results, and the test program was performed in accordance with the methods specified in this test report.

MOSTARDI PLATT



Jeffery M. Gross

Program Manager



Scott W. Banach

Quality Assurance

APPENDICES

Appendix A – Plant Operating Data

F.D. Kuester Generating Station
Performance Emissions Testing
40 CFR Part 60 Subpart JJJJ & 63 Subpart ZZZZ (MACT)
October 26, 2023

EURICE5				
10/26/2023				
<i>Start Time</i>	740	902	1017	
<i>End Time</i>	849	1001	1116	
	Run 1	Run 2	Run 3	Average
Engine (kW)	18,908	18,913	18,923	18,915
Engine natural gas use (pound/hour)	6,757	6,757	6,752	6,755
SCR/Oxidation catalyst inlet temperature) (deg F)	702	702	703	702
Pressure drop across the oxidation catalyst (PSI)	0.14	0.14	0.14	0.14
Urea injection rate to the SCR (gallons/hour)	4.2	4.1	4.1	4.1

Appendix B - Test Section Diagrams

STRATIFICATION TRAVERSE FOR ROUND DUCTS

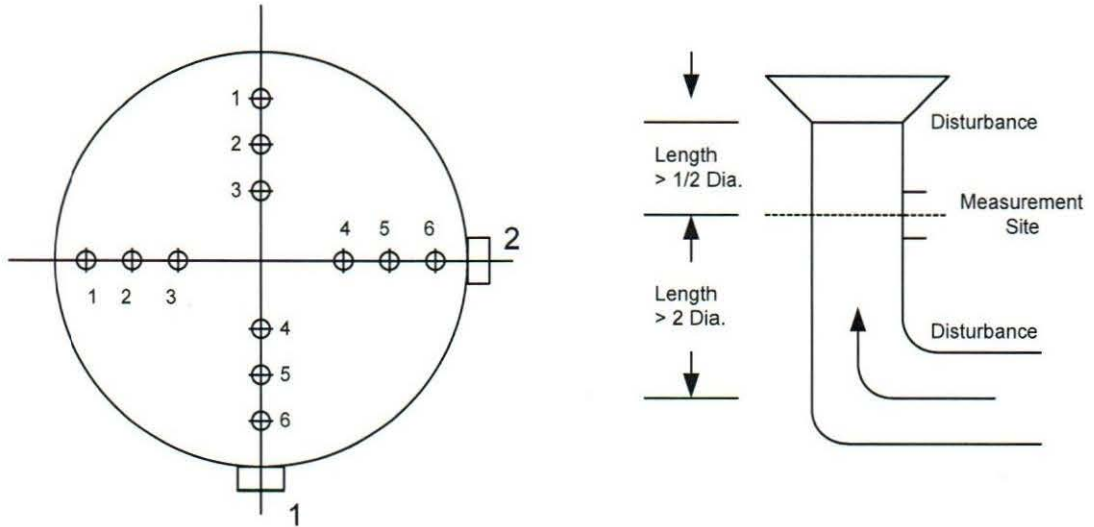

Job: Upper Michigan Energy Resources Corporation
F.D. Kuester Generating Station

Date: October 26, 2023

Test Location: EURICE5 Outlet Duct

Duct Diameter: 5.29 Feet

Duct Area: 21.98 Square Feet

No. Points Across Diameter: 6

No. of Ports: 2

Port Length: 8.0 Inches

GASEOUS TRAVERSE FOR ROUND DUCTS

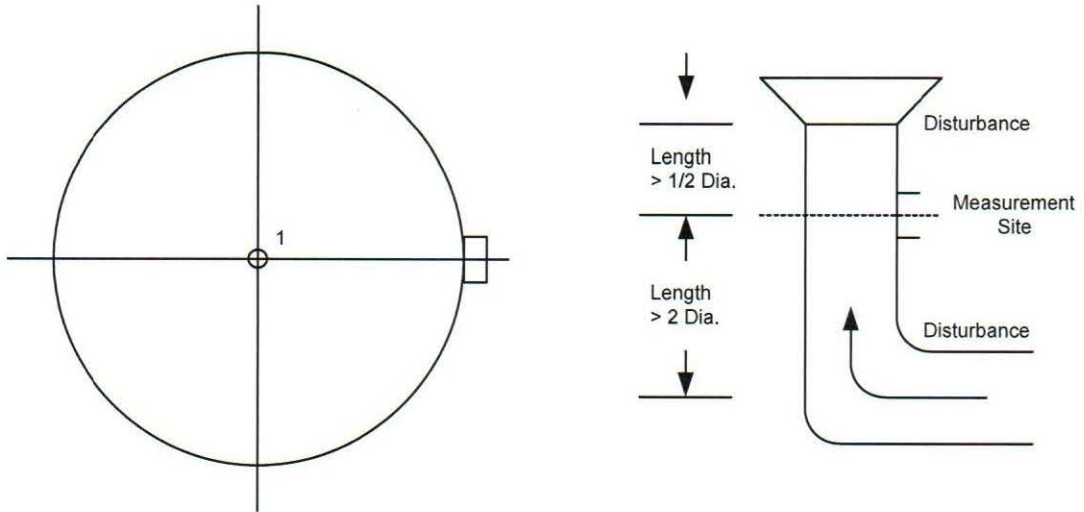

Job: Upper Michigan Energy Resources Corporation
F.D. Kuester Generating Station

Date: October 26, 2023

Test Location: EURICE 5 Outlet Duct

Duct Diameter: 5.29 Feet

Duct Area: 21.98 Square Feet

No. Points Across Diameter: 1

No. of Ports: 1

Port Length: 8.0 Inches

Appendix C - Sample Train Diagram

USEPA Methods 3A, 7E, 10, 25A, and 320 – Sample Train Diagram

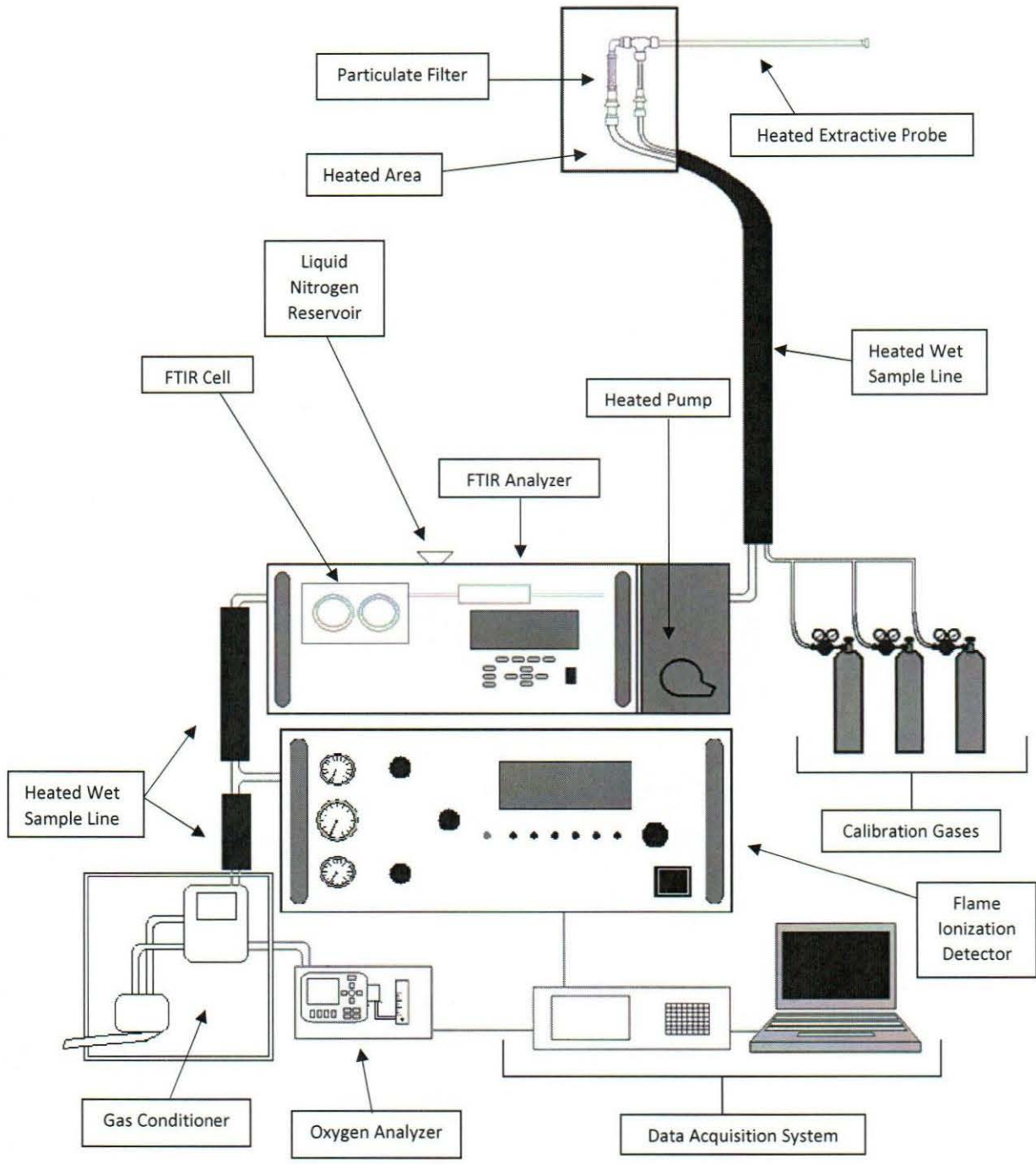

Appendix D -Calculation Nomenclature and Formulas